

BOONE COUNTY BUILDING DEPARTMENT
2950 WASHINGTON STREET, # 312
BURLINGTON KY, 41005
859-334—2218

GENERAL REQUIREMENTS FOR RESIDENTIAL BASEMENT FINISH 2015 KENTUCKY RESIDENTIAL CODE

Address of Project _____ Application # _____
Applicant's Name (printed) _____ Signature _____

This document, when signed and initialed, will become part of the application for permit. The requirements on this document will take precedence over any discrepancies within the documents. All items shall be checked, and the signature of the Applicant above indicates agreement with all of the stated requirements.

The following items are supplemental construction notes provided by, the Boone County Building Department Based on the minimum requirements of the 2015 Kentucky Residential Code Section 324.

- Finished portions of the basement that are not specifically designated as a "bedroom" shall not be used for sleeping purposes. Sleeping shall not occur in other finished basement spaces at any time.
- Smoke detectors shall be provided in each bedroom, outside each sleeping area in the vicinity of bedrooms, and on each level of the existing residence, including the basement. These smoke detectors are permitted to be battery-operated unless located in the new areas of construction. Smoke detectors located in areas changed by this permit shall be hard-wired with battery back-up and, if applicable, interconnected to each other. Code also allows interconnectedness shows for wireless technologies.
- Carbon monoxide alarms shall be installed per KRC315.3
- All bathrooms without an operable window shall be provided with a minimum 50 cfm exhaust fan vented directly to the exterior of the residence.
- The ceiling height in the finished habitable portions of the basement shall be minimum 6'-8" with not less 6'-4" below any ceiling projections.
- Firestops shall be provided in the air space between the new interior stud wall and the existing concrete foundation wall at a maximum of 10 ft. horizontally and at the top of the stud wall. Fire blocking is inspected at the framing stage before you drywall.
- All lumber which will come in direct contact with concrete or masonry to be pressure-treated for exterior use.
- All enclosed, accessible spaces below the basement stair shall have its walls and ceiling finished with minimum ½" gypsum board (drywall).
- Where existing dwellings have an attached garage or a fuel-fired appliance (s) carbon monoxide alarms shall be provided and installed outside of each separate sleeping area in the immediate vicinity of the bedrooms.
- Bedrooms in basement shall have an emergency escape and rescue openings. Grade floor openings shall have a minimum net clear opening of 5 square feet. Emergence escape and rescue openings shall have a sill height of not more than 44 inches, measured from the finished floor to the bottom of the clear opening.
- Illumination shall be provided for the full length stair and its associated landings.
- Ventilation is required when enclosing furnace rooms and water heaters. Please specify what type of furnace or water heater you are enclosing (i.e. high efficiency, gas, electric, etc).
- HVAC alterations: If you are adding ductwork or making any other alterations to the HVAC system, a separate building permit is required from this office.

DISCLAIMER:

This worksheet highlights specific sections of the 2015 Kentucky Residential Code in order to facilitate plan submission. It is not intended to be a complete summary of that document.

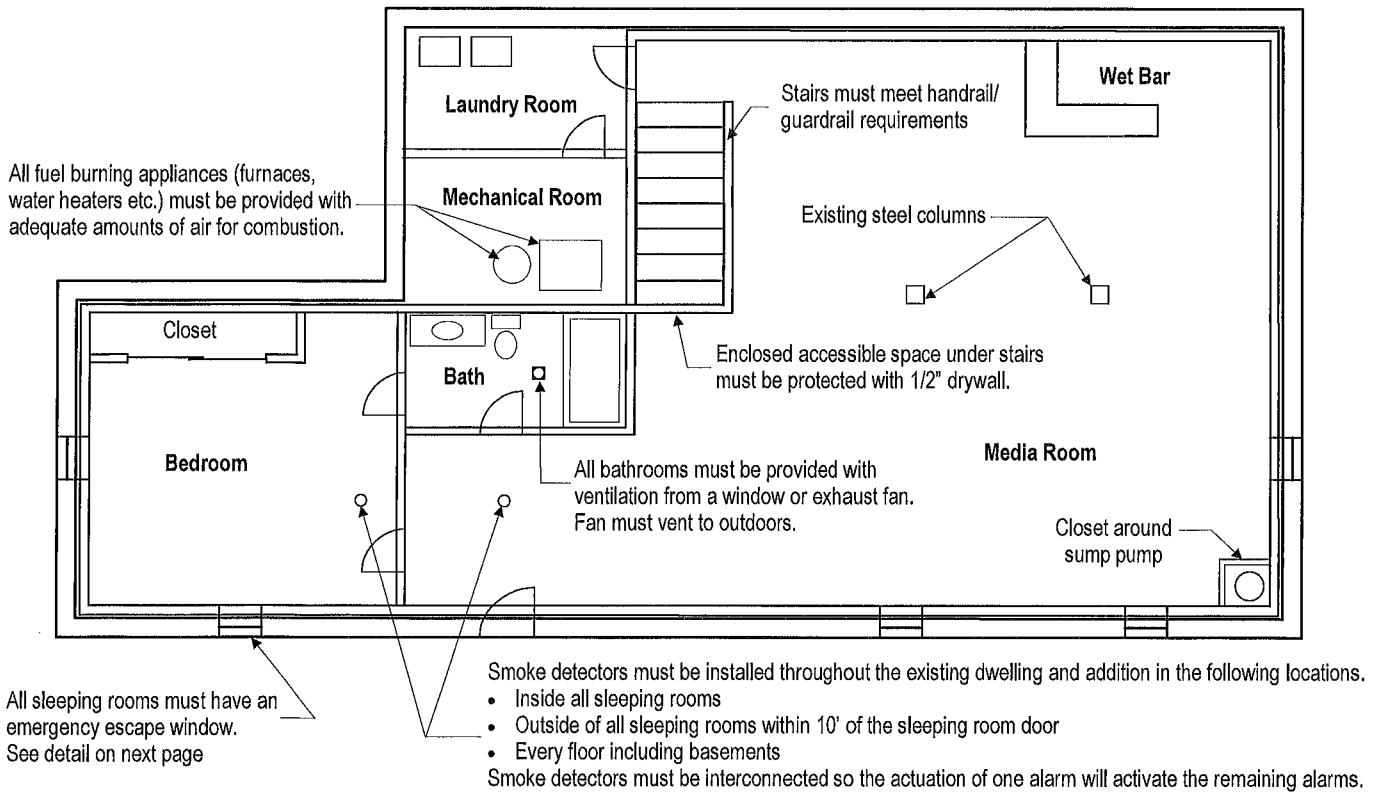

FLOOR PLAN FOR BASEMENT FINISH

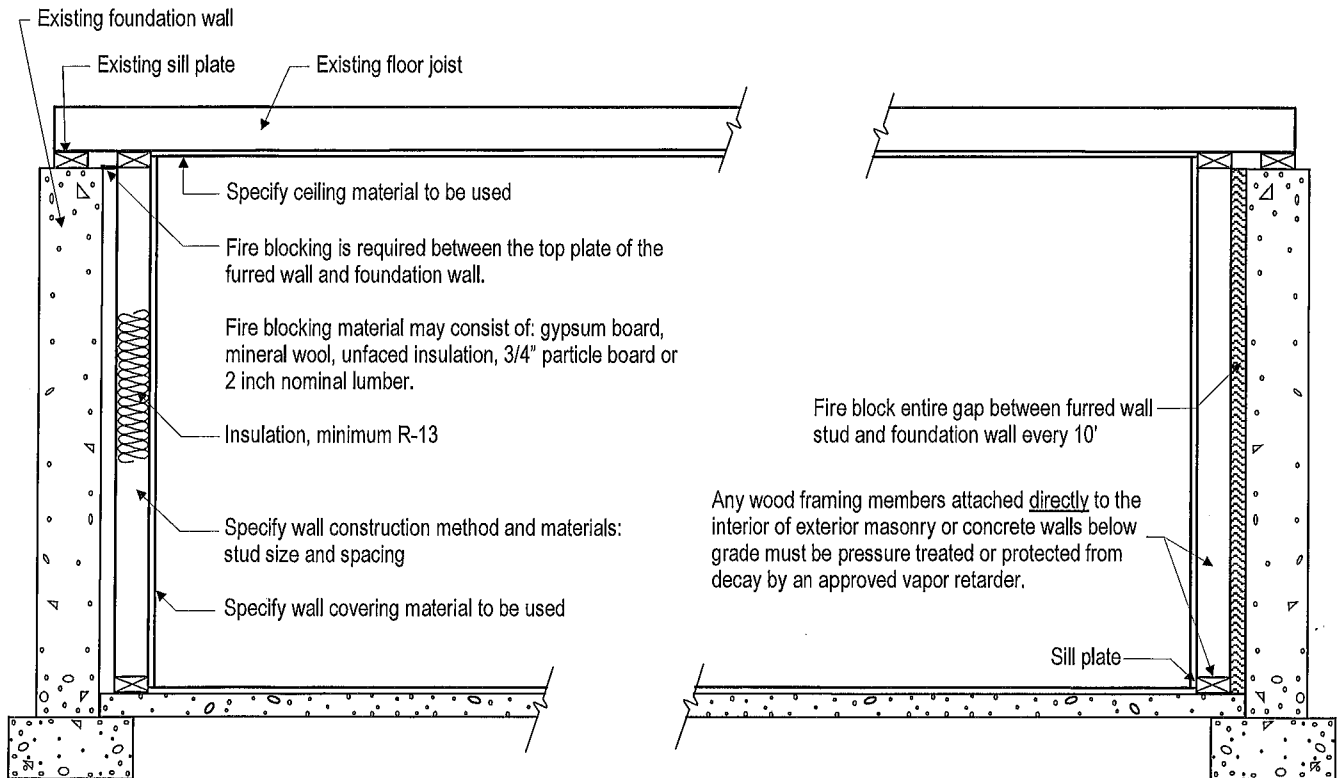

TYPICAL WALL SECTION

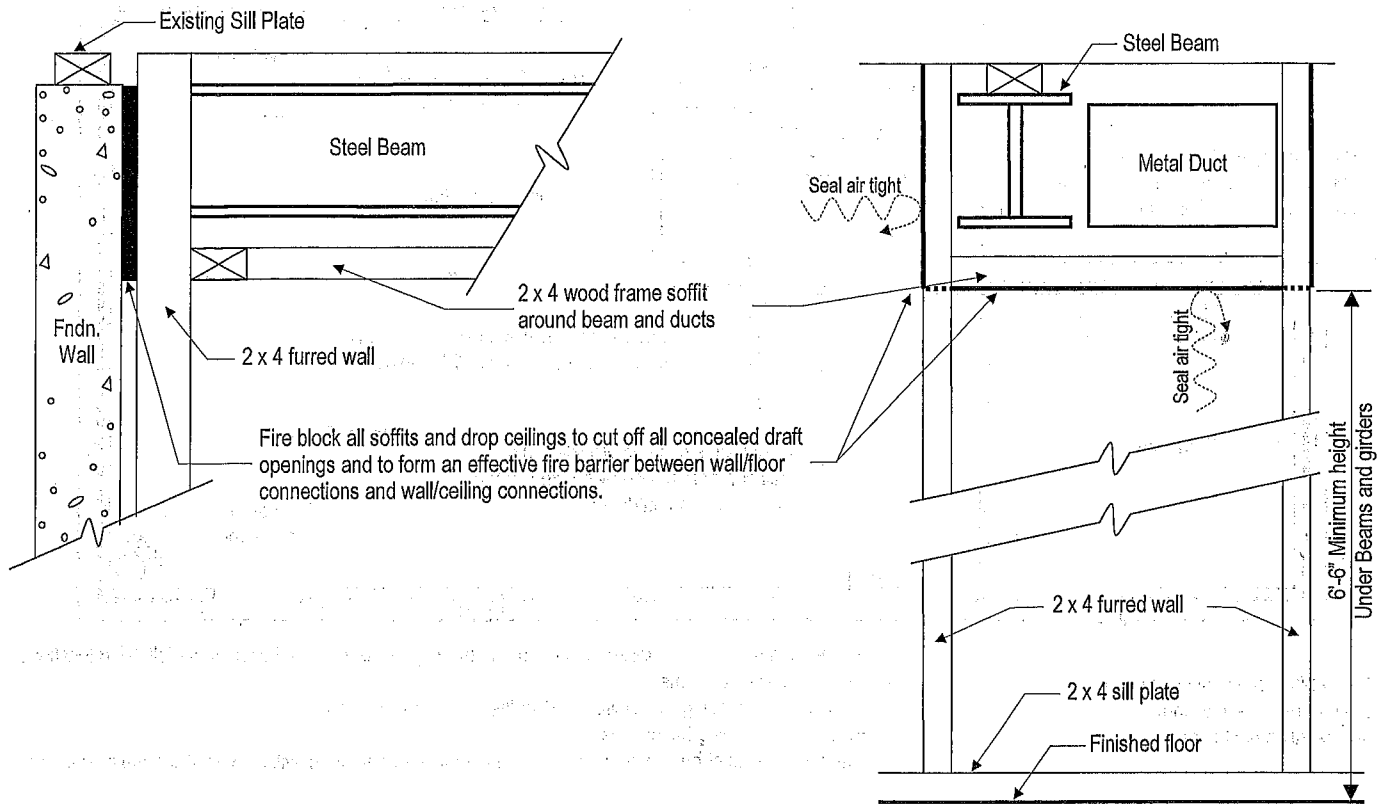

SOFFIT FIRESTOPPING DETAIL

Bars, grilles, covers, screens or similar devices are permitted to be placed over emergency escape openings or window wells provided they meet the minimum net clear opening requirements and such devices are releasable or removable from the inside without the use of a key, tool, special knowledge or force greater than that which is required for normal operation of the escape and rescue opening.

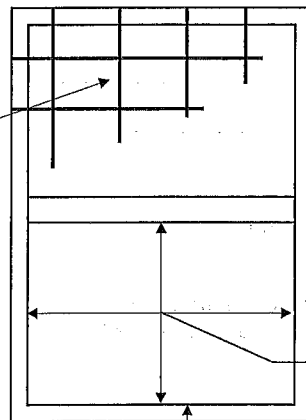

The emergency escape window must have a minimum opening of 5 square feet. The opening must be at least 20" wide and the height of the opening must be at least 24".

44" Max. sill height for egress (bedroom) windows measured from floor to top of sill.

Emergency escape and rescue openings shall be operational from the inside of the room without the use of keys, tools or special knowledge.

EMERGENCY ESCAPE WINDOW DETAIL

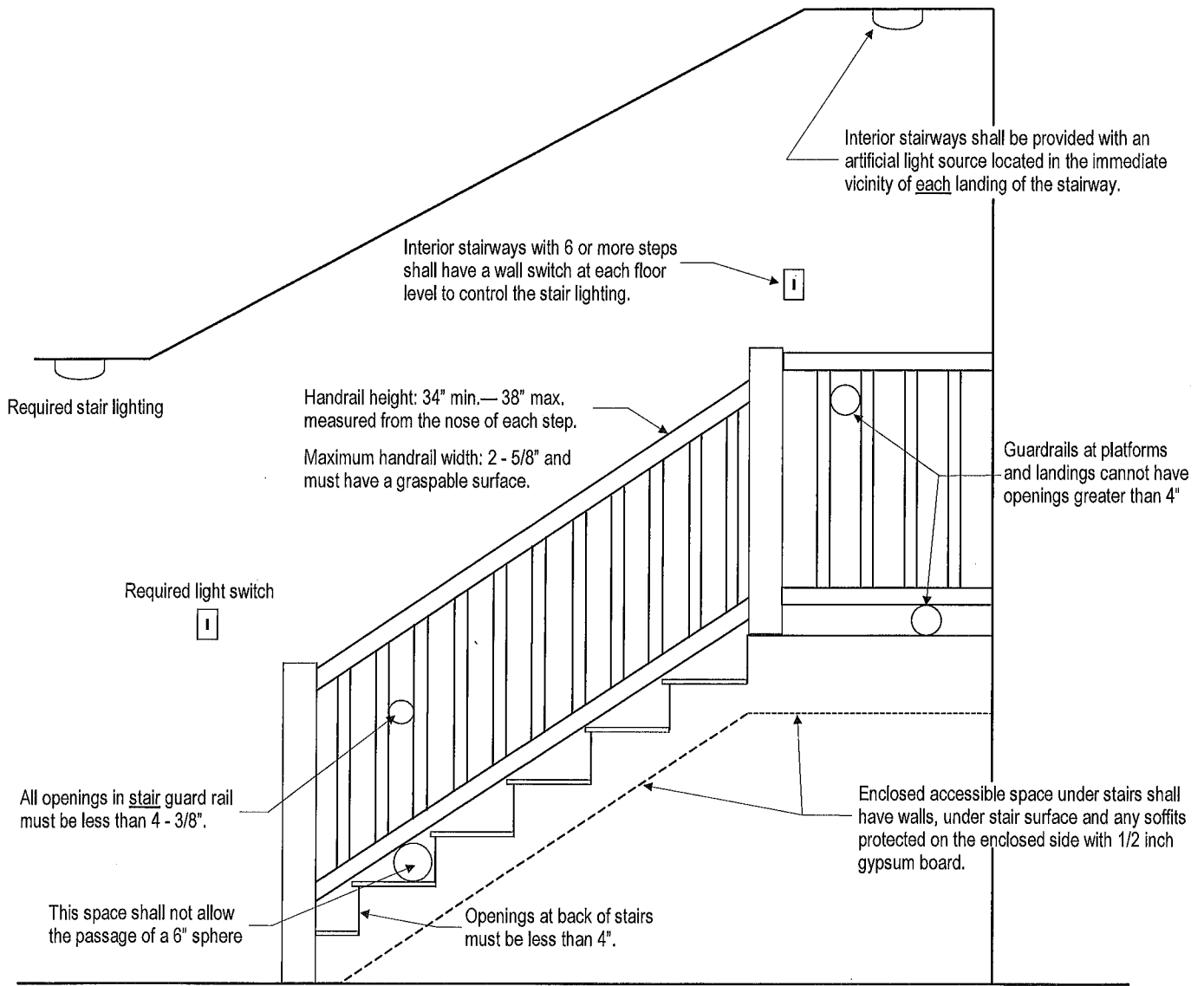

INTERIOR STAIR DETAIL

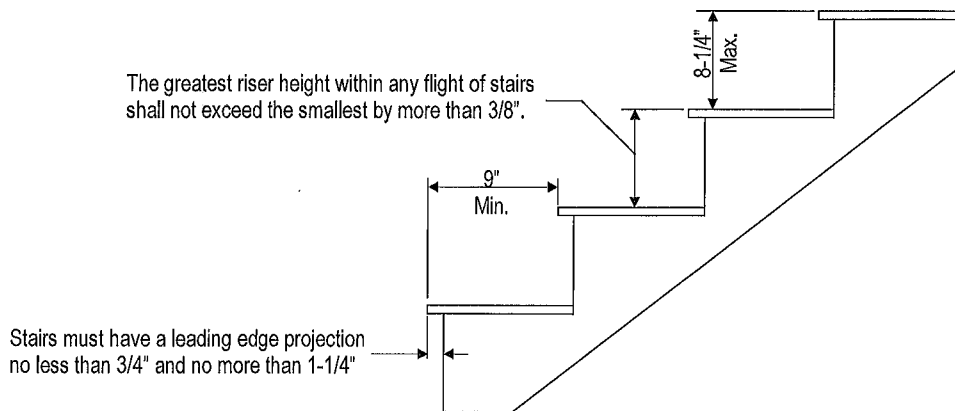

TREAD AND RISER DETAIL

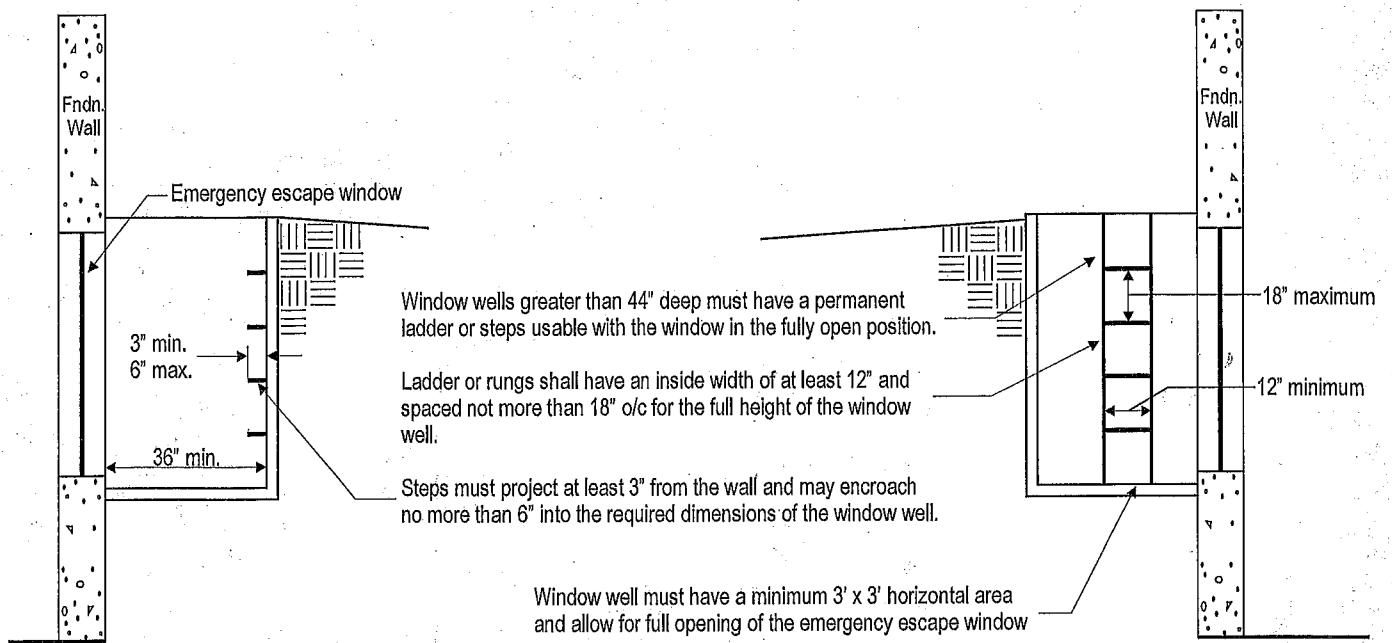

EMERGENCY ESCAPE WINDOW WELL DETAIL

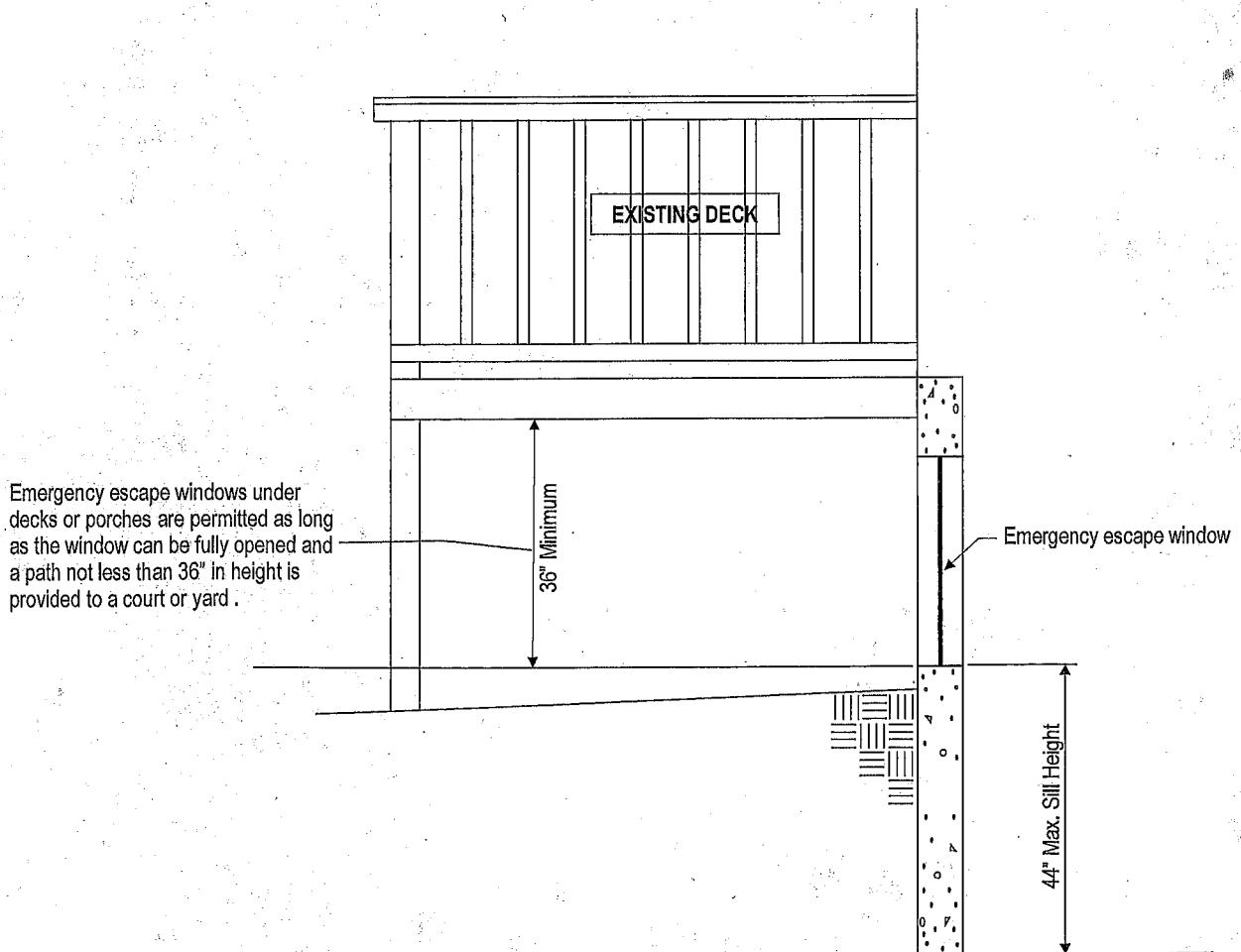

EMERGENCY ESCAPE WINDOW UNDER EXISTING STRUCTURES