

GARY W. MOORE  
COUNTY JUDGE/EXECUTIVE

JEFFREY S. EARLYWINE  
COUNTY ADMINISTRATOR



**BOONE COUNTY**  
**BUILDING INSPECTION**

JERALD E. NORAN  
CHIEF BUILDING OFFICIAL

*BOONECOUNTYKY.ORG*

**BOONE COUNTY BUILDING DEPARTMENT**  
**ACKNOWLEDGEMENT OF POST & FRAME STRUCTURES**

PERMIT #: \_\_\_\_\_

ADDRESS: \_\_\_\_\_

I hereby acknowledge that I have read the attached information about code requirements for Post and Frame Structures (Pole Barns) as required by the 2018 Kentucky Residential Code.

We understand and agree to comply with all Pole Barn regulations, regardless of any contractual obligations between the parties.

\_\_\_\_\_  
OWNERS SIGNATURE

\_\_\_\_\_  
CONTRACTOR SIGNATURE

\_\_\_\_\_  
PRINT OWNER NAME

\_\_\_\_\_  
PRINT CONTRACTOR NAME

\_\_\_\_\_  
DATE

\_\_\_\_\_  
DATE



# BOONE COUNTY

## BUILDING INSPECTION

*BOONECOUNTYKY.ORG*

### GENERAL REQUIREMENTS FOR POST AND FRAME STRUCTURE (POLE BARNS) 2018 KENTUCKY RESIDENTIAL CODES SECTION 327

Address of Project \_\_\_\_\_ Application # \_\_\_\_\_

Applicant's Name (Printed) \_\_\_\_\_ Signature \_\_\_\_\_

This document, when signed and initialed, will become part of the application for permit. The requirements on this document will take precedence over any discrepancies within the documents. All items shall be checked, and the signature of the Applicant above indicates agreement with all of the stated requirements.

The following items are supplemental construction notes provided by, the Boone County Building Department based on the minimum requirements of the 2018 Kentucky Residential Code Section 327.

DIMENSION OF BUILDING:

---

SIZE OF TREATED POSTS & DEPTH + WIDTH:

---

(See Pole Barn Specs. On Footer)

TYPE OF ROOF FRAMING:

---

TYPE OF ROOFING MATERIAL:

---

NUMBER & SIZE OF DOORS:

---

SLAB THICKNESS AND DEPTH:

---

**NOTES:**

- NO ATTIC STORAGE
- MAXIMUM BUILDING WIDTH OF 48 FEET INCLUDING THE OVERHANG
- MAXIMUM WALL HEIGHT OF 16 FEET
- MAXIMUM MEAN ROOF HEIGHT OF 20 FEET
- MAXIMUM POST SPACING OF 8 FEET
- **FOOTERS SHALL BE AT LEAST 48" BELOW GRADE**
- PLEASE SEE ATTACH SHEETS FOR OTHER REQUIREMENTS

Post and frame structures and portions thereof outside the above structural limitations of this standard shall be accompanied by structural calculations as required by the residential building official or designed under the provisions of section R116.2 of the Kentucky Residential Code.

**INSPECTIONS THAT ARE REQUIRED: 24 hour notice for inspection and please have permit number when calling for these inspections:**

1. Footing holes and uplift protection
2. If electrical work is done, please have this inspected before you call for final inspection
3. Final inspection

**DISCLAIMER:**

This worksheet highlights specific sections of the 2018 Kentucky Residential Code in order to facilitate plan submission. It is not intended to be a complete summary of that document.

shall not exceed 4 inches (102 mm) in width.

5. Where the barrier is composed of horizontal and vertical members, and the distance between the tops of the horizontal members is 24 inches (610 mm) or more, spacing between vertical members shall not exceed 4 inches (102 mm). Where there are decorative cutouts within vertical members, spacing within the cutouts shall not exceed 1 3/4 inches (44 mm) in width.
6. Maximum mesh size for chain link fences shall be a 2 1/4-inch (57 mm) square, unless the fence has slats fastened at the top or the bottom which reduce the openings to not more than 1 3/4 inches (44 mm).
7. Where the barrier is composed of diagonal members, such as a lattice fence, the maximum opening formed by the diagonal members shall not be more than 1 3/4 inches (44 mm).
8. Access gates shall comply with the requirements of items 1 through 7, and shall be equipped to accommodate a locking device. Pedestrian access gates shall open outward away from the *swimming pool*, and shall be self-closing and have a self-latching device. Gates, other than pedestrian access gates, shall have a self-latching device. Where the release mechanism of the self-latching device is located less than 48 inches (1219 mm) above grade from the bottom of the gate, the release mechanism and openings shall comply with the following:
  - 8.1. The release mechanism shall be located on the *swimming pool* side of the gate at least 3 inches (76 mm) below the top of the gate; and
  - 8.2. The gate and barrier shall have no opening larger than 1/2 inch (12.7 mm) within 18 inches (457 mm) of the release mechanism.
9. Where a wall of a dwelling serves as part of the barrier, one of the following conditions shall be met:
  - 9.1. The *swimming pool* shall be equipped with a powered safety cover in compliance with ASTM F 1346;
  - 9.2. Doors with direct access to the *swimming pool* through that wall shall be equipped with an alarm that produces an audible warning when the door and its screen, if present, are opened. The alarm shall be listed and labeled in accordance with UL 2017. The deactivation switch(es) shall be located at least 54 inches (1372 mm) above the threshold of the door; or
  - 9.3. Other means of protection, such as self-closing doors with self-latching devices, which are approved by the

authority having jurisdiction, shall be acceptable as long as the degree of protection afforded is not less than the protection afforded by Item 9.1 or 9.2 described herein.

**R326.8.2 Indoor swimming pool.** Walls surrounding an indoor *swimming pool* shall comply with Item 9 of Section R926.6.2.

**R326.8.3 Prohibited locations.** Barriers shall be located to prohibit permanent structures, *equipment*, or similar objects from being used to climb them.

**R326.8.4 Barrier exceptions.** *Spas* or *hot tubs* with a safety cover that comply with ASTM F 1346 shall be exempt from the provisions of this section.

**R326.9 Locations.** Private *swimming pools* shall not encroach on any front or side yard required by this code or by the governing zoning laws, unless in accordance with specific rules of the *jurisdiction* in which the *swimming pool* is located. A wall of a *swimming pool* shall not be located less than 6 feet (1829mm) from any rear or side property lines or 10 feet (3048mm) from any street property line, unless in accordance with the specific rules of the *jurisdiction* in which the *swimming pool* is located.

**R326.10 Entrapment Protection for Swimming Pool and Spa Suction Outlets.** Suction outlets shall be designed and installed in accordance with ANSI/APSP-7.

## SECTION R327 POST AND FRAME STRUCTURES

**R327.1 Post and frame structures.** The following requirements serve as minimum standards for post and frame structures within all of the following structural limitations:

1. Residential accessory structures;
2. Single story;
3. Metal roof on purlins with bracing and metal wall panels on girts, with bracing as shown in Figure R327.1 or in lieu of bracing provide solid exterior structural sheathing;
4. No attic storage;
5. Maximum building width of 48 feet including the overhang;
6. Maximum wall height of 16 feet;
7. Maximum mean roof height of 20 feet; and
8. Maximum post spacing of 8 feet.

Post and frame structures and portions thereof outside the above structural limitations of this standard shall be accompanied by structural calculations as required by the residential *building official* or designed under the provisions of section R106.1 of this code. Post and

frame structure shall comply with the structural design requirements of Section R301 of this code or the alternative provisions (Post Frame Building Design Manual) referenced in Section 301.1.1.

**R327.2 Definition.** Post and frame structures consist of primary members (post, beams and single span trusses or ceiling joists and rafters) and secondary members (roof purlins, wall girts, bracing, and sheathing) where all loads are transmitted from the sheathing and the secondary members to the primary members, which transfer them to the ground through vertical posts bearing on footings embedded in the soil. See Figure R327.1.

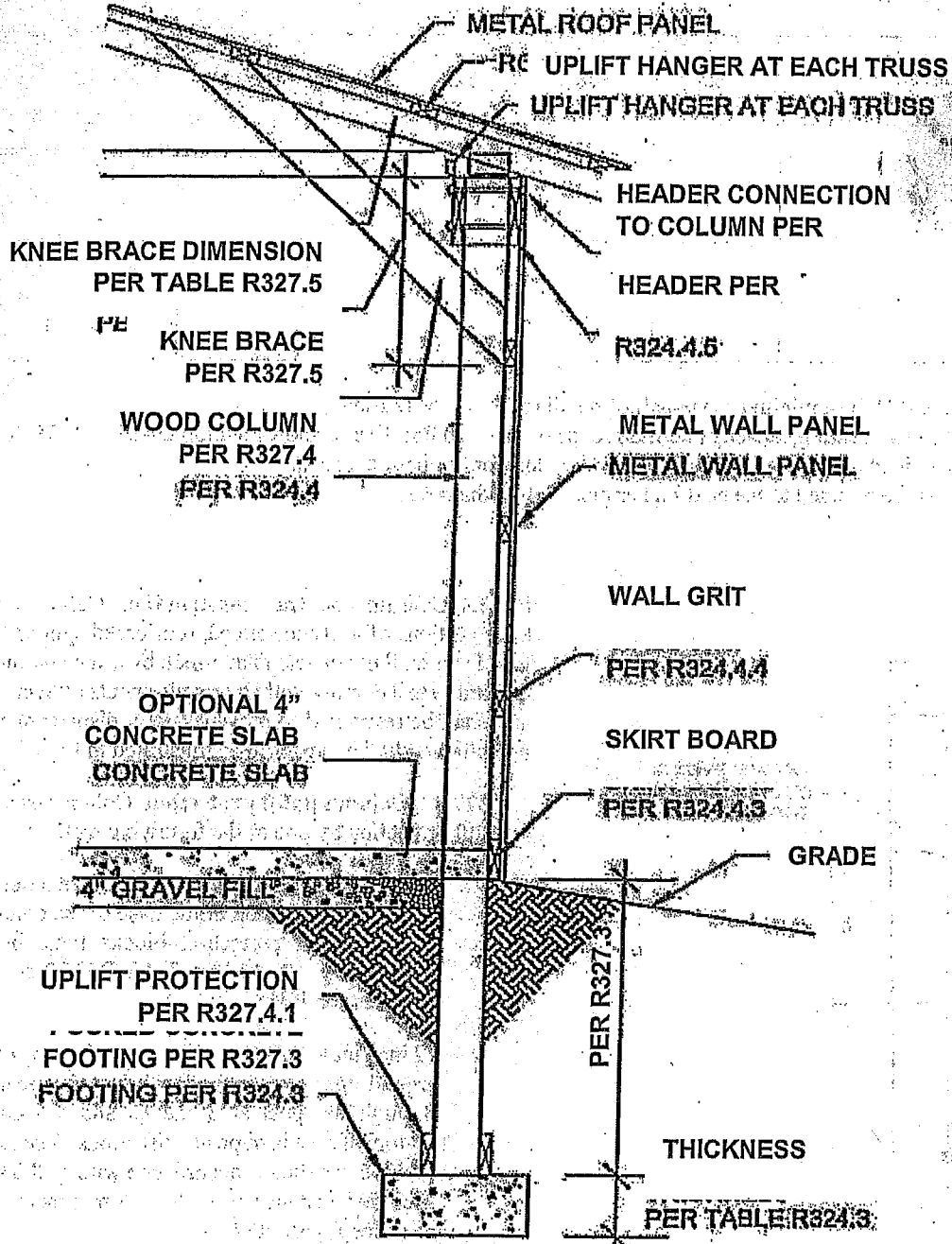

PER TABLE R327.3  
 PER TABLE R324.3  
 FIGURE R327.1

POST AND FRAME WALL SECTION  
 NO SCALE

BRACING NOT SHOWN

**TABLE R327.3  
POST FRAME PIER DIAMETERS**

	Building width (length of truss) including overhang (feet)						
	25	28	32	36	40	44	48
Diameter (inches) 20 lb. Roof Snow Load	18	22	24	26	28	28	30
Diameter (inches) 30 lb. Roof Snow Load	24	26	28	28	30	30	32

1. Pier footing thickness shall be a minimum one-half of the diameter of the footing.
2. Based upon 2000 PSF soil bearing capacity and truss loads of 20 or 30 PSF live or snow load top chord, 10 PSF dead load top chord, 5 PSF dead load on the bottom chord and no live load on the bottom chord.
3. Fractional widths shall be rounded to the next higher pier footing diameter.

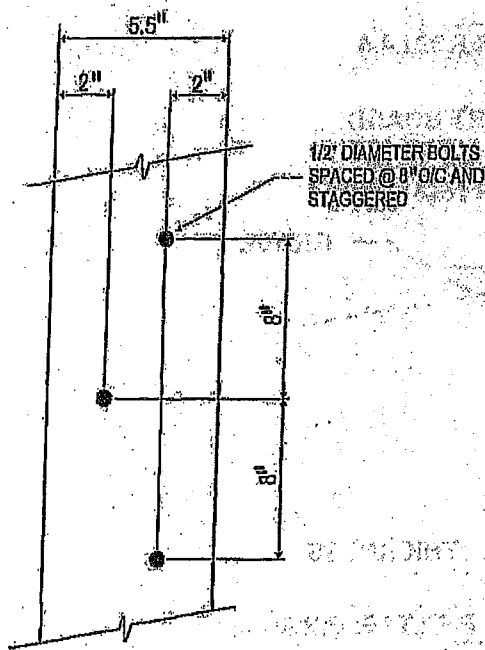

**BUILT UP COLUMN FASTENING DETAIL  
FIGURE R327.2**

**R327.3 Footings and Foundations.** Footings and foundations shall comply with applicable provisions of R401. Post and frame structures shall have poured in-place concrete footings installed below all posts. The top of the footing shall be a minimum of 48 inches below finished grade and have footing diameters complying with Table R327.3.

**R327.4 Column and wall construction.** Columns shall be three sections of 4-ply unspliced, reinforced spliced, or solid wood and shall not be less than 6-inch by 6-inch nominal size. Columns shall comply with the requirements of Section R318 and shall be restrained to prevent lateral displacement. Built up columns shall be fastened as illustrated in Figure R327.2.

**R327.4.1 Column uplift protection.** Columns shall have uplift protection by one of the following methods:

1. Two 2x6 12-inch column uplift protection blocks attached to each side of the base of the column. The column uplift protection blocks must be placed horizontally, attached per Table R327.7 and comply with Section R318.
2. 12 inch high, concrete collar poured on top of footing around the post with 2 #5x9-inch rebar placed through the post at 3 inches and 9 inches from bottom of post in opposite directions. The rebar ends shall be installed in accordance with ACI 332 for the specified distance in inches from contact with the soil. See Figure R327.3

**R327.4.2 Column spacing.** The maximum spacing for columns shall be 8 feet.

**R327.4.3 Skirt boards.** Skirt boards shall be treated lumber meeting the requirements of Section R318 and attached per Table R327.7.

**R327.4.4 Wall girts.** Girts shall be a minimum 2x4 spaced not more than 24 inches on center and attached per Table R327.7.

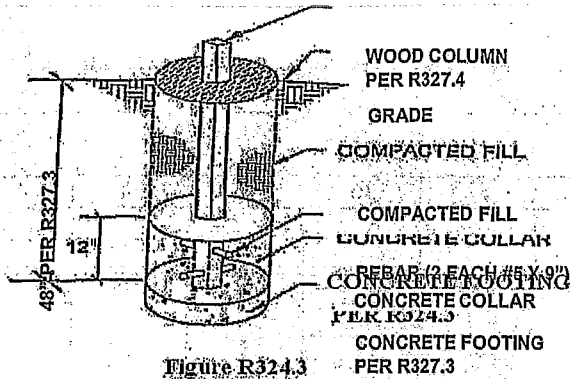

Figure R327.3  
Column Uplift Protection Exception  
FIGURE R327.3

**COLUMN UPLIFT PROTECTION EXCEPTION**  
NO SCALE

**R327.4.5 Load bearing beams and headers.** Load bearing beams and headers shall comply with Table R502.5 (1).

**Exceptions:**

1. Bearing beams are not required if the trusses or ceiling joists and rafters bear directly on the columns.
2. Opening on the gable end walls of post and frame buildings supporting a door or roof total load not exceeding 5 square feet per lineal feet of wall area, headers must be sized per Table R327.4.5.

**TABLE R327.4.5**  
**GABLE END HEADER SIZES**

Opening Width (feet)	10	12	16
Header Size (inches)	2 - 2x8	2 - 2x10	2 - 2x12

**R327.4.6 Exterior Structural Sheathing or Wall Bracing.** Provide exterior structural sheathing or wall bracing to resist all racking and shear forces. Bracing must comply with the applicable provisions of section R602.10 or by installing 2x6 diagonal braces between two adjoining columns at 8 feet on center or multiple spacing totaling a minimum of 8 feet on center where the post spacing design is less than 8 feet on center. The diagonal brace shall be placed from the top header or girt to the next adjoining column at the skirt board. The bracing shall be installed on each side of the building and shall be a minimum of 25 feet on center and within 12 feet of the end of the building and attached to the wall girts and columns per Table R327.7. Any splices of the diagonal brace required due to excessive length, must lap over two consecutive wall girts.

**R327.4.7 Beams supporting trusses or rafters and ceiling joists attachment to column.** Bearing beams supporting roof trusses or rafters and ceiling joists shall be connected to columns by one of the following methods:

1. Bolts that are 1/2 inch diameter through-bolted to the side of the column;
2. Bolts that are 1/2 inch diameter, directly attached to a 3-ply column notch, enclosing the truss or rafter at the top of column; or
3. Other fasteners with minimum shear or withdraw values stated in Table R327.4.7.

**R327.4.7.1 Number of fasteners.** The minimum numbers of through bolts or the fasteners with minimum shears or withdraw values required per Table R327.4.7.

**R327.5 Knee bracing.** A 2x6 brace shall extend from the column to the top chord of the truss or rafter adjacent to the post at a 45 degree angle. The vertical distance down from the bottom chord of the truss or ceiling joist to the point where the brace attaches to the post shall be in compliance with Table R327.5 as shown on Figure R327.1. Trusses or rafter must be spaced such that they align with the column intervals. Attachment of knee brace shall be per Table R327.7.

**TABLE R327.5**  
**KNEE BRACE VERTICAL DISTANCE**

Wall Height	Vertical Dimension
8'-0" and 9'-0"	1'-6"
10'-0" and 11'-0"	2'-0"
12'-0" and 13'-0"	3'-0"
14'-0" through 16'-0"	4'-0"

**R327.6 Roof Construction.** Top chord of roof trusses or roof rafters shall be braced with exterior sheathing or metal roof on purlins with bracing.

**R327.6.1 Roof Purlins.** Roof purlins shall be a minimum of 4x2 SPF #2 laid flat of spans up to 4 feet, and 4x2 SPF #2 laid on edge for spans up to 8 feet.

**R327.6.2 Roof Bracing.** Provide exterior structural sheathing or bracing to resist racking and shearing forces in roof bracing shall occur in the roof on all 4 sides of the building and shall consist of 2x6 diagonal braces perpendicular and parallel to rafters or trusses and attached to the bottom side of rafters or top chords of trusses. These braces shall start at a point just below the first purlin, rafter, or truss in from the eave purlin and at each corner column. The brace shall be placed on a 45-degree angle and end below the location of a purlin, rafter, or truss within 8'-0" in from the wall. If the building width or length exceeds 24'-0" then install additional braces in the same manner. Spacing of braces shall not exceed a maximum spacing of 2 feet on center in any direction.

**R327.7 Attachment details.** Structural fastener details for post and frame buildings shall comply with Table R327.7.

**TABLE R327.4.7  
BEAM OR TRUSS CONNECTION AT COLUMNS MINIMUM FASTENERS OR TOTAL SHEAR OR  
WITHDRAW VALUES**

Building width (length of truss) including overhang (feet)							
	24	28	32	36	40	44	48
Shear or withdraw (pounds) 20# snow load	3360	3920	4480	5040	5600	6160	6720
Number of Bolts 20# roof snow load	2	2	2	3	3	3	3
Shear or withdraw (pounds) 30# roof snow load	4320	5040	5760	6480	7200	7920	8640
Number of Bolts 30# roof snow load	2	3	3	3	3	3	3

1. Based upon truss loads of 20 or 30 PSF live or snow load top chord, 10 PSF dead load top chord, 5 PSF live load on the bottom chord and no live load on the bottom chord.
2. Based upon post spacing at intervals not exceeding 8 feet.
3. When beams are attached at each side of the column and fasteners do not extend through both beams such as through-bolts, the required values are one-half the amount shown above for each beam.

**TABLE R327.7  
FASTENER SCHEDULE FOR STRUCTURAL MEMBERS**

Fastener Schedule for Structural Members		
Description of Building Element	Number and Type of Fastener	Attachment Type
Uplift blocking to column	5 - 16d Hot Dipped Galvanized	Each block
Skirt board to column	2 - 16d Hot Dipped Galvanized	Face nail
Wall girt to column	2 - 16d Hot Dipped Galvanized	Face nail
Diagonal bracing to column	2 - 16d Hot Dipped Galvanized	Toe nail
Diagonal bracing to skirt board	2 - 16d Hot Dipped Galvanized	Face nail
Diagonal bracing to wall girts	2 - 10d Hot Dipped Galvanized	Face nail
Knee brace to column	2 - 10d	Face nail
Knee brace to top chord of truss or rafter	3 - 16d Hot Dipped Galvanized	Face nail
Knee brace to bottom chord of truss or ceiling joist	3 - 10d	Face nail
Roof purlin to truss or rafter with span of 2' or 4'	2 - 16d	Face nail
Roof purlin to truss or rafter with span of 8'	Mechanical fastener with uplift protection greater than 225 lbs	Per manufacturer