



BOONE COUNTY

KENTUCKY

**AMERICANS WITH DISABILITIES ACT
(ADA)**

**TRANSITION PLAN FOR
PUBLIC FACILITIES &
PUBLIC RIGHT-OF-WAY**

**BOONE COUNTY FISCAL COURT
BOONE COUNTY, KENTUCKY**



BOONE COUNTY
KENTUCKY

Americans with Disabilities Act (ADA)
Transition Plan for Public Facilities & Public Right-of-Way

First Draft Completed: May 25, 2016
Final Draft Completed: August 12, 2016

Final Plan Adopted: October 4, 2016

Judge/Executive

Gary W. Moore

County Commissioners

Cathy Flaig

Dr. Charles Kenner

Charlie Walton

Transition Plan Contents

I.	Introduction	4
II.	ADA Program	5
	a. Responsible Official	
	b. Self-Evaluation	
	c. Public Engagement	
	d. Grievances	
	e. Annual Evaluation/Public Notice	
III.	ADA Transition Plan for Public Facilities	7
	a. Self-Evaluation	
	b. Corrective Program	
	c. Program Responsibility	
IV.	ADA Transition Plan for Public Right-of-Way	10
	a. Self-Evaluation	
	b. Corrective Program	
	c. Program Responsibility	
V.	Implementation and Funding	14
	a. Implementation/Funding	
	b. Funding Sources	
VI.	Attachments	16
	A. Public Facilities	
	1. Checklists	
	2. Self-Evaluation Findings (TBD)	
	B. Public Right-of-Way	
	a) Sidewalk Ramp Specifications	
	b) Self-Evaluation Findings	
	C. Sample Forms	
	1. Grievance Form	

I. Introduction

The Americans with Disabilities Act (ADA) of 1990 is a civil rights statute that prohibits discrimination against people who have disabilities. There are five separate Titles, or sections, of the Act that cover different aspects of potential discrimination. These include: Title I – Employment, Title II – Public Services and Transportation, Title III – Public Accommodations, Title IV – Telecommunications, Title V – Miscellaneous. Title II of the Act specifically addresses the subject of making public services and public transportation accessible to those with disabilities. Designing and constructing facilities for public use that are not accessible by people with disabilities constitutes discrimination.

The Americans with Disabilities Act applies to all facilities, including both facilities built before and after 1990. State and local government and public entities or agencies are required to perform self-evaluations of their current facilities, relative to the accessibility requirements of the current ADA accessibility standards (http://www.ada.gov/2010ADASTstandards_index.htm). The goal of this process is to ensure that public buildings, parking lots, parks, recreational facilities and public right-of-way are accessible to and usable by people with disabilities.

Per the Act, public agencies are required to develop a Program Access Plan (also called a Transition Plan) to address any deficiencies that exist and to update the Plan periodically.

The Boone County Transition Plan is intended to achieve the following:

- Identify barriers limiting the accessibility of facilities to individuals with disabilities,
- Describe the methods to be used to address those barriers,
- Provide a schedule for making modifications, and
- Identify the public officials responsible for Plan implementation.

The requirements of the ADA apply to all public entities or agencies, no matter the size. The transition plan formal procedures as outlined in 28 C.F.R. section 35.150 only govern those public entities with more than 50 employees.

II. ADA Program

a. Responsible Official

The Boone County Transition Plan is only one component of the County's ADA compliance strategy. The Boone County Director of Human Resources is charged with oversight of the County's ADA policies and procedures. The Transition Plan is created and implemented in conjunction with the Boone County ADA Steering Committee comprised of the Director of Human Resources, Chief Building Official, Director of Public Works/County Engineer, Public Works Engineering Services Supervisor, Director of Parks & Recreation and the Director of Property Maintenance.

b. Self-Evaluation

As required by the Americans with Disabilities Act, Boone County Fiscal Court has directed that a self-evaluation exercise of its programs, services, and activities would begin in 2016 and be completed by 2018 to insure that all that all public buildings, parking lots, parks, recreational facilities and public right-of-way are accessible to and usable by persons with disabilities. To effectively facilitate this process, two ADA evaluation teams were established, one for public facilities and one for public right-of-way.

An Action Plan will be completed listing specific policy or program modifications needed, and target dates by which those changes are to be made. Any new construction and or major repairs will be required to meet these ADA standards for accessibility.

c. Public Engagement

The public is encouraged to identify ADA accessibility issues and report them to the County using the citizen feedback link on the County website. In addition, a public hearing will be scheduled annually to specifically solicit comments, concerns and suggestions from the public as they pertain to the accessibility within public facilities and public right-of-way.

d. Grievances

This Grievance Procedure is established to meet the requirements of the Americans with Disabilities Act of 1990 ("ADA"). It may be used by anyone who wishes to file a complaint alleging discrimination on the basis of disability in the provision of services or benefits within public facilities. Any citizen who believes a building, parking lot, park, recreational facility or public right-of-way does not meet specifications for accommodation may submit a complaint in writing that contains information about the alleged discrimination such as name, address, phone number of complainant and location, date, and description of the problem. Alternative means of filing complaints will be made available for persons with disabilities upon request.

Complaints should be directed to: Human Resources Department
 Boone County Fiscal Court
 PO Box 900, 2950 Washington St.
 Burlington, KY 41005

A designated staff member will meet with the complainant within 10 working days of receipt of the complaint to discuss the issues and possible resolution. Within 10 working days, a statement will be issued to complainant outlining the findings and describing the course action to be followed by the County in response and consistent with this plan. Complainant shall have the right to appeal the decision to the Assistant County Administrator.

e. Public Notice.

Agencies are required to give notice to the public on information regarding public accessibility and compliance with ADA. Upon adoption, the ADA Transition Plan for Public Facilities & Public Right-of-Way will be provided on the Boone County website. The Boone County ADA Transition Plan for Public Facilities & Public Right- Of-Way will be utilized in yearly planning of projects and funding decisions, and also will be periodically reviewed for compliance and validity. The Transition Plan should be viewed as a "living document" and updated regularly. Boone County will hold a public hearing annually to solicit input and comments from the public to assist with the review and update of the plan. The public hearing will be advertised to the public.

III. ADA Transition Plan for Public Facilities

The Boone County ADA Transition Plan for Public Facilities is comprised of the following elements:

- a) Self-Evaluation
- b) Corrective Action Program
- c) Program Responsibility

a. Self- Evaluation

The first step in preparing the Boone County ADA Transition Plan for Public Facilities is to conduct an inventory of current barriers within public facilities that negatively impact accessibility. The Chief Building Official is tasked with completing this assessment of public facilities and will utilize the Boone County ADA Facilities Evaluation Team comprised of Building Department inspection staff, Property Maintenance Director and the Parks Superintendent to accomplish the review. The self-evaluation will begin in August 2016 and will be completed no later than September 1, 2017. The Boone County ADA Transition Plan for Public Facilities & Public right-of-Way will be updated quarterly.

For public buildings, this evaluation will include determining if there is an accessible route into the building, comprised of exterior signage, accessible parking, accessible sidewalks and/or ramps, and an accessible building entrance. This evaluation will also include interior building elements such as doors, doorways and door hardware; vertical circulation elements: ramps, elevators and stairs; plumbing fixtures, including drinking fountains, sinks, toilets and urinals; service counters; and interior signage.

For parks and recreational facilities, accessibility will be evaluated for parking lots, walking paths, boating slips and fishing piers, golf course cart paths, shelters and restrooms facilities, playground entrances and play equipment, swimming pool access and showers, and any exercise equipment/stations that may be provided.

Checklists are included in Section VI of this plan.

b. Corrective Action

Once identified as a deficiency to accessibility, the item shall be assessed and ranked based on a prioritization schedule (provided below). Action will be planned based on a combination of the priority, funding plan and the frequency of use of the individual facility by the public.

Priority 1 items consist of barriers that would make reasonable use of the facility impossible, or extremely difficult without assistance. Priority 2 items are those barriers that make unassisted use of the facility difficult, but that can be overcome. Priority 3 items are those items that are considered necessary for full accessibility, but would not constitute a physical barrier.

Priority	Element	Deficiency
1	Door/doorway	Width, hardware, opening force, approach space
	Curb ramp	Missing, slope, landings
	Restrooms	Accessible fixtures, grab bars
	Sidewalk/ramp	Missing, width, handrails, slope, cross-slope
	Elevator	Missing, controls, signals
	Pool	Access (lift, ramp)
2	Parking space	Width, length, vertical clearance, access aisle
	Van parking	Width, length, vertical clearance, access aisle
	Counter	Height, width, writing surface
	Playground	Entrance, play equipment, surface
	Golf course	Cart path width, shelter, restroom
	Corridor	Width, turning radius
3	Pkg. Signage	Missing, height, van accessible
	Interior Signs	Missing, height, Braille lettering
	Boat/Fishing Pier	Edge protection, openings, width, turning radius
	Exercise equipment	Clear floor area

Example of Self-Evaluation

Location	Deficiency Type	Date Noted	Remediation Plan

c. Program Responsibility

The public facilities component of the ADA Transition Plan for Public Facilities & Public Right-of-Way is monitored and coordinated by the Boone County ADA Coordinator with assistance from the Boone County Chief Building Official and the Boone County ADA Steering Committee comprised of the Director of Human Resources, Chief Building Official, Director of Public Works/County Engineer, Public Works Engineering Services Supervisor, Director of Parks & Recreation and the Director of Property Maintenance.

Boone County ADA Coordinator
Lori Zombek
Human Resources
PO Box 900, 2950 Washington Street
Burlington, KY 41005
859-334-2100

Boone County Building Department
Jerald Noran
Chief Building Official
PO Box 900, 2950 Washington Street
Burlington, KY 41005
859-334-2218

IV. ADA Transition Plan for Public Right-of-Way

The Boone County ADA Transition Plan for Public Right-of- Way is comprised of the following elements:

- a. Self-Evaluation
- b. Corrective Action Program
- c. Program Responsibility

a. Self- Evaluation

The first step in preparing the Boone County ADA Transition Plan for Public Right-of-Way is to conduct an inventory of current barriers within the public right-of-way that negatively impact accessibility. The Director of Public Works/County Engineer is tasked with completing this assessment of County-maintained pedestrian access routes (curb ramps and sidewalks) and will utilize Public Works staff with the assistance of the County's Traffic Safety Committee to accomplish the review. The self-evaluation will begin in August 2016 and will be complete no later than September 1, 2017. The Boone County ADA Transition Plan for Public Facilities & Public Right-of-Way will be updated quarterly.

Pedestrian Access Routes and Curb Ramps

The evaluation will utilize a standard of at least 4 feet wide with a maximum cross slope of 2% with transition markings to ensure accessibility in public right-of-way. Pedestrian access routes and curb ramps will be evaluated visually for potential accessibility deficiencies. The following chart illustrates potential issues that would need remediation followed by a chart indicating existing pedestrian access routes/curb ramps that were found to be deficient:

Type	Issue
Sidewalk Deficiency	Narrow, Below Guidelines
Sidewalk Deficiency	Steepness, Irregularity, Variability, Warping Caused by Cross Slope
Sidewalk Deficiency	Obstruction (Signs, Mail Boxes, Fire Hydrants, Benches, Traffic Signal Poles, Traffic Signal Controller Boxes, Newspaper Boxes, Drainage Structures, Standing Water, Snow or Ice)
Sidewalk Deficiency	Surface Deterioration/ Poor Markings
Sidewalk Deficiency	Gaps, Drops, Steps, Missing Sections
Curb Ramp Deficiency	Missing Curb Ramp
Curb Ramp Deficiency	Misalignment of Crosswalk
Curb Ramp Deficiency	No Transition Warning Pad
Curb Ramp Deficiency	Steep Ramp
Curb Ramp Deficiency	Landing Less than 4 X4 Feet/ Steepness
Curb Ramp Deficiency	Warning System – Missing/Not Operable
Curb Ramp Deficiency	Traffic Signal System- Inoperable or Inaccessible Buttons
Curb Ramp Deficiency	Traffic Signal Not Equipped for Visually Impaired
Curb Ramp Deficiency	Traffic Signal Not Appropriately Timed
Curb Ramp Deficiency	Missing Curb Ramp Flares

Example of Self-Evaluation

Location	Deficiency Type	Date Noted	Remediation Plan

Pedestrian Signals

Boone County maintains very few traffic lights/ pedestrian signals on County routes. Where pedestrian signals are provided at pedestrian street crossings,

they must include accessible pedestrian signals and pedestrian pushbuttons meeting MUTCD criteria per the proposed guidelines for accessible public right-of-way.

b. Corrective Action Program

Once identified as a deficiency to accessibility, the item shall be assessed and ranked based on a prioritization schedule (provided below). Action will be planned based on a combination of the priority and funding plan.

Priority	Issue	Deficiency Type
(Highest)		
1	Missing Curb Ramp	Curb Ramp Deficiency
2	No Transition Warning Pad	Curb Ramp Deficiency
3	Obstruction (Signs, Mail Boxes, Fire Hydrants, Benches, Traffic Signal Poles, Traffic Signal Controller Boxes, Newspaper Boxes, Drainage Structures, Standing Water, Snow or Ice)	Sidewalk Deficiency
4	Steepness, Irregularity, Variability, Warping Caused by Cross Slope	Sidewalk Deficiency
5	Surface Deterioration/ Poor Markings	Sidewalk Deficiency
6	Misalignment of Crosswalk	Curb Ramp Deficiency
7	Landing Less Than 4 X4 Feet/ Steepness	Curb Ramp Deficiency
8	Gaps, Drops, Steps, Missing Sections	Sidewalk Deficiency
9	Warning System – Missing/Not Operable	Curb Ramp Deficiency
10	Steep Ramp	Curb Ramp Deficiency
11	Traffic Signal System- Inoperable or Inaccessible Buttons	Curb Ramp Deficiency
12	Narrow, Below Guidelines	Sidewalk Deficiency
13	Traffic Signal Not Equipped for Visually Impaired	Curb Ramp Deficiency
14	Traffic Signal Not Appropriately Timed	Curb Ramp Deficiency
15	Missing Curb Ramp Flares	Curb Ramp Deficiency
(Lowest)		

c. Program Responsibility

The public right-of-way component of the ADA Transition Plan for Public Facilities and Public Right-of-Way is monitored and coordinated by the Boone County ADA Coordinator with assistance from the Boone County Director of Public Works/County Engineer and the Boone County ADA Steering Committee comprised of the Director of Human Resources, Chief Building Official, Director of Public Works/County Engineer, Public Works Engineering Services Supervisor, Parks Director and the Property Maintenance Director. Coordination is provided for State and Federal roads by the Kentucky Transportation Cabinet District Office (District 6).

Boone County ADA Coordinator

Lori Zombek
Human Resources
PO Box 900, 2950 Washington Street
Burlington, KY 41005
859-334-2100

Boone County Public Works/County Engineer

Scott Pennington
Public Works Department
5645 Idlewild Road
Burlington, KY 41005
859-334-3600

Kentucky Transportation Cabinet, District 6

ADA Coordinator
421 Buttermilk Pike
Ft. Mitchell KY 41017
Phone: (859) 341-2700

V. Implementation & Funding

a. Implementation and Funding

Boone County has committed to the following funding and implementation schedule:

1. All new construction and major repairs that impact County Facilities will be completed in compliance with ADA requirements for accessibility. Cost will be included with project estimates.
2. Funds will be allocated for implementation of updates needed for existing impediments to accessibility in County Facilities as described in the chart below.
3. Funds will be allocated to address highest priority items within the ADA Transition Plan for Public Facilities & Public Right-of-Way as recommended by the ADA Transition Plan steering committee and approved by the Boone County Fiscal Court.

Project Type	Funding Cycle	Anticipated Budget
New Construction	Indefinite	Cost of Project
Existing Compliance Issues	July 2017-2019	\$100,000
	July 2019-2021	\$100,000
	July 2021-2023	\$200,000
	July 2023-2025	\$200,000
	July 2025-2027	\$200,000

	July 2027-2037	\$1,000,000
Total Anticipated Allocation for 2017-2037		\$1,800,000

b. Funding Sources

Potential Sources for funding the ADA Transition Plan include, but are not limited to:

- Boone County Capital Improvement Fund
- SNK Federal Transportation Funding
- Transportation Alternatives Program
- Transportation Enhancements Program
- Congestion Mitigation/ Air Quality Program
- Surface Transportation Program
- Other applicable Federal, State, Local Grants

Comments and Questions

Boone County ADA Coordinator
 Department of Human Resources
 PO Box 900, 2950 Washington Street
 859-334-2100

VI. Attachments

- A. 1. Public Facilities Checklists
- A.2. Public Facilities Self-Evaluation Findings
- B.1. Public Right-of-Way Sidewalk Ramp Specifications
- B.2 Public Right-of-Way Self-Evaluation Findings
- C.1 Grievance Form

Attachment A 1: PUBLIC FACILITIES CHECKLISTS

CHECKLIST: ADA TRANSITION PLAN FOR PUBLIC RECREATIONAL FACILITIES

FACILITY NAME _____ FACILITY ADDRESS _____

COMPLIANCE

Total Partial Non N/A Notes

BOAT SLIPS

60" Width & Openings	<input type="checkbox"/>	<input type="checkbox"/>	<input type="checkbox"/>	<input checked="" type="checkbox"/>	_____
Edge Protection	<input type="checkbox"/>	<input type="checkbox"/>	<input type="checkbox"/>	<input type="checkbox"/>	_____

EXERCISE MACHINES

Clear Floor Area	<input type="checkbox"/>	<input type="checkbox"/>	<input type="checkbox"/>	<input type="checkbox"/>	_____
------------------	--------------------------	--------------------------	--------------------------	--------------------------	-------

FISHING PIERS

Curbs	<input type="checkbox"/>	<input type="checkbox"/>	<input type="checkbox"/>	<input type="checkbox"/>	_____
60" Turning Space	<input type="checkbox"/>	<input type="checkbox"/>	<input type="checkbox"/>	<input type="checkbox"/>	_____

GOLF COURSES

48" Cart Path	<input type="checkbox"/>	<input type="checkbox"/>	<input type="checkbox"/>	<input type="checkbox"/>	_____
Weather Shelter	<input type="checkbox"/>	<input type="checkbox"/>	<input type="checkbox"/>	<input type="checkbox"/>	_____

PLAY AREAS

Accessible Entrance	<input type="checkbox"/>	<input type="checkbox"/>	<input type="checkbox"/>	<input checked="" type="checkbox"/>	_____
Play Equipment	<input type="checkbox"/>	<input type="checkbox"/>	<input type="checkbox"/>	<input type="checkbox"/>	_____

POOLS

Lift/Ramp _____

Shower Control _____

CHECKLIST: ADA TRANSITION PLAN FOR PUBLIC BUILDINGS

FACILITY NAME _____ FACILITY ADDRESS _____

COMPLIANCE

Total Partial Non N/A Notes

SITE

Curb Ramps _____

Parking _____

Van Parking _____

Ramps _____

Signs _____

BUILDING

Doors _____

Ramps _____

Elevators _____

Stairs _____

EW C's _____

Sinks _____

Toilets _____

Urinals _____

Signs _____

Counters



Attachment A2
PUBLIC FACILITIES SELF-EVALUATION FINDINGS

TO BE UPDATED QUARTERLY

Attachment B1: SIDEWALK DETAIL

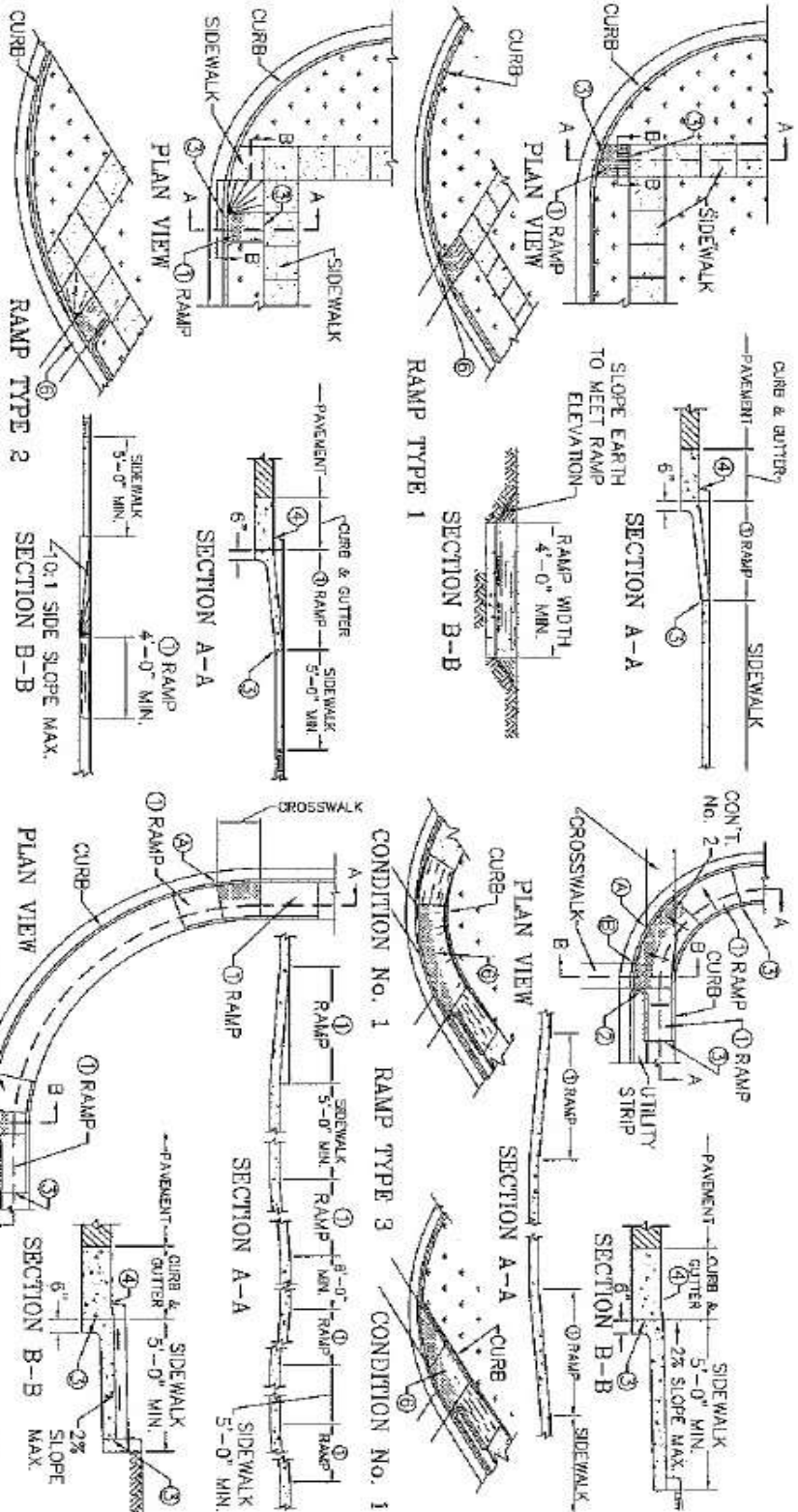

THE RAMP SHALL BE CONSTRUCTED OF CLASS "A" CONCRETE. A BROOD FINISH OR EQUAL NONSKID FINISH IS REQUIRED. DETECTABLE WARNINGS SHALL BE IDENTICAL TO SIDEWALK CONSTRUCTION. THE NORMAL GUTTER LINE SHALL BE MAINTAINED THROUGH THE AREA OF THE RAMP. RAMPS SHOULD BE LOCATED WITHIN MARKED LIMITS OF CROSSWALKS.

USE RAMP TYPE 3 WHEN POINT B IS LESS THAN 20 FEET.

USE RAMP TYPE 4 WHEN POINT B IS 20 FEET OR MORE.

① CURB RAMP GRADE SHALL NOT EXCEED 12:1. CROSS SLOPE SHALL NOT EXCEED 2% LESS THAN 4 FEET. THE AREA IS TO BE SURFACED WITH SIDEWALK WITHIN THE RAMP.

② CURB RETURN REQUIRED WHEN UTILITY STRIP IS 4 FEET OR GREATER, FOR UTILITY STRIPS LESS THAN 4 FEET, THE AREA IS TO BE SURFACED WITH SIDEWALK WITHIN THE RAMP.

③ EXPANSION JOINT AT BACK OF CURB LINE AND AT SIDEWALK LINE.

④ NO BUMP PERMITTED. SAME SLOPE AS RAMP AND NOT TO EXCEED 1" IN HEIGHT. RAMPS SHALL BE CONSTRUCTED SO THAT WATER WILL NOT ACCUMULATE ON WALKING SURFACES.

⑤ ALL SIDEWALKS REQUIRE DETECTABLE WARNINGS.

⑥ LANDINGS WILL PROVIDE A LEVEL AREA (LESS THAN 2% GRADE OR CROSS SLOPE) AT APPROXIMATE STREET ELEVATION. A 4 FOOT SQUARE LEVEL LANDING IS THE REQUIRED MINIMUM.

SIDEWALK RAMPS (PAGE 1)

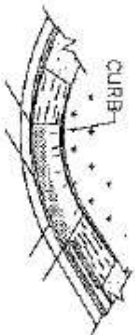
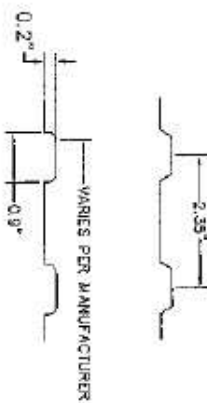
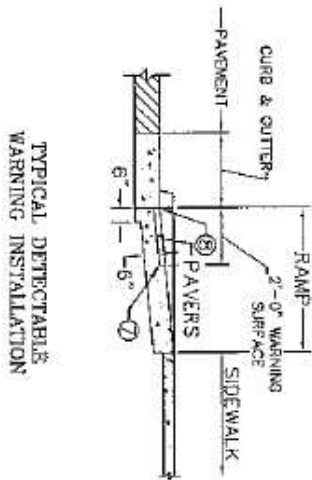
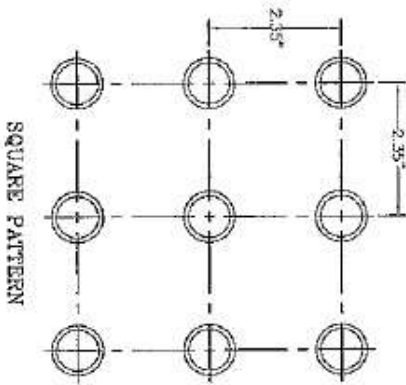
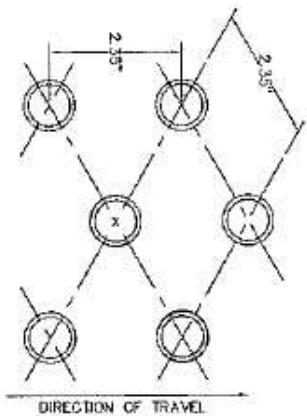
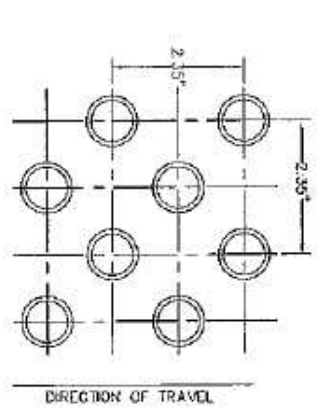
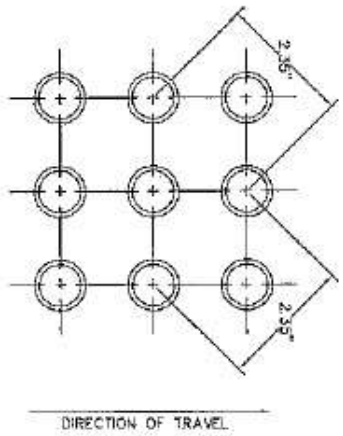

- NOTES~
1. LANDINGS WILL PROVIDE A LEVEL AREA (LESS THAN 2% GRADE OR CROSS SLOPE) AT APPROXIMATE STREET ELEVATION. A 4 FOOT SQUARE LEVEL LANDING IS THE REQUIRED MINIMUM.
 2. ALL SIDEWALK RAMPS REQUIRE DETECTABLE WARNINGS.
 3. ANY DRIVEWAY 24" OR GREATER REQUIRES ADA SIDEWALK TREATMENTS WITH DETECTABLE WARNINGS WHICH WILL BE INCIDENTAL TO THE ENTRANCE CONSTRUCTION.
 4. DETECTABLE WARNINGS SHALL BE INCIDENTAL TO SIDEWALK CONSTRUCTION. PAVERS SHALL BE CONCRETE WITH A MINIMUM THICKNESS OF 2".
 5. PAVERS SHALL BE A COLOR HOMOGENOUS THROUGHOUT THE PAYER, THAT COLOR SHALL CONTRAST VISUALLY WITH THE ADJOINING SURFACES, EITHER LIGHT-ON-DARK OR DARK-ON-LIGHT. THE DEPARTMENT WILL ALLOW EITHER YELLOW OR DARK-ON-RED COLORS.
 6. PAVERS TO BE SET IN MORTAR. DETECTABLE WARNING SURFACE BEGINS AT BACK OF CURB.

SIDEWALK RAMPS (PAGE 2)

Attachment B2
PUBLIC RIGHT-OF-WAY SELF-EVALUATION FINDINGS

TO BE UPDATED QUARTERLY

Attachment C 1: GRIEVANCE FORM



ADA Grievance Form

Please complete and sign the form and submit it within 60 calendar days

Director of Human Resources/ADA Coordinator
Boone County Administration Building
PO Box 900, 2950 Washington Street
Burlington, KY 41005

TYPE OF GRIEVANCE (Check All That Apply):

- Accommodation Request
- Program/Service
- Facility Accessibility
- Other: _____

CONTACT INFORMATION

Name _____

Address _____

City, State, Zip Code _____

Phone _____

Alternate Phone _____

Email _____

DETAILS OF COMPLAINT / INCIDENT

Date/Time of Incident _____

Facility/Location Involved _____

Describe the incident/complaint _____

(Add additional pages if necessary)

Have attempts been made to resolve the complaint through a County Department?

_____ YES _____ NO

If yes, please describe _____

8. What remedy are you seeking? _____

Signature

Date

Submit Form to: Director of Human Resources/ADA Coordinator
Boone County Administration Building
PO Box 900, 2950 Washington Street
Burlington, KY 41005
859-334-2100