

KASSON PUBLIC UTILITIES

ELECTRIC SERVICE RULES AND REGULATIONS

Revised: **March 2022**

INTRODUCTION

Kasson Public Utilities (hereafter referred to KPU) has assembled this booklet to assist its customers and their architects, engineers, or electrical contractors to plan for and obtain electric service. The requirements herein supersede all previous publications of the “Electric Service Rules and Regulations” issued by KPU prior to the above date and is subject to change without notice.

The information presented here is intended to supplement the requirements of the National Electrical Code® (NEC®), National Electric Safety Code® (NESC®), National Fuel and Gas Code (NFPA54), Liquefied Petroleum Gas Code (NFPA58), and all other applicable federal, or state, and municipal codes, regulations, laws and ordinances. It is always necessary to refer to and comply with such other codes, regulations, laws, and ordinances when planning, designing, and installing a new electrical service. Specific requirements of KPU do not intentionally conflict with any other requirements known to be in effect as of the publication date of this booklet. Any apparent conflicts of this nature should be brought to the attention of KPU for interpretation. KPU assumes no responsibility whatsoever for the manufacturer’s, supplier’s, electricians, or engineering consultant’s compliance with all applicable codes as well as all local and state codes. Any waiver at any time of KPU’s rights or privileges under the electric service rules and regulations will not be deemed a waiver as to any breach of other matter subsequently occurring.

All questions or requests should be directed to KPU’s Customer Care Department at the contact number or email address listed on page 2.

These electric rules and regulations are available for download from KPU’s website. Contact KPU for more details.

KPU ELECTRIC CONTACT INFORMATION

Main Office Address: 401 5th ST SE
Kasson, MN 55944

Web Address: www.cityofkasson.com

Contact	Phone Number	Email
Customer Care	507-634-7071	electricdept@cityofkasson.com
Electric Dept. Supervisor (desk)	507-634-6330	
Emergency Electrical Outages (24/7)	833-342-1158	
Metering Department	507-634-6330	
Modified or New Service (Utility Billing)	507-634-6325	utilitybilling@cityofkasson.com

OTHER CONTACT INFORMATION

Contact	Phone Number	Website
GOPHER STATE ONECALL	800.252.1166	www.gopherstateonecall.org

REVISION HISTORY

Revision Date	Brief Description of Revisions
Aug 2011	Starting Revision for tracking
May 2015	Major Revisions
August 2017	Revisions
March 2022	Revisions

TABLE OF CONTENTS

INTRODUCTION	1
KPU ELECTRIC CONTACT INFORMATION	2
REVISION HISTORY	3
TABLE OF CONTENTS	4
SECTION 100 – DEFINITIONS	7
SECTION 200 – GENERAL INFORMATION	13
201 SERVICE JURISDICTION	13
202 APPLICATION FOR SERVICE	13
203 OWNERSHIP OF EQUIPMENT	14
204 EASEMENTS	14
205 INSPECTION OF CUSTOMER’S FACILITIES	15
206 SERVICE CONNECTION, DISCONNECTION & RECONNECTION	16
207 LIABILITY	17
208 SERVICE INTERRUPTIONS	17
209 ACCESS	18
210 CUSTOMER RESPONSIBILITY	18
211 REVISIONS OF REQUIREMENTS	18
SECTION 300 – STANDARD SERVICES	19
301 GENERAL CHARACTERISTICS	19
302 AVAILABILITY OF SERVICE	19
303 SECONDARY SERVICE VOLTAGE	19
304 PRIMARY SERVICE VOLTAGES	20
SECTION 400 – SPECIAL SERVICES	21
401 TEMPORARY SERVICE REQUIREMENTS	21
402 SERVICES FOR UNUSUAL LOAD CHARACTERISTICS	22
403 EXCESS FACILITIES	22
404 REDUNDANT FACILITIES	22
405 IN-BUILDING TRANSFORMER VAULT INSTALLATIONS	22
406 RELOCATION OR PROTECTION OF KPU FACILITIES	23
407 REWIRING OR UPGRADING EXISTING FACILITIES	23
SECTION 500 – DISTRIBUTED ENERGY RESOURCES	25
501 GENERAL INTERCONNECTION REQUIREMENTS	25
502 TECHNICAL REQUIREMENTS	25
SECTION 600 – METERS AND METERING EQUIPMENT	26
600 GENERAL	26
601 METERING EQUIPMENT RESPONSIBILITIES	26
602 LOCATION OF METERS	26
603 GROUPED METERS	29
604 METER IDENTIFICATION	29
605 METER MOUNTING	29
606 METER CONNECTIONS	30
607 WIRING RESTRICTIONS ON METERS & METERING SETS	30
608 METER TESTING	31
609 METER SEALS	31
610 INSTRUMENT TRANSFORMER METER INSTALLATIONS	31
611 SELF-CONTAINED METER INSTALLATIONS	34

612	MASTER METERING INSTALLATIONS.....	34
613	APPROVED METER SOCKETS.....	35
614	SERVICE AT 480 VOLTS	37
615	LOCATION OF HIGH-LEG IN METER SOCKET ON 240/120 VOLT, 3-PHASE SERVICES.....	37
616	REMOVING KPU SEALS AND METERS.....	37
617	CUSTOMER GENERATION	37
618	PROPER GROUNDING/BONDING OF METER SOCKETS & SERVICES	37
619	CUSTOMER DISCONNECT SWITCH	38
620	SPECIAL SOCKETS.....	39
621	KPU OWNED EQUIPMENT	39
622	TEMPORARY REMOVAL OF CUSTOMER OWNED METER SOCKETS.....	39
623	PULSE INITIATING DEVICE.....	39
SECTION 700	– CUSTOMER UTILIZATION EQUIPMENT	41
701	PROTECTION OF CUSTOMER EQUIPMENT	41
702	MOTOR STARTING CURRENTS	42
703	POWER FACTOR	42
704	FAULT CURRENTS	43
705	WIRING ADEQUACY.....	43
706	CUSTOMER-OWNED GENERATING EQUIPMENT	43
707	CUSTOMER’S OBLIGATIONS	43
SECTION 800	– OVERHEAD SECONDARY SERVICES	45
801	MAXIMUM TRANSFORMER SIZE	45
802	SERVICE DROP CONDUCTORS.....	45
803	CLEARANCES.....	45
804	POINT OF ATTACHMENT	46
805	SERVICE ENTRANCE.....	46
SECTION 900	– UNDERGROUND SERVICES.....	47
901	NEW RESIDENTIAL DEVELOPMENTS	47
902	RESIDENTIAL UNDERGROUNDING IN OVERHEAD AREAS	47
903	UNDERGROUND SERVICE TO COMMERCIAL & INDUSTRIAL CUSTOMERS	48
904	SECONDARY CONNECTION CABINETS.....	49
905	TRANSFORMER CLEARANCES	50
906	OTHER PAD-MOUNTED EQUIPMENT CLEARANCES.....	50
907	WINTER INSTALLATION.....	50
908	INSTALLATION IN UNSUITABLE SOILS	50
909	TOTAL UNDERGROUNDING.....	51
SECTION 1000	– TRANSFORMERS AND TRANSFORMER DATA.....	52
1001	TRANSFORMERS	52
1002	GROUNDING	52
1003	SPECIAL RULES	52
1004	FAULT CURRENT.....	53
1005	ARC FLASH	54
SECTION 1100	– SUPPLEMENTAL INFORMATION	59
1101	USE OF SERVICE	59

1102 RATE SCHEDULE CLASSIFICATION 63
1103 PAYMENT 63
1104 CUSTOMER CHARGE..... 63
1105 NEW UNDERGROUND RESIDENTIAL SERVICE CONNECTION
CHARGE 64
1106 SERVICE DISCONNECTION/RECONNECTION..... 64
1107 SERVICE DEPOSIT 65
1108 SECURITY LIGHTING 65
1109 POWER FACTOR CORRECTION CALCULATION 65
SECTION 1200 – EXHIBIT DRAWINGS & INFORMATION 68

SECTION 100 – DEFINITIONS

Application for Service: The agreement or contract between KPU and the customer under which electric service is supplied and taken.

Accessible: Allowing or admitting, close approach; not guarded by locked doors, elevation, or other effective means including any portion of a temporary or permanent structure.

Approved: Acceptable to the authority having jurisdiction.

Building: A structure with roof and walls. Two (2) or more structures shall not be considered a single building merely by the existence of skyways, tunnels, common heating or cooling facilities, common garages, entry halls or elevators, or other attachments.

Cold Sequence: In a cold meter sequence, a disconnecting device is located on the line side (before) of the metering equipment.

Conduit: Standard tubular material used for mechanical protection of electrical distribution lines which may be exposed, buried beneath the surface of the ground, or encased in a building as required. (See definition for Duct).

NOTE: For the purpose of this document, the terms Conduit and Duct are used interchangeably

Connected Load: The combined manufacturer's rated capacity of all motors and other electric energy consuming devices on the customer's premises which may, at the will of the customer, be operated with the electric energy to be supplied from the service of KPU.

Contractor: Licensed individual or company who performs work on behalf of the customer or KPU.

Current Transformer (CT): An instrument transformer designed for the measurement or control of current.

Customer: Any individual, partnership, corporation, or other legal entity now being served or to be served, using the electric service of KPU at any specified location.

Customer's Service Equipment: The necessary equipment and accessories, located near the point of entrance of supply conductors to a building, which constitute the main control and means of disconnecting the supply to that building. This equipment usually consists of a circuit breaker or a switch and fuses.

Disconnection Means: A device, or group of devices, or other means by which the conductors of a circuit can be disconnected from their source of supply.

Distribution Lines: KPU's lines located along streets, alleys, highways, or easements on private property, when used or intended for use for general distribution of electric service to customers.

Distributed Energy Resource (DER): Often referred to in the past as Distributed Generation (DG) and on occasion also interchanged with the term Qualifying Facility (QF). DER are all types of generation and energy resources that can be interconnected to KPU's electric distribution system. DER technologies can include photovoltaic solar systems, wind turbines, storage batteries, or fossil fuel generators are not limited to renewable types of technologies.

Distributed Generation (DG): Distributed Energy Resources that are derived from a generation source, not from energy storage.

Duct: Standard tubular material used for mechanical protection of electrical distribution lines which may be exposed, buried beneath the surface of the ground, or encased in a building as required. (See definition for Conduit).

NOTE: For the purpose of this document, the terms Conduit and Duct are used interchangeably

Dwelling:

Dwelling Unit: One or more rooms for the use of one or more persons as a housekeeping unit with space for eating, living and sleeping, and permanent provisions for cooking and sanitation.

Multi-Family Dwelling: A building containing two or more dwelling units.

Single-Family Dwelling: A building consisting solely of one dwelling unit.

Easement: The right of use over and under the property of another, such as a right-of-way.

Electric Service: The availability of electric power and energy, regardless of whether any electric power and energy is actually used. The supplying of electric service by KPU consists of the maintaining, at the point of delivery, approximately the agreed voltage, phase and frequency by means of facilities adequate for carrying the load which KPU is thereby obligated to supply by reason of the known requirements.

Excess Facilities: Those instances where KPU provides distribution and/or metering facilities at the customer's request, in excess of the facilities KPU deems necessary to supply service to the customer.

Fault Current: The current that will flow through the system to a point where a piece or a conductor has failed, such as bare conductors touching together or a bare conductor touching a ground point.

Frost (Frozen Ground): A condition where the water contained within the ground freezes, resulting in additional difficulty and expense in excavation work.

Hot Sequence: In a hot meter sequence, there is not a disconnecting device located on the line side (before) the meter.

Individual KPU Metering: Direct measurement by KPU, using a KPU meter, of all electrical consumption of a customer supplied by the company.

Instrument Transformer: A transformer that reproduces in its secondary circuit, the voltage or current proportional to its primary circuit.

Instrument Transformer Cabinet: A cabinet installed and owned by the customer, complying with KPU's requirements, and designed for housing instrument transformers used for metering.

Junction Cabinet: A pad-mounted enclosure where underground primary cables are connected together, either by splices or separable connectors, for underground distribution systems.

Master Metering: Metering configuration where a single meter (Master meter) measures the consumption for a building, and then sub-meters on the Customer side of the Master Meter measure the consumption of individual load, loads, or groups of loads.

Meter/Meter Set: An instrument or instruments, together with auxiliary equipment for measuring the electric power and energy supplied to a customer.

National Electrical Code® (NEC®)¹: The current edition of the National Electrical Code as issued by the National Fire Protection Association (NFPA No. 70).

National Electric Safety Code® (NESC®)²: The current edition of the National Electric Safety Code as issued by the Institute of Electrical and Electronics Engineers (IEEE® C2), American National Standards Institute (ANSI® C2).

Nominal Voltage: The value, expressed in volts, which is assigned to a circuit or system for the purpose of conveniently designating its voltage class (such as 120/240V, 277/480Y, etc.). The actual voltage at which a circuit operates can vary from the nominal within a range established by ANSI C84.1. The customer is responsible for making sure that their systems are capable of operating within range B of ANSI C84.1.

Occupancy Unit: A room, office, apartment, or other space separated by walls or partitions that enclose the area, or a contiguous grouping thereof when occupied by a single customer.

¹ National Electrical Code® and NEC® are registered trademarks of the National Fire Protection Association, Inc., Quincy, MA 02269

² National Electric Safety Code® and NESC® are registered trademarks and service marks of the Institute of Electrical and Electronics Engineers, Inc. New York, NY 10017

Paved: A surface covered with a material such as stone, asphalt, or concrete designed for vehicular traffic.

Point of Delivery: The point where the electric energy first leaves the line or apparatus owned by KPU and enters the line or apparatus owned by the customer. This is not necessarily the point of location of KPU's meter.

Point of Interconnection: The location designated by KPU that the Customer must extend conduits to in order for KPU to install our facilities on customer property.

Primary Service: Any type of service with a nominal voltage greater than 600 volts.

KPU: Kasson Public Utilities

Rate Schedules: The classification of the use of electricity into categories considering the amount of power supplied and the purpose of its use.

Redistribution: The provision of unmetered electrical supply by a customer to customer's tenants or other occupant, or to any person who qualifies for unmetered service.

Redundant Facilities: Duplicate (partial or full) facilities installed at the request of the customer for the purpose of increasing reliability of the system for a particular customer.

Secondary Connection Cabinet: Cabinet required when the number and/or size of the conductors exceeds KPU's limit for terminating in a specific pad-mounted transformer. If a secondary connection cabinet is used, it will also be the location of the metering equipment.

Secondary Service: Any type of service with a nominal voltage less than or equal to 600 volts.

Secondary Terminal: The secondary side of a pad-mounted transformer, service pedestal, or vault, whichever is designated by KPU.

Series Subtractive Metering: An arrangement to measure consumption in a multiple occupancy unit building using individual KPU meters on each occupancy unit in series with one KPU master meter to measure total building consumption on the set of service entrance conductors or feeder supplying the individual occupancy units with billing for common area usage determined by company formula.

Service: The conductors and equipment for delivering energy from KPU's system to the wiring system of the customer.

Service Drop: The overhead service conductors from the last pole or other aerial support up to, and including the splices (if any), connecting to the service-entrance conductors at the building or other structure.

Service Entrance Conductors, Overhead System: The service conductors between the terminals of the service equipment and a point usually outside the building, clear of building walls, where joined by tap or splice to the service drop.

Service Entrance Conductors, Underground System: The service conductors between the terminals of the service equipment and the point of delivery.

Service Equipment: The necessary equipment, usually consisting of a circuit breaker or switch and fuses, and their accessories, located near the point of entrance of supply conductors to a building or other structure, or an otherwise defined area, and intended to constitute the main control and means of cutoff of the supply.

Service Upgrade: An electric service is considered upgraded if any of the following conditions are met:

- If the rating of the customer disconnect is increased
- If the main service disconnect type is changed (i.e., from fuses to a circuit breaker)
- If either the conductors between the meter socket and the customer disconnect or the conductors on the supply side of the meter are changed
- A new DER system is installed by the customer

Sub-metering: The provision of metered electrical supply through a customer owned meter to a customer's tenants, cooperative or condominium owners, other occupants, or to a portion of the customer's own electrical consumption.

Underground Residential Distribution (URD) Areas: Those residential subdivisions, or other specified areas, within which all customers are served by underground distribution lines.

Underground Service Lateral: The secondary service conductors from KPU's distribution system.

Unsuitable Backfill Material: Includes, but is not limited to, the following materials:

- Granular material (individual stones, soil in clumps or clods, etc.) larger than 1/4" in diameter
- Frozen materials
- Materials removed as rock excavation or over-excavation
- Trash, metal, or construction waste
- Environmentally contaminated soils

Utility: For the purpose of this document any public, city, or city-franchised organization that furnishes electric service.

Voltage to Ground: For grounded circuits, the voltage between the given conductor and that point or conductor of the circuit that is grounded; for underground circuits, the greatest voltage between the given conductor and any other conductor of the circuit.

Voltage Transformer (VT): An instrument transformer intended for use in the measurement or control of a circuit and designed to have its primary winding connected in parallel with the circuit.

SECTION 200 – GENERAL INFORMATION

201 SERVICE JURISDICTION

KPU has been established by the City of Kasson for the purpose of providing electricity to the residents of the City. Service will be provided to all eligible applicants only when all applications, agreements, easements, deposits, payments, and other required information have been provided to KPU.

202 APPLICATIONS FOR SERVICE

Application for initial, additional, or temporary electric service must be made by the customer, or a designated representative, to KPU. Applications can be made at KPU's Service Center or by contacting a Modified or New Service Representative (refer to page 2 for contact information). At the time of application, the customer will be required to provide, in writing on the form(s) provided, information relating to the service request, including the following:

- (1) Exact location of premises to be served, including building street address, apartment or unit number if applicable, lot and block numbers, and name of subdivision
- (2) The type of service desired (e.g., temporary, permanent, residential subdivision, dwelling unit, commercial, industrial, rewire, etc.)
- (3) The approximate date that electric service is required
- (4) The name, address, and telephone number of the customer's designated representative who will be responsible for working with KPU representatives in providing the electric service (e.g., customer, employee, engineer, contractor, etc.)
- (5) Commercial Services:
 - a) Load Data Sheet: The customer, or their representative, shall submit to KPU's Engineering Department a completed Electrical Load Data sheet specifying the type of service required by the customer and expected magnitudes of connected and peak load. Additional data in the form of construction drawings and the proposed service entrance may also be necessary for KPU to adequately determine the capacity and arrangement of service to the customer. The completed Load Data sheet must be received before KPU can perform the necessary planning and design of the project. Failure to provide this information at the start of a project may result in significant delay in KPU being able to provide service
 - b) The Commercial Service Application must be submitted as soon as feasible in order for KPU to establish an account, and allow adequate time to invoice and receive payment for the Line Extension Fee, if applicable

- c) Notification to KPU Engineering that the customer is ready for installation of the transformer must be received a minimum of ten (10) working days prior to energizing the service

KPU should be advised of planning installations as early as possible so that details for furnishing service may be arranged and construction completed by the desired date. Application forms and additional information may be obtained at www.cityofkasson.com under the Electric Department tab. Contact a KPU Modified or New Service Representative (refer to page 2 for contact information) with questions concerning the application process.

203 OWNERSHIP OF EQUIPMENT

203.1 KPU-Owned Equipment - The meter and associated metering equipment furnished or installed by KPU are the property of KPU.

- (1) Overhead Service – In addition to the metering equipment, the overhead service drop installed by KPU is the property of KPU
- (2) Underground Service – In addition to the metering equipment, all equipment up to and including the designated point of delivery is the property of KPU

203.2 Customer-Owned Equipment - The meter socket, instrument transformer compartment (if required, see Section 610), the service entrance conductors and conduit from the meter socket to the service entrance disconnect, the service entrance switch or circuit breaker, the service entrance ground equipment, and the concrete transformer pad and grounding grid are the property of the customer.

- (1) Overhead Service – In addition to the equipment on the customer side of the meter socket, the service drop wire holder or bracket, the weather head, and either the service mast and conduit with entrance wires, or the service entrance cable with watertight connection to the meter socket are the property of the customer
- (2) Underground Service – In addition to the equipment on the customer side of the meter, all conduit and cable required to extend the secondary service lateral from KPU's point of delivery to the meter socket are the property of the customer

203.3 Responsibilities - The customer and KPU are responsible for the installation, maintenance, repair, and replacement of the electric service equipment which each owns.

204 EASEMENTS

Whenever any KPU-owned underground and/or overhead material and equipment is located above or below the customer's property, the customer shall grant an easement to KPU to the extent which KPU deems necessary. All utility easements required by KPU are to be granted by the customer at no cost to KPU.

204.1 Easement Legal Description and Exhibit Processes

- (1) Kasson Community Development – When the easement is sought during the Kasson Community Development process, the customer or property developer shall provide the legal description and exhibit by a Registered Land Surveyor
- (2) Other Easement Request – When the easement is sought after the property has been developed, KPU will provide an electronic copy of the assembled easement (legal description and exhibit by a Registered Land Surveyor) for the property owner's signature. Once sign-off by the property owner is received by KPU, KPU will record the signed easement paperwork
- (3) Where no formal Utility easement exists on the recorded plat but electric service exists and has existed, whether overhead or underground and for the express purpose of supplying electric service to the property and/or customer, an implied easement is assumed by the City of Kasson to have existed and be currently existing.

204.2 Change of Grade - The finished grade in any platted or recorded utility easement shall not be altered without first contacting KPU Engineering to determine if electric facilities are installed within the easement. Permission may be granted to change the finished grade by KPU Engineering if the proposed grade change will not affect minimum burial depth requirements for ducts or require removal and reinstallation of above grade facilities such as transformers, poles, secondary pedestals, etc. Replacement and/or relocation of KPU facilities, at customer's expense, may be required if necessitated by the proposed grade change. KPU Engineering will provide a cost estimate for all work associated with the proposed grade change for approval prior to the commencement of any proposed grade change work. Payment must be received and cleared prior to the start of any work by KPU.

205 INSPECTION OF CUSTOMER'S FACILITIES

205.1 Requirements – As a minimum, wiring and electrical equipment of the customer shall be installed in accordance with the latest edition of the National Electrical Code®.

205.2 Inside City Limits – Customer services and associated wiring installations located within the Kasson city limits, including temporary installations, must be inspected and approved by an authorized inspector of the City Building Safety

Department as required by Minnesota Statutes Section 326.B.36. KPU will make connection only after approval by the authorized inspecting authority. The inspector is required by Minnesota Statutes Section 326.B.36 to disconnect or have disconnected by the utility any installation that is declared by the inspector to be unsafe and a hazard.

205.4 Disconnected Service Inspection – For any electric service that has been disconnected for more than ninety (90) days prior to a reconnection request, the customer will be required to hire a licensed electrical contractor to perform an inspection of the building or dwelling’s electrical wiring to verify that no unsafe or hazardous conditions are present prior to KPU re-energizing the service.

Exception:

Multi-family dwellings that have 6 meters or more installed, with at least one (1) meter in the ganged service entrance energized, are exempt from the above requirement

205.5 Other Required Inspections

- (1) Transformer Pad – Prior to pouring concrete, the customer, or customer’s contractor, shall complete and submit to KPU’s Engineering Department the completed “Request for Transformer Pad Inspection” form, with multiple photos. KPU personnel will review the photos and visually inspect the formed pad within the timeframe noted on the form. Observed deficiencies will be communicated to the contact listed on the submitted inspection form. **Corrections and re-inspection by KPU personnel must be made before approval to pour concrete will be given.** KPU reserves the right to refuse service if the transformer pad is poured prior to inspection and correction of noted deficiencies
- (2) Subdivision Installation – The customer, or customer’s contractor, shall complete and submit plans to Kasson Planning and Zoning. The site will then be inspected for compliance with requirements. If no deficiencies are found, the site will be scheduled for joint utility installation. If any deficiencies are found, corrections must be made and inspected prior to the site being scheduled for joint utility installation.

206 SERVICE CONNECTION, DISCONNECTION & RECONNECTION

206.1 Site Readiness – After the customer’s installation has been inspected and approved by the proper authority, a meter will be installed by KPU and the electric service made available provided that all applications, fees, agreements, and deposits have been submitted by the customer and approved by KPU. Inspection notices must be received by KPU two (2) business days prior to the date that the connection is desired. NO connections will be made on weekends

or holidays. Under special circumstances, verbal inspections will be accepted as long as written inspection documentation is submitted immediately thereafter.

206.2 Notification – Customer requests for disconnection or reconnection of existing services must be received by KPU two (2) business days prior to the desired time of disconnection or reconnection (weekends and holidays excluded). For the mutual protection of the customer and KPU, only authorized employees of KPU are permitted to set and remove meters, or to make and energize or break and de-energize the connection between KPU’s service drop or secondary terminals and the customer’s service entrance conductors or underground service laterals.

206.3 Building Demolition – If a building is scheduled for demolition, the contractor shall notify KPU’s New Services Department for a service disconnect a minimum of two (2) business days prior to the start of demolition. KPU will then issue a work order to disconnect the service. There is no KPU charge for the retirement of electric service.

If at some future time the owner at the location requires service, the owner shall be required to submit a new “APPLICATION FOR SERVICE” request, pay any and all liens or amounts encumbered by KPU and/or any outstanding KPU charges before an account will be reactivated.

206.4 Commercial Customer Requested Outage – Customer shall contact the City of Kasson Electric Dept. at 507-634-6330 a minimum of 2 days prior to requested outage. Individual cases necessitating scheduled weekend, evening or holiday outages will need prior additional approval from the Public Works Director. Compensation for related employee overtime may be requested and paid PRIOR to any work being completed.

207 LIABILITY

207.1 Damage as Result of Service – KPU does not engage in the practice of doing interior wiring on the customer’s premises except for the installation and maintenance of its own property, and therefore, is not responsible for service beyond the point of delivery. KPU shall not be liable for damage to any customer or to any third party resulting from the use of the service or from the presence of KPU appliances or equipment on the customer’s premises.

207.2 Responsibility – The customer is solely responsible for any accidents, fires, or failures resulting from the condition and use of his wiring installation or equipment.

208 SERVICE INTERRUPTIONS

208.1 Notice – KPU reserves the right to interrupt service at any time. Interruptions for maintenance and system improvements will be prearranged and advance notice will be given to the customer whenever practical.

208.2 Responsibility – KPU will not be responsible for consequential damages resulting from service interruptions or fluctuations outside its control or from operations in response to abnormal system conditions. Customers requiring service reliability and/or stability exceeding KPU’s normal service should consider uninterruptible power supplies, isolation transformers, power conditioners, redundant services, or other options to provide the level of service needed. KPU’s Engineering Department is available to discuss such needs.

209 ACCESS

Employees of KPU shall have the right of access to the customer’s premises at all reasonable times for the purpose of installing, reading, inspecting, maintaining, or removing any of its meters, devices, or other equipment which is used in connection with the furnishing of the customer’s electric service.

210 CUSTOMER RESPONSIBILITY

Failure of the Customer to notify KPU in a timely manner of any planned alteration to electric service facilities or increased electrical load, and failure to comply with KPU’s published rules, regulations, and rate schedules may result in delayed connections, interruption of service, or damage to equipment, for which KPU disclaims all responsibility.

211 REVISIONS OF REQUIREMENTS

All requirements stated or implied herein are subject to change at any time without prior notice.

SECTION 300 – STANDARD SERVICES

301 GENERAL CHARACTERISTICS

This section describes the types of services offered to customers under KPU's standard rate schedules. Electric service supplied by KPU is alternating current having a nominal frequency of 60 Hertz (cycles per second).

302 AVAILABILITY OF SERVICE

Although the types of service listed in subsequent sections are generally available through the area served by KPU, service of the type requested by a customer may not be available at the location where such service is desired, and in certain cases may be available only through special contractual arrangements and at the expense of the customer. Each customer will generally be allowed only one type of service and one point of delivery for each location.

302.1 Redundant Services – Refer to Section 404 for requirements.

302.2 Multiple Services – Only one (1) service installation to a customer's service equipment is allowed. During customer renovation or service upgrade work, should KPU determine that a customer's service equipment has multiple services connected to it, KPU Engineering will work with the customer to eliminate the multiple service installation as soon as possible.

303 SECONDARY SERVICE VOLTAGE

The following types of secondary service are generally available to customers served under KPU's standard rate schedules:

303.1 Single Phase Service – 120/240 Volt, 3-Wire, Grounded Neutral: Generally available where the total load is 100 kVA or less for pad-mount service, or 50 kVA or less for pole-mounted service, with an underground secondary in each case

303.2 Three Phase Service – Generally available where facilities of adequate capacity are adjacent to the premises to be served

- (1) 208Y/120 Volt, 4-Wire, Grounded Neutral: Generally available to customers with loads determined by KPU to be 75 kVA or greater for pad-mount service, or 45 kVA or greater for pole-mounted service with an underground secondary in each case. The maximum size pad-mounted transformer that KPU will install for this service voltage is 1000 kVA
- (2) 240/120 Volt, Delta, 4-Wire, Grounded Neutral: **No longer available as a new standard service**

- (3) 240 Volt (and 480 Volt), Delta, 3-Wire: **No longer available as a new standard service**
- (4) 480Y/277 Volt, 4-Wire, Grounded Neutral: Generally available to customers with loads determined by KPU to be 75 kVA or greater for pad-mount service, or 45 kVA or greater for pole-mounted service with an underground secondary in each case. The maximum size pad-mounted transformer that KPU will install is 2500 kVA

303.3 New Development Cost Calculation – Refer to KPU Line Extension Policy. Any costs assessed to the project by KPU will need to be paid by the customer prior to KPU performing facility installation.

303.4 Redevelopment Cost Calculation – Contact KPU's Engineering Department for determination of cost (if any) that will be assessed to the project by KPU.

304 PRIMARY SERVICE VOLTAGES

Three-Phase, 12470Y/7200 Volt, 4-Wire, Grounded Neutral Service: Available only by special request where the total annual peak load at one site is projected by KPU to exceed 500 kW. KPU reserves the right to deny a request for a primary voltage service. Where provided, the point of delivery will normally be the terminals of KPU's cable in the customer's switchgear.

SECTION 400 – SPECIAL SERVICES

401 TEMPORARY SERVICE REQUIREMENTS

401.1 General – Temporary service is intended to be supplied at secondary voltages only to customers for use during the construction of permanent facilities and before the permanent service can be installed.

401.2 Address – The address of the location to be supplied with temporary service must be permanently displayed at the location and on the temporary pedestal/meter location and be easily readable from the street before KPU will install the temporary service. All overhead and underground temporary services will be metered and billed under one of KPU's standard rate schedules.

401.3 Installation – The customer shall provide an approved meter socket with the necessary raceway and a suitable rigid support for attachment of the metering equipment and service drop. On all three phase temporary services, where required, the customer shall also provide a suitable enclosure for installation of KPU's instrument transformers.

401.4 Installation Length – Service to any electrical installation for a period of less than two (2) years shall be considered as "temporary service". Any installation that remains in service longer than this timeframe must be changed to a permanent service installation when directed by KPU.

401.5 Fees - Temporary electrical services costs shall be in accordance with the following requirements listed below:

- (1) Secondary Available at Property:
 - a) A temporary meter installation fee will be assessed for the first single phase temporary service installed for construction. The location of the temporary service will be designated by KPU
- (2) KPU has primary voltage facilities available on or adjacent to the lot and setting of a transformer is required:
 - a) A temporary meter installation fee and a temporary facilities installation fee will be assessed for the first temporary service installed for construction. The location of the temporary service will be designated by KPU
- (3) KPU does not have adequate facilities in the area:
 - a) The customer will be required to pay KPU for the actual cost to install and remove the temporary service(s)

(4) KPU may require temporary service fees to be paid in advance.

402 SERVICES FOR UNUSUAL LOAD CHARACTERISTICS

402.1 Customer Transients – The operation of customer equipment having a relatively high load of short or intermittent duration, such as welders, compressor motors, elevators, and X-ray equipment, may cause serious fluctuations of voltage and interfere with the service being provided by KPU to other customers. If such a load is anticipated, the customer must consult with KPU and agree to install such protective devices as may be required so as not to cause damage to any of KPU's equipment or in any way inhibit service to other customers.

402.2 Special Compensation - Special compensation may be required by KPU, from the customer, in those cases where it is necessary for KPU to install non-standard, or larger, facilities than would normally be required to provide satisfactory service. (Refer to Section 700 for additional details).

403 EXCESS FACILITIES

KPU will size utility electric facilities (primary cable and transformer) to serve the load projected by KPU. If a customer desires KPU to install excess facilities, KPU must be advised as soon as possible so the feasibility of such a service can be determined. If KPU determines that excess facilities can and will be provided, the customer will be required to reimburse KPU for the difference in cost between the standard service and the excess facilities, including all labor, materials, and overheads. A written agreement between the customer and KPU shall also be executed at KPU's discretion.

404 REDUNDANT FACILITIES

KPU will provide one set of facilities (such as a set of primary cables and a transformer) to one point of service for each customer. If a customer requires redundant facilities (more than one set of facilities to the same point of service), KPU must be advised as soon as possible so the feasibility of such service can be determined. If KPU determines that redundant facilities can and will be provided, the customer will be required to reimburse KPU for the entire cost of additional facilities, including all labor, materials, vehicle charges, and overheads. An agreement between the customer and KPU may also be executed at KPU's discretion.

405 IN-BUILDING TRANSFORMER VAULT INSTALLATIONS

405.1 Availability –Additional fees and agreements between the customer and KPU will be required for this type of transformer installation. KPU reserves the right to refuse service to this type of installation.

406 RELOCATION OR PROTECTION OF KPU FACILITIES

406.1 Responsibilities – It is the responsibility of the customer to arrange for the relocation and/or protection of KPU's facilities whenever such action is appropriate. Any intended relocation or protection of KPU's facilities must be reviewed with and approved by KPU in advance.

406.2 Customer Costs – The cost of any change or relocation of KPU's facilities for the benefit only of the customer, and which has been initiated by the customer, shall be borne solely by the customer. A deposit by the customer may also be required before the changes are made.

406.3 KPU Costs – KPU will bear costs to the extent that a change or relocation benefits KPU. The customer shall not be required to pay for changes necessitated through public improvements by the City, County or State.

406.4 Painting – The customer shall not paint or otherwise modify the appearance of any KPU owned equipment or facilities.

407 REWIRING OR UPGRADING EXISTING FACILITIES

407.1 General – The customer or electrical contractor shall contact KPU when it is necessary to rewire or upgrade an existing electric service. All KPU Electric Service Rules & Regulations must be followed. The customer shall be responsible for maintaining the same phase rotation for 3-phase rewires.

407.2 Not Permitted – Customers shall not be allowed to convert an existing underground electric service to an overhead service.

407.3 Conversion of Overhead Facilities – Customer-initiated service work that necessitates any change in the existing overhead wire size shall be required to move to an underground service. (**Ex: Upgrading a service size from 60A to a 200A panel**). KPU will provide either 1/0 or 4/0 URD triplex conductor from the meter installation on the house to KPU's point of service as designated by a KPU representative. Customer will pay all associated additional labor charges to their licensed electrician. Customer owns wire upon completion as indicated above (refer to 203.2 / 203.3) and below (refer to 407.5).

407.4 Meter Socket location - Meter sockets shall only be attached to the exterior of a building or house (or if approved by KPU a remote customer owned site) in a location accessible at all times by KPU personal. Any service work initiated by the customer shall relocate the meter from inside a structure or attached to a KPU pole to the exterior of that structure as explained above. (Refer to Section 600 for meter requirements)

407.5 Underground Service – All underground services from the point of attachment to KPU's service point (pedestal, transformer, etc.) are the owned by

the customer. Repair, replacement or upgrades due to changes in load requirements are the responsibility of the owner. (Refer to 203.2 & 203.3)

SECTION 500 – DISTRIBUTED ENERGY RESOURCES

501 GENERAL INTERCONNECTION REQUIREMENTS

The State of Minnesota has interconnection process standards in effect to address interconnection of distributed energy resources (DER) to the distribution grid. Kasson Public Utilities has process and technical requirements that meet the State standards. The customer shall follow KPU's process for projects to install, modify existing, and operate generating equipment interconnected with KPU's distribution system. No generation equipment shall be allowed to operate interconnected to KPU's distribution system without prior approval from KPU and meeting all requirements of KPU, the State of Minnesota, and all other applicable regulations and standards.

502 TECHNICAL REQUIREMENTS

A copy of KPU's rules, technical requirements, process documentation, and applications for operation of Distributed Energy Resources are available through KPU's website www.cityofkasson.com (look for the NOVA Portal). If the DER is under 10 MW in size, it will follow the appropriate State of MN mandated process. If the DER size is over 10 MW, contact KPU's Engineering Department for guidance prior to starting design.

SECTION 600 – METERS AND METERING EQUIPMENT

600 GENERAL

This section covers the installation of meters and associated equipment such as current and potential transformers for both overhead and underground services. Further description of KPU requirements for both overhead and underground services is covered in other sections of this booklet. The requirements contained in this section are for services rated 600 volts or less. When services are required at primary voltage (such as 12470Y/7200 volts), the metering requirements and equipment will be determined on an individual basis.

601 METERING EQUIPMENT RESPONSIBILITIES

All metering equipment, with the exception of the meter, current and potential transformers, must be purchased and installed by the customer or electrical contractor. All metering equipment installed must be certified and labeled and have prior approval of KPU's Electric Metering Department. Metering equipment installed without KPU approval will not be energized unless special permission from KPU's Electric Metering Department is obtained. KPU will energize only one (1) set of metering equipment under each contract or application for one class of service.

602 LOCATION OF METERS

602.1 General – Meter locations will be agreed upon by representatives of the customer and KPU, subject to final approval by KPU.

602.2 Clearances – Meters shall be installed in a location with not less than three (3) feet of unobstructed space in front and 30 inches total in width. Meters shall not be located where they are subject to corrosive fumes, dust, vibration or physical damage. Outdoor meters shall not be located in carports, under porches whether open or enclosed, or along walkways or driveways where they might create a hazard to people or be subject to damage by passing objects. Required meter working and safety clearances are shown in Section 1200, Exhibit 11.1.

602.3 Accessibility – Meter locations shall not be hazardous or cause inconvenience to employees of KPU when installing, maintaining, or reading the meters. KPU personnel shall have direct and unobstructed access to KPU's metering equipment at all times. Recessed meter socket installations shall not be permitted.

602.4 Height Limits - All meters located outdoors on residential, industrial, or commercial services, where the meter is mounted on a permanent structure, shall have a maximum installation height of 5'-0" and a minimum installation

height of 3'-0" from final grade to the center of the meter. A typical residential underground service meter installation is shown in Section 1200, Exhibit 1.

602.5 Residential – Residential meter installations shall comply with the following requirements:

- (1) All new services must have the electric meter located outside
- (2) Existing residential customers where the meter is located inside shall relocate the meter to the outside during a service upgrade as defined under Section 100 Definitions
- (3) Any service upgrade or DER installation requires the existing meter socket to be changed to an approved self-contained lever bypass type (if non-compliant). DER installation shall also require that a separate lever bypass meter socket for a KPU production meter to be installed. Production meter information is for KPU's use only.
- (4) All new self-contained meter sockets installed under (1), (2), or (3) above must be on the list of approved meter sockets (refer to Section 613)

602.6 Multi-Family Dwelling – Where more than one meter is installed (typical for apartment complexes), meters shall be grouped outdoors at a point accessible at all times to each customer and to KPU personnel.

Exceptions:

- a) *Multi-family dwellings that have 24 meters or more may request to locate the meters inside as long as they are grouped at one (1) location and accessible at all times to each customer and to KPU personnel*
- b) *Multi-family dwellings where the building has over three (3) occupied stories fully above grade, the customer may request in writing for permission to be allowed to install grouped metering panels in multiple locations. The metering locations should be minimized and typically would only be allowed on every 3rd story of the building*

In all cases where multi-metering panels with stacked meter sockets are used, the maximum height to the center of the top meter shall be not more than 6'-0" indoors and 5'-0" outdoors and the minimum height to the center of the bottom meter shall be not less 1'-0" indoors and 3'-0" outdoors. Individual apartment disconnects must be connected on the load side of the meter. If the service voltage is 120/208 volts, a fifth terminal located at the 9 o'clock position is required in the socket and must be connected to the service neutral in accordance with the National Electric Code® (Refer to Section 1200, Exhibit 11.0). The house meter socket for apartment buildings requires an approved lever actuated positive bypass mechanism which will provide clamping pressure on the meter blades. Only one (1) meter may be installed under one socket cover in multi-metering panels

KPU will set a minimum of one floor of meters at a time. Meter service charges will start at the time of the meter set.

602.7 Mobile Homes - KPU will individually meter each mobile home located in a mobile home court or addition to a mobile home court. Resale of metered electrical energy by the court owner will not be permitted in these facilities. Individual meter pedestals, with bypass sockets, shall be provided by the customer or his representative. Maintenance and repair of the meter pedestal is the responsibility of the customer. A typical mobile home metering arrangement is shown in Section 1200, Exhibit 2.

602.8 Industrial and Commercial – Industrial and Commercial self-contained meter installations shall comply with the following requirements:

- (1) All new services must comply with the requirements of Sections 602.1 through 602.4 listed above
- (2) Any service upgrade or DER installation requires the existing meter socket to be changed to an approved self-contained lever bypass type (if non-compliant)
- (3) All new self-contained meter sockets installed must be on the list of approved meter sockets (refer to Section 613)

602.9 Commercial Multi-Metering Panels – Installations shall comply with the following requirements:

- (1) All commercial multi-metering panels used in shopping centers, spec. buildings, and multi-commercial tenant buildings shall have a maximum of four (4) meter sockets per vertical stack. In all cases, the maximum height to the center of the top meter shall be not more than 6'-0" indoors and 5'-0" outdoors and the minimum height to the center of the bottom meter shall be not less 1'-0" indoors and 3'-0" outdoors. An approved lever bypass is required on all meter sockets and each individual unit disconnect shall only be connected to the load side of the meter. Each individual meter socket shall have a barrier to isolate the customer's disconnect switch and wiring from the metering area. Only one (1) meter may be installed under one socket cover. A system neutral is required to each 5 and 7 terminal meter socket in accordance with the National Electric Code®
- (2) Each meter shall have a separate accessible lockable service disconnect wired in cold sequence to be used by KPU

Exception:

In situations where the building has over three (3) occupied stories fully above grade, the customer may request in writing for permission to be allowed to install

grouped metering panels in multiple locations. The metering locations should be minimized and typically would only be allowed on every 3rd story of the building

603 GROUPED METERS

In installations requiring more than one meter, the meters shall be grouped and suitably connected such that a meter serves no more than one customer. The height limits stated previously also pertain to grouped meters where practicable. If deemed necessary by the space available, the meters may be stacked in an orderly fashion. Any dwelling with more than one customer living therein must have an individual meter for each dwelling unit. These meters must be easily accessible to all tenants and to KPU personnel. There shall be an approved type of disconnecting means for each meter, which is lockable in some way to prevent reconnection by other than KPU personnel. A typical multiple metering arrangement is shown in Section 1200, Exhibit 3.

604 METER IDENTIFICATION

604.1 Requirements – If more than one meter is required for a building, each meter socket shall be identified and permanently designated in a suitable manner indicating the particular customer served. An engraved hard plastic tag will be required with ½ inch block letters or numbers. The tag shall be securely attached to the exterior, non-removable portion of the meter socket and at the individual meter main disconnect. Any other means of identification is not acceptable.

Meters will not be installed until the above requirements are met.

604.2 Circuit Checking – Each circuit shall be carefully traced and rechecked by the customer or contractor to ensure against errors in wiring that would result in one customer obtaining service through the meter serving another customer. This is especially important when the wiring is concealed. Electric service shall not be energized if meter sockets are not identified. It will be the contractor's/owner's responsibility to correct any errors due to misidentification of meter sockets. KPU reserves the right to charge the building owner and/or electrical contractor for actual costs incurred by KPU to make corrections.

605 METER MOUNTING

605.1 Outdoor Meters and Meter Mounting Devices – Outdoor meters and meter mounting devices shall be mounted securely on permanent structures such as houses, garages, and other buildings. Where outdoor meters are installed on surfaces that prevent installation of the meter-mounting device in an exact vertical plane, a meter board must be installed or the surface modified in such a manner that the meter-mounting device can be installed vertically.

605.2 Preferred Meter Location(s) – The preferred meter location is within ten (10) feet of the front end of the building (house or attached garage) on a single-family dwelling for new customer hook ups. All meter locations for rewired or upgraded services shall be located outdoors with locations agreed upon between

customer, contractor, and KPU personnel with final approval by KPU personnel. KPU has the right to refuse to energize service if these requirements have not been met.

605.3 Indoor Meter Location(s) – Indoor meters, where permitted, shall be mounted in accordance with the preceding requirements of this section and shall be located as close as possible to the point where service enters the building. Indoor metering equipment shall be mounted securely in a vertical plane on permanent structures in a location free from moisture, high temperature, vibration, dust, or dirt. KPU generally does NOT allow indoor metering. Please contact a KPU Electric Dept. Representative.

606 METER CONNECTIONS

606.1 General – The customer shall provide the necessary wiring for the meter set with the wiring so arranged that the line (supply) side can be connected to the top terminals of the socket and the load side to the bottom terminals. All conductors shall extend into the meter socket and shall be of equal length and at a minimum distance equal to the length of the socket trough. All neutral conductors must be insulated.

606.2 Underground Services – Underground service installations shall comply with the following requirements:

- (1) Line side neutral wire shall be identified in accordance with the National Electrical Code®
- (2) An expansion joint shall be furnished and installed by the customer on all new underground residential meter installations. The expansion joint shall be a minimum eighteen (18) inch length Schedule 80 PVC installed at the bottom of the meter housing
- (3) Sufficient slack should be left in the underground cables to make up for any ground shifting due to settling or extreme cold

607 WIRING RESTRICTIONS ON METERS & METERING SETS

607.1 General – Meters and metering sets shall comply with the following requirements:

- (1) No customer wiring shall be permitted to be connected to the metering, secondary wiring, or under the terminals of the meter
- (2) No part of the metering set shall be used as a junction box for the customer's wiring
- (3) No non-KPU owned equipment shall be permitted to be installed between the self-contained meter and the customer-owned meter socket.

608 METER TESTING

608.1 Testing Request – Any customer, who believes that a meter is failing to register properly the use of electricity, may request a meter check by contacting an KPU Electric Dept. Representative. KPU will test the meter using standard calibration equipment and generally accepted test procedures within a reasonable period of time. Customers who request additional meter tests within a twelve (12) month period may be charged for the additional tests at a standard fee.

608.2 Meter Error Standard – Whenever a watt-hour meter is found upon test to have an average error of more than two percent (2%) from one hundred percent (100%) or a demand meter more than one and one-half percent (1.5%) from one hundred percent (100%), a recalculation of bills for service will be made on the basis that the meter should be one hundred percent (100%) accurate with respect to a working test standard.

608.3 Meter Inaccuracy (Working) – If the period of inaccuracy cannot be determined, it will be assumed that the metering equipment has become inaccurate at a uniform rate since it was installed or last tested unless there is a valid reason to use another method. Recalculation of bills is based upon KPU Utility Billing best practices.

608.4 Meter Inaccuracy (Failure) – When the average error cannot be determined by test due to complete failure of all or part of the metering equipment, then an estimate of the quantity of energy consumed based upon available data will be used to determine the adjusted bills.

609 METER SEALS

All connections to KPU service equipment shall be made by KPU Electric Metering Department personnel only. Unauthorized connections to or tampering with any KPU meter, associated equipment or meter seals, or indications or evidence thereof subjects the customer to immediate discontinuance of service, prosecution under the laws of Minnesota, adjustment of prior bills for services rendered, and reimbursement to KPU for all extra expense incurred on the account. In addition, when the unauthorized connections or tampering involve an inside meter, the customer shall, at his own expense, relocate all service equipment and metering facilities outside the building.

610 INSTRUMENT TRANSFORMER METER INSTALLATIONS

KPU no longer furnishes instrument rated meter sockets. Please contact a local electrical distributor of your choice to purchase an KPU approved instrument rated meter socket. If requiring an 8 terminal meter socket, please contact KPU's Electric Metering Department for prior approval.

610.1 Where Required – It will be necessary for KPU to use instrument transformers in the metering installation under the conditions listed below:

- (1) Single Phase Service: When any single phase service exceeds 320 continuous amps in size or exceeds 240 volts
- (2) Three Phase Service: When any three phase service exceeds 320 continuous amps in size or exceeds 240 volts

610.2 Instrument Transformer Provision & Location – All instrument transformers will be furnished by KPU and installed by KPU's Electric Metering Department, or delivered to the customer/contractor to install into an approved instrument transformer cabinet. The instrument transformer cabinet will be located before the customer service entrance disconnect switch.

610.3 Secondary Metering Instrument Transformer Cabinet Requirements – Cabinet shall be furnished and installed by the customer. This includes all services, either overhead or underground. All cabinets must be certified and labeled, approved by KPU personnel and meet all National Electric Code® requirements prior to installation. All cabinets must conform to the following:

- (1) The meter socket shall not be mounted to the door of the cabinet
- (2) Cabinets must be UL approved and be the correct NEMA class for the area environment in which it is installed
- (3) Minimum instrument transformer cabinet sizes are as follows:
 - a) 250 volts and below: 48 inches high, 25 inches wide, and 15 inches deep
 - b) 251 – 600 volts: 48 inches high, 36 inches wide, and 15 inches deep
- (4) The door must have a single closure with provisions for locking with a standard padlock through the handle
- (5) Cabinet must be hinged on the right or left side only
- (6) Cabinet shall not be used as a junction box or service connection cabinet
- (7) Only KPU metering transformers may be contained therein
- (8) A 1-inch conduit installed between the cabinet and meter socket location is required
- (9) Cabinet must accept bar-type current transformers on all services 1200 amps or less
- (10) Customer is required to label the line side and load side of the conductors within the instrument transformer cabinet

610.4 New Service Secondary Metering Requirements – For any new electrical services requiring the use of instrument transformers, the instrument

transformers must be mounted in an approved instrument transformer cabinet complying with the requirements of 610.3 above and be located as follows:

- (1) **Underground Service from Pad-Mounted Transformers:** When service is supplied underground from a pad-mounted transformer, the location of the instrument transformer cabinet must be approved by KPU during installation
- (2) **Overhead Services:** When service is provided by overhead service drops, approved outdoor instrument transformer cabinets will be required. Location of transformer cabinets will have final approval by KPU's Electric Metering Department before installation. No open air CT's or PT's will be allowed
- (3) **Indoor Mounted Instrument Transformers:** Instrument transformers installed indoors must have a service size of 1200 amps or greater, be installed inside the customer switchgear in a compartment designated for instrument transformers only, and have prior approval from KPU's Electric Metering Department. KPU reserves the right to refuse indoor installation of instrument transformers.

610.5 New Indoor Primary Metering Equipment Requirements

- (1) When primary metering service is to be installed, the customer shall furnish a compartment or switchgear cubicle to house the primary current and potential instrument transformers. All current and potential instrument transformers shall be rated for metering accuracy as approved by the KPU's Electric Metering Department. The metering point shall be located electrically between the customer's main disconnect and customer's circuits ("cold sequence" metering arrangement)
- (2) When practical, KPU may request that the customer install the primary current and potential transformers per KPU specifications. (Contact a Customer Care Advisor to obtain Engineering assistance.)

610.6 New Outdoor Primary Metering Equipment Requirements – When outdoor primary service is to be installed, KPU may elect to utilize either a pole-mounted or pad-mounted primary metering equipment set. Outdoor primary metering units are furnished and installed by KPU. Sharing of the material and installation costs for primary metering will be determined on a case-by-case basis.

610.7 Existing Service Emergency Repairs – In situations requiring emergency repairs to an existing electrical service where instrument transformers are installed in any location other than an instrument transformer cabinet, the customer/contractor must receive prior approval for the new mounting location of the current transformers from KPU's Electric Metering Department. These types of installations include, but are not limited to:

- (1) Instrument transformers mounted on a pole
- (2) Instrument transformers installed inside a distribution transformer
- (3) Instrument transformers installed inside customer switchgear

611 SELF-CONTAINED METER INSTALLATIONS

611.1 Requirements – In general, KPU will install self-contained meters (meters without instrument transformers) on single or three phase services (240V or less) where the service rating is 400 amps or less (Class 320 meter socket). Where such metering is to be used, the customer shall provide a ringless lever-operated bypassing socket (Refer to Section 613). Such meter sockets permit a continuation of service upon removal of the meter for testing or maintenance. If a lever-operated bypass meter socket is not installed, the service will not be energized.

612 MASTER METERING INSTALLATIONS

612.1 All new residential units will be individually metered.

Exception Provided in Minnesota Rule 326B.106 Subd. 12:

Buildings intended for occupancy primarily by persons who are 62 years of age or older or disabled, supportive housing, or buildings that contain a majority of units not equipped with complete kitchen facilities, shall be exempt from the provisions of this subdivision. For purposes of this section, "supportive housing" means housing made available to individuals and families with multiple barriers to obtaining and maintaining housing, including those who are formerly homeless or at risk of homelessness and those who have a mental illness, substance abuse disorder, debilitating disease, or a combination of these conditions."

- (1) A customer claiming the above exception above takes all legal responsibility for proving the exemption for the life of their building
- (2) Any customer claiming the exception above must provide KPU, in writing, a statement that they are claiming an exception under Minnesota Rule 326B.106 Subd. 12 and why they feel their building meets the requirements for an exception. KPU does not determine the validity of the claimed exception and this required filing is for KPU's documentation only

612.2 All new commercial or industrial units will be individually metered.

Exceptions must be approved by KPU's Electric Metering Department.

612.3 Sub-metering by others for the purpose of charging individual occupants based on measured use must be in accordance with statutory requirements. Sub-metering by others for information purposes or to control the use of electric power for energy is permitted.

613 APPROVED METER SOCKETS

Meter installations made with unapproved meter sockets will not be energized, or subject to disconnection if non-approved equipment is installed. Refer to the table on the following page for a list of meter sockets approved for installation by KPU.

KPU APPROVED METER SOCKETS

SELF CONTAINED	SERVICE VOLTAGES	APPROVED MFG./PART NUMBER
4 Terminal 100A to 320A, Lever Bypass (Residential, 1-Phase)	120V, 2 wire Single Phase OR 120-240V, 3 wire Single Phase OR (240/480V, 200A MAX)	Milbank: U3791, U5844, or U6281 Series GE: TSMB Series Siemens/Talon: UAPB, UAPC, UAP, 4040, 4760, UAB, or LGMN Series Eaton-Cutler Hammer: MBX or CMBX Series
5 Terminal 100A to 320A, Lever Bypass (Residential, 1-Phase)	120V, 2 wire Single Phase OR 120-208V, 3 wire Single Phase OR 120-240V, 3 wire Single Phase Network	Milbank: U3791 or U6281 Series GE: TSMB Series Siemens/Talon: UAPB, UAPC, UAP, 4040, 4760, UAB, or LGMN Series Eaton-Cutler Hammer: MBX or CMBX Series
7 Terminal 400A MAX, Lever Bypass (Commercial, 3-Phase)	120-208V 4-Wire-WYE OR 120-240 4 Wire-DELTA (This service is not allowed for new installations)	Milbank: #U4701-RRL Series Eaton-Cutler Hammer: MBX, CMBX, UTE7213BCH Series Siemens/Talon: UAPB, UAPC, UAP, 4040, 4760, UAB or LGMN Series
INSTRUMENT RATED	SERVICE VOLTAGES	APPROVED MFG./PART NUMBER
6 Terminal Over 400A and larger (Residential or Commercial, 1-Phase)	120-240V, 3 wire Single Phase	Milbank: #UC7478-RL-WC-271 (Pre-wired to KPU spec.)
8 Terminal Over 200A and larger (Commercial 3-Phase)	120-240 3 Wire-DELTA	Contact KPU for approval
13 Terminal 100A and larger (Commercial, 3-Phase)	120-208V, 277-480V 4-Wire-WYE OR 120-240 4 Wire-DELTA (This service is not allowed for new installations)	Milbank: #UC7445-RL-WC-951 (Pre-wired to KPU spec.)

614 SERVICE AT 480 VOLTS

All 277/480V metering services will require the installation of CT's and VT's. KPU will supply and install all metering CT's and VT's at no cost to the customer/contractor.

Exception:

Self-contained services (200A or smaller) supplying roadway lighting operating at 240/480V and fed from a single phase transformer only supplying the lighting service shall be exempt from the above requirement

615 LOCATION OF HIGH-LEG IN METER SOCKET ON 240/120 VOLT, 3-PHASE SERVICES

The conductor with the higher voltage to ground must be connected to the terminal on the right side. The high-leg conductor must be identified as required by the National Electric Code®. Meter sockets with the high-leg in the wrong position will not be energized. Incorrectly wired sockets will be subject to disconnection until wiring is corrected.

616 REMOVING KPU SEALS AND METERS

Disconnection of KPU metering equipment and cutting of seals is not allowed.

617 CUSTOMER GENERATION

Refer to Section 500 – Distributed Energy Resources for metering requirements pertaining to DER facilities interconnected to KPU's distribution system.

618 PROPER GROUNDING/BONDING OF METER SOCKETS & SERVICES

618.1 Proper Grounding/Bonding – Service equipment and enclosures may need to carry heavy fault currents in the event of a ground-fault. For this reason, it is imperative that meter sockets and conduits be adequately bonded to the neutral and to the ground. Bonding is to be done by threaded couplings and threaded bosses in a rigid metal conduit system where the joints will be made up wrench tight. Locknuts and bushings do not fulfill the requirement of bonding at service equipment. Grounding bushing (with bonding jumpers), bonding locknuts, threaded conduit hubs, or other means are approved (Refer to National Electric Code® Article 250). All metering conduits and sockets must be properly grounded. If PVC conduits are used, grounding conductors must be provided and installed by the customer or electrical contractor in accordance with the National Electric Code®. Electric services will not be connected if improperly grounded/bonded upon inspection. Refer to the Typical Grounding/Bonding for CT Cabinet and Gutter drawing below for additional details:

TYPICAL GROUNDING/BONDING FOR CT CABINET AND GUTTER

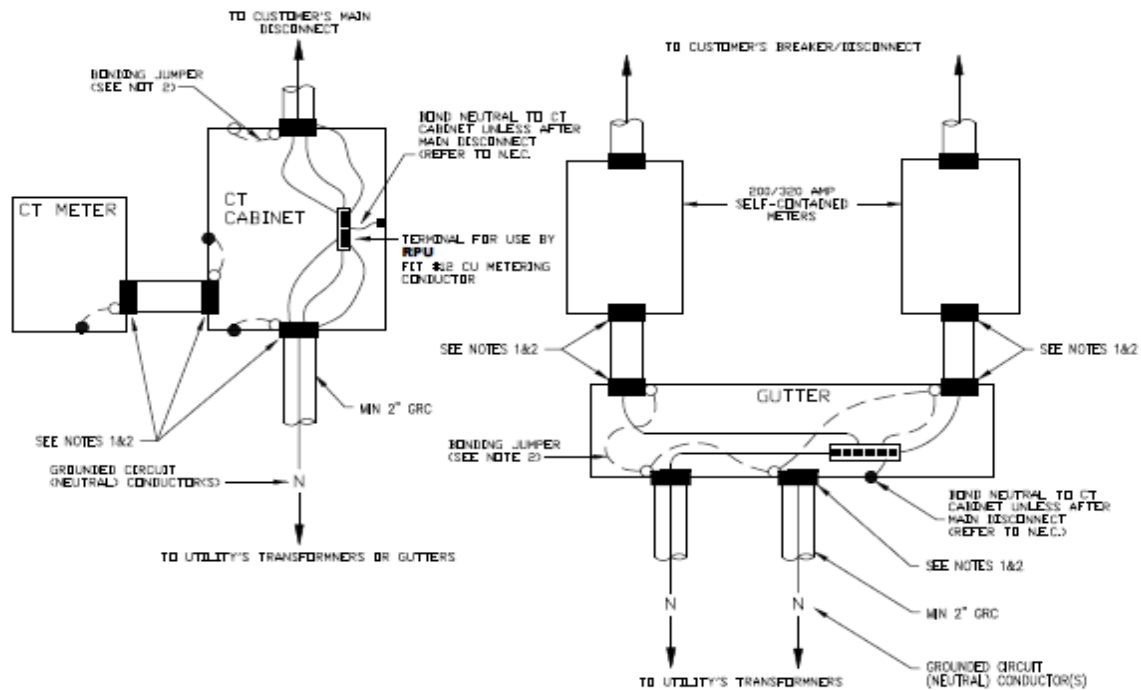

NOTES:

1. The metal conduit raceway (PVC is allowed on the load side of the meter socket or CT cabinet) shall be bonded to the neutral conductor by the use of a grounding bushing (with bonding jumper), bonding locknuts, threaded conduit hub.
2. When a grounding bushing is used, a bonding jumper shall be installed to connect with the bonded enclosure. The bonding jumpers shall be sized to meet NEC Table 250.102(c)(1). Bonding to be completed by contractor.

SIZE OF LARGES SERVICE ENTRANCE CONDUCTOR OR EQUIVALENT AREA FOR PARALLEL CONDUCTORS		SIZE OF BONDING JUMPER CONDUCTOR
COPPER	ALUMINUM OR COPPER-CLAD ALUMINUM	COPPER
#1/0 or smaller	#3/0 or smaller	6
#2/0 or #3/0	#4/0 or 250 kcmil	4
Over #3/0 thru 350 kcmil	Over 250 kcmil thru 500 kcmil	2
Over 350 kcmil thru 600 kcmil	Over 500 kcmil thru 900 kcmil	#1/0
Over 600 kcmil thru 1100 kcmil	Over 900 kcmil thru 1750 kcmil	#2/0
Over 1100 kcmil	Over 1750 kcmil	#3/0 or 12 5/8% of conductor kcmil, whichever is larger

3. All neutral conductors shall be terminated in CT cabinets and gutters to a common connection.

618.2 Neutral for 5 and 7 Terminal Sockets - A system neutral is required to each 5 and 7 terminal socket. Conductor should be sized in accordance with the National Electric Code®.

619 CUSTOMER DISCONNECT SWITCH

619.1 Location – Disconnect switches shall be installed in a location that meets the same requirements for location as those for electric meters (Refer to Section 602)

619.2 Residential Customers – Individual Customer disconnect switches shall be connected on the load side of the meter. No customer devices, e.g. surge suppressors, load management equipment, etc., may be installed on the line side of the meter.

619.3 Non-residential Customers – Each installation must have a separate securable disconnect, installed on the load side of the meter, and accessible to KPU at all times. If the building is a multi-tenant building, each non-residential customer must have a separate securable disconnect installed on the load side of the meter. The securable disconnect shall be labeled and mounted adjacent to the meter location.

620 SPECIAL SOCKETS

All special sockets, such as ganged meter sockets and free-standing metering pedestals, must have KPU Engineering approval prior to installation.

621 KPU OWNED EQUIPMENT

Any metering equipment furnished by KPU, such as meters, instrument transformers, relays, totalizers, test switches, etc., remain the property of KPU. If the equipment has to be removed or disconnected for any reasons, please call KPU so that the equipment can be picked up.

622 TEMPORARY REMOVAL OF CUSTOMER OWNED METER SOCKETS

Any meter socket removal request will be at the discretion of KPU's personnel. Should KPU's personnel not be able to perform the work, it will be up to the customer to hire an electrician/contractor to perform the task. If at any time safety is a concern, KPU will have the service de-energized to perform the work. The customer/contractor shall contact KPU two (2) business days in advance to schedule the temporary removal of the meter socket for siding purposes.

623 PULSE INITIATING DEVICE

Upon the customer's request, the customer/contractor will install a pulse-initiating device on a customer's existing meter socket. To initiate a request for a pulse-initiating device, the customer shall contact KPU. The customer should submit, in writing, all technical information concerning the customer's load-monitoring equipment to KPU. KPU will determine what type of pulse and the amount of pulses available in a given time interval. The customer/contractor will install a weatherproof junction box, a 3 to 5 position fused terminal block, a 3/4-inch galvanized rigid conduit with ground wire from the meter socket to the weatherproof junction box. The customer will furnish, install and maintain all necessary equipment. This wiring will be in accordance with the requirements of the electrical code governing such installation with KPU stipulation that one-amp current limiting fuses be installed on the load side of the terminal block. KPU will then install pulse-initiating device and wiring from the meter socket to the

terminal block. Note: KPU's responsibility and liability ends at the line side of the terminal block. **KPU reserves the right to interrupt pulses at any time in order to test or change the meter and to change the pulse value whenever it becomes necessary to upgrade the metering equipment. Every effort will be made to notify the customer when it becomes necessary to interrupt pulses for equipment maintenance. The customer will be notified of any change to the pulse values.**

CUSTOMER CONNECTIONS FOR PULSE-INITIATING DEVICE INSTALLATION

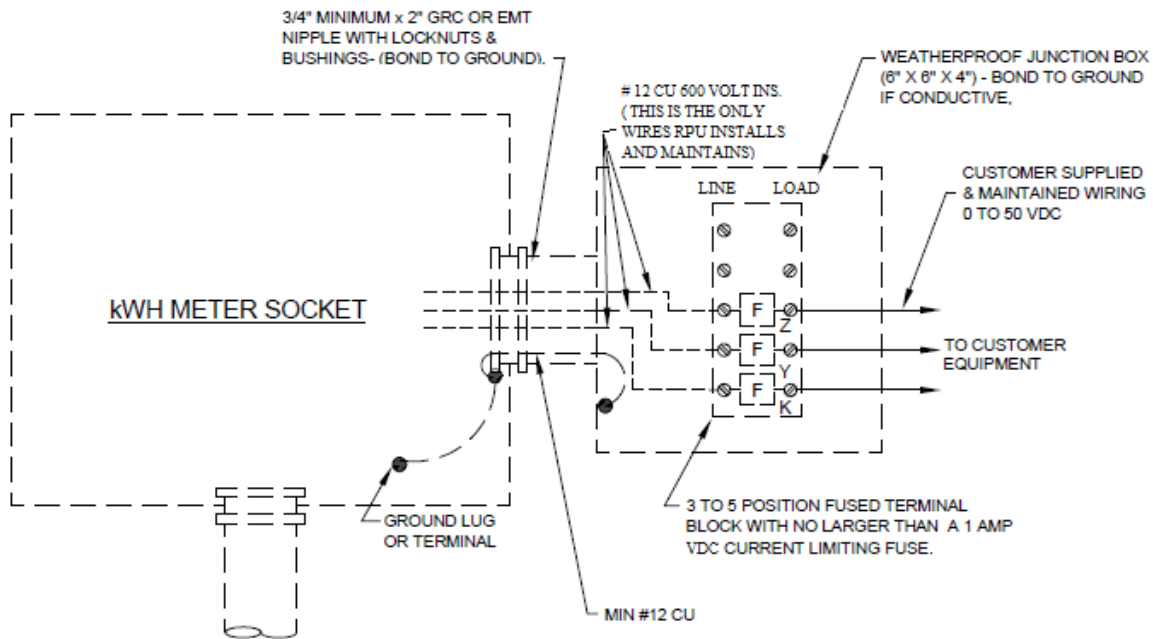

PULSE INITIATING DEVICE INSTALLATION

SECTION 700 – CUSTOMER UTILIZATION EQUIPMENT

The customer's service entrance and utilization equipment shall be installed in accordance with all local, state, and National Electrical Code® requirements. It is the intent of this section to provide the customer with recommendations concerning factors that can affect both KPU and the customer in the selection, installation, maintenance, and operation of the customer's utilization equipment. If concerns arise that are not covered in this section, please contact a KPU Electric Dept. Representative for assistance.

701 PROTECTION OF CUSTOMER EQUIPMENT

701.1 General – The customer is advised to provide adequate protection against the effects of outages or voltage spikes in accordance with the National Electric Code® or other pertinent sources of information for all types of motors and other equipment. Equipment that should be protected includes, but is not limited to:

- (1) Motors
- (2) Computers
- (3) Electronic Equipment
- (4) Equipment in which computers or electronics form an integral operating part

701.2 Protection Conditions – Equipment should be protected under all conditions, including:

- (1) Overload
- (2) Voltage Loss
- (3) High or low voltage
- (4) Phase loss (e.g. single phasing on polyphase motors)
- (5) Re-establishment of service after any of the foregoing
- (6) Phase reversal
- (7) Motors that cannot be subjected to full voltage on starting
- (8) Harmonics or wave form irregularities

701.3 Failure to Protect – Failure to provide such protection may result in needless damage to equipment and the expense of delay and repair.

701.4 Sensitive Electronics – Sensitive electronics, such as microprocessor-based home electronics and business computers, are susceptible to damage due

to voltage spikes or surges. Before any microprocessor-based electronics are installed:

- (1) Wiring practices that meet manufacturer specifications need to be assured (e.g. proper grounding and dedicated circuits are important)
- (2) Consideration should be given to installation of transient voltage surge suppression
 - a) At the main service entrance
 - b) At the point of use
- (3) An uninterrupted power supply (battery backup) should be considered if a momentary voltage dip or outage would cause loss of data

702 MOTOR STARTING CURRENTS

702.1 General – Typically, all motors require a starting current substantially greater than their normal running current. Where starting currents are excessive, an abnormal drop in supply voltage will result. In order to minimize the unfavorable effects of such voltage drops, it is essential that the customer's motors do not exceed the allowable starting characteristics as shown in Table 430-251(A and B) of the National Electric Code®.

NOTE: Customers planning to install any motor larger than 5 HP single phase or 25 HP three phase, must contact KPU Engineering. Motor installations that cause power quality problems for other customers shall be corrected at the owner's expense.

702.2 Voltage Flicker – KPU uses IEEE Standard 141 (IEEE Red Book) as a guideline for the level of allowable flicker. Customers are not allowed to start any load on KPU's system that produces unacceptable levels of flicker which affect other customers. Customers are responsible for correcting unacceptable flicker problems in a timely manner when notified by KPU.

703 POWER FACTOR

703.1 Requirements – In order to improve the efficiency of KPU's distribution system, the customer's utilization equipment shall maintain an average power factor as close to unity as possible.

703.2 Penalties – Some of KPU's rate schedules include a demand charge and a penalty for an average power factor that is less than 95%. Details of the method of billing for such customers can be obtained from an KPU Utility Billing Specialist. For new services, it is suggested that the customer's utilization equipment be designed for operation at high power factor or with capacitors that are switched on and off with the equipment. Refer to Section 1109, Table 11.1 for correcting customer's power factor.

703.3 Calculation – KPU will calculate the power factor of customers in designed rate classes by the power factor calculated and displayed by the utility’s revenue grade meter.

704 FAULT CURRENTS

The customer’s service equipment and other devices shall be adequate to withstand and interrupt the maximum available fault current. For single-family residences with service equipment rated 200 amperes maximum and 120/240 volts, single phase, equipment shall have a minimum interrupting rate of 10,000 amperes symmetrical and other equipment shall be braced to withstand that minimum value. Refer to Section 1003 for more information.

705 WIRING ADEQUACY

The National Electrical Code® (NFPA No. 70) specifies the adequacy of wiring with respect to safety; however, such installations may not be efficient or adequate for future expansion of electrical use.

706 CUSTOMER-OWNED GENERATING EQUIPMENT

Unless authorized by written agreement, electric generating equipment installed by the Customer shall not be interconnected or operated in parallel with KPU’s distribution system. The customer shall own, install, operate, and maintain electrical interlocking equipment which will prevent parallel operation and such equipment shall be approved by KPU prior to installation.

706.1 Distributed Energy Resources (DER) – For generation and storage systems designed to operate in parallel with KPU’s distribution system, refer to Section 500 for requirements governing this type of installation.

707 CUSTOMER’S OBLIGATIONS

707.1 Increased Load – In the event the customer desires to increase load materially, such as adding electric heat, increased motor loads, EV chargers, etc., they shall give KPU sufficient advance notice, so that KPU may provide added facilities if necessary. If the customer fails to notify KPU and KPU’s equipment is damaged as a result of such increased load, the customer shall reimburse and make payment to KPU for all such damages.

707.2 Balancing of Load – Except in the case of three-phase, four-wire delta services, the current unbalance in three-phase services shall not exceed 10 percent of the current that would be required at maximum load under balanced conditions.

707.3 Total Harmonic Distortion (THD) Requirements

- (1) Nonlinear Load – The application of any nonlinear load by the customer (e.g. static power converters, arc furnaces, adjustable speed drive systems, etc.) shall not cause voltage and/or current Total Harmonic Distortion (THD) levels greater than industry accepted levels on KPU's electric system at the point of power delivery to the customer's facility (Refer to IEEE Standard 519)
- (2) Nonlinear Load Disclosure – the customer shall disclose to KPU all nonlinear loads prior to connection. KPU may test the customer's load to determine the THD levels
- (3) Nonlinear Load Responsibilities – It shall be the responsibility of the customer to assure that the THD requirements are met, including the purchase of necessary filtering equipment. Any load found not in compliance with this policy shall be corrected immediately by the customer at the customer's expense. If not corrected, KPU may disconnect service to the customer's facility
- (4) Nonlinear Load Damages – The customer shall be liable for all damages, losses, claims, costs, expenses and liabilities of any kind or nature arising out of, caused by, or in any way connected with the application by the customer of any nonlinear load operating with maximum THD levels in excess of the values stated in Section 707.3(1) above. The customer shall hold harmless and indemnify KPU from and against any claims, losses, costs of investigation, expenses, reasonable attorney's fees, damages and liabilities of any kind or nature arising out of, caused by, or in any way connected with the application by the customer of any nonlinear load operating with maximum THD levels in excess of the values stated in Section 707.3(1) above

SECTION 800 – OVERHEAD SECONDARY SERVICES

KPU will supply overhead secondary service (600 volts or less) only if any and all reasonable underground options are unavailable as determined by KPU, in areas where overhead facilities are available, at the voltages and under the conditions specified in other sections of this publication. The service entrance location will be specified by KPU. This section includes information on distribution transformer size, overhead service drop, and connections to the customer's premises or equipment. Metering and customer equipment requirements are covered in other sections of this publication. The requirements of this section apply to all residential, commercial, and industrial customers.

801 MAXIMUM TRANSFORMER SIZE

801.1 Maximum Size – The maximum standard overhead transformer size installed by KPU will be either one 50 kVA transformer for a single-phase application or three 15 kVA transformers for multiphase applications. If a larger transformer size is required for a particular application, it shall be a pad-mounted type.

801.2 Number of Secondary Services – One (1) or more secondary services may be supplied from a transformer; the number of services from a transformer shall be determined by KPU depending upon the application.

802 SERVICE DROP CONDUCTORS

802.1 New Services – The service drop for new services will be a twisted wire triplex (3 wires) or quadruplex (4 wires) configuration from the distribution system to the point of attachment on the customer's premises.

802.2 Existing Services – The service drop may either be a twisted wire or open wire configuration. If necessary for various reasons, KPU may change a service from an open wire to a twisted wire configuration.

803 CLEARANCES

803.1 Required Clearances (Roofs, Balconies & Windows/Doors) – The service drop must be so located that the minimum clearance as specified in the latest editions of the National Electrical Code® and the National Electric Safety Code® are maintained. Illustration drawings of the clearances required are shown in Section 1200, Exhibits 4, 4.1, and 4.2. Please contact KPU's Engineering Department if there are any questions about the clearances depicted. KPU will not energize an electric service with an observed clearance violation.

803.2 Required Clearances (Patios, Pools & Hot Tubs) – Service drop conductors must be located so that the minimum clearance as specified in the latest editions of the National Electrical Code® and the National Electric Safety

Code® are maintained. Illustration drawings of the clearances required are shown in Section 1200, Exhibits 4.3, 4.4 and 4.5. Please contact KPU's Engineering Department if there are any questions about the clearances depicted. KPU will not energize an electric service with an observed clearance violation.

804 POINT OF ATTACHMENT

804.1 Buildings – A solid point of attachment for supporting the service drop on the building shall be provided by the customer at a point which will comply with previously stated clearances in Section 803. Where the required heights and clearances cannot be maintained by a point of attachment on the building, the customer shall provide a service mast which is of a permanent nature and of sufficient strength to support the service drop at the required minimum clearance. Illustration drawings of the attachment clearances and service mast installations are shown in Section 1200, Exhibits 6 and 6.1. In such an installation, 2-inch or larger galvanized iron conduit or 3-inch or larger rigid aluminum conduit shall be used. KPU reserves the right to decline to connect its service drop to an extension support, which, in its judgment, constitutes a hazard to life or property.

805 SERVICE ENTRANCE

805.1 Location – The customer's service entrance wiring shall terminate at a point so located that the service drop from the supply lines will not interfere with windows, doors, awnings, drainpipes, or other parts of the building or other obstructions so that only one bracket is required.

805.2 Customer's Responsibility – Customer's portion of the service entrance shall consist of the point of attachment (house knob, service mast and guy wires), conduit from the meter socket, a weather head, and wire. Tails shall be left on the customer's service wires extending a minimum of three (3) feet beyond the weather head. The neutral wire shall be identified and shall be continuous (no cut) from the weather head to the entrance switch (unless otherwise approved by KPU).

SECTION 900 – UNDERGROUND SERVICES

901 NEW RESIDENTIAL DEVELOPMENTS

901.1 Point of Delivery – KPU will designate a point of delivery for the connection of the customer's secondary underground service. The point of delivery may be the secondary terminals of a pad-mounted transformer, service pedestal, or secondary vault. In general, KPU will install, own, operate, and maintain all facilities on the source side of the point of delivery, including the junction cabinet and connections; the customer will install, own, operate, and maintain all secondary cables, conduit, and related service equipment specified in other sections of this publication on the load side of the point of delivery.

901.2 Point of Delivery Location – Points of delivery will be located within KPU's easement area along or near a front or rear property line unless it is necessary or desirable to designate locations which are closer to the metering point(s). In such cases, the customer will be charged for the installed cost of any additional lengths of underground distribution cable and conduit from the property line to the point of delivery. Such charges shall be in addition to any other charges specified herein.

901.3 Responsibilities – Additional information regarding KPU and customer responsibilities for URD installations is provided in Section 1200, Exhibit 9.

902 RESIDENTIAL UNDERGROUNDING IN OVERHEAD AREAS

902.1 Customer Initiated – Customers residing in residential zones presently served by overhead lines may request underground electric service. Customers intending to relocate, upgrade, or replace an existing overhead service are required to convert to underground service. In either situation, the customer shall own, operate, and maintain the facilities specified in Section 901 above. KPU will provide 1/0 or 4/0 URD triplex at the electrician's request.

902.2 Additional Customer Responsibilities – Customers replacing an existing overhead service with an underground service will install the service conductors to an KPU installed secondary pedestal. The location of the pedestal will be determined by KPU. The customer should contact KPU's Engineering Department for more details prior to proceeding.

903 UNDERGROUND SERVICE TO COMMERCIAL & INDUSTRIAL CUSTOMERS

903.1 Where Required – KPU requires the underground installation of primary and secondary distribution service to new commercial and industrial structures.

903.2 Point of Delivery – KPU will designate a point of delivery for the connection of the customer's secondary underground service lateral. The point of delivery will normally be the secondary terminals of a pad-mounted transformer placed at a mutually agreeable location on the customer's property, as close as practicable to the metering point.

903.3 KPU Owned Material – KPU will install, own, operate, and maintain the primary underground cable, the distribution transformer, and the secondary connections at the distribution transformer.

903.4 Conduit Required (KPU Underground Facilities) – If underground primary distribution facilities are located on the customer's property, the customer or their electrical contractor shall provide the conduit from a designated point of interconnection to the distribution transformer.

903.5 Conduit Required (KPU Overhead Facilities) – If overhead main distribution facilities are located on or adjacent to the customer's property, the customer shall provide conduit from the riser pole, including the long sweep elbows, to the pad-mounted distribution transformer. Refer to Section 1200, Exhibit 8 for details.

903.6 Concrete Transformer Pad – The customer shall install, own and maintain a concrete transformer pad constructed to KPU specifications.

- (1) If the transformer is located in an area subject to physical damage (e.g. from vehicular traffic), KPU will require the customer to furnish and install an approved means of protection (such as bollards)
- (2) The customer will be required to construct or position the concrete transformer pad in such a way to avoid other types of transformer damage, such as corrosion resulting from snow-melt chemicals

903.7 Customer Owned Material – The customer shall install, own, and maintain all secondary cables, conduits, and cabinets from the transformer or secondary pedestal to the building service entrance.

- (1) **Secondary Bus Duct** – KPU must approve the design of all secondary bus duct and cable bus designs. The installation may be inspected by KPU and the secondary connections to the transformer and the transformer side of the connection cabinet will be made by KPU

- (2) Customer Coordination – It is the customer’s responsibility to coordinate with and provide the necessary information to KPU to assure that adequate connections are made at the secondary terminals of the transformer

903.8 Metering – KPU will furnish and install the meter set in accordance with the requirements of Section 600.

903.9 Maximum Secondary Connections – The maximum number of secondary connections available shall be:

- (1) Single Phase: Six (6) 350 MCM conductors per phase
- (2) Three Phase:

TRANSFORMER SIZE	# OF CONDUCTORS PER PHASE
45 KVA	3
75 KVA to 500kVA	6
750kVA to 2500kVA	10

- (3) The maximum size secondary conductor to be installed in a 3-phase transformer is 500 MCM. Conductors may be aluminum or copper and parallel conductors shall be of identical wire size

Exception: Where the customer’s NEC ® service ampacity requirement (as determined by others) exceeds the maximum allowable cable quantity shown above for 500 MCM copper conductors at 90°C temperature rating, contact KPU’s Engineering Department for assistance.

- (4) Any service requiring more conductors per phase than listed above must utilize a customer provided secondary connection cabinet complying with the requirements of Section 904

903.10 Manhole Secondary Connections – Secondary cables installed in an KPU manhole must be copper conductor.

904 SECONDARY CONNECTION CABINETS

904.1 General – Where secondary connection cabinets are necessary, the following requirements apply:

- (1) Cabinet assemblies will be suitable for the installation and comply with all KPU and National Electric Code® requirements
- (2) Cabinets shall be constructed with provisions for bar-type or donut-type current transformers

- (3) Conduits from service equipment to the connection cabinet and from the transformer to connection cabinet will be furnished and installed by electrical contractor as concrete pads are being formed and poured. Conduit systems shall meet KPU requirements. Above-grade raceway from the transformer to the connection cabinet is not allowed.

904.2 Clearance Requirements – Secondary connection cabinets must be installed such that the minimum clearance requirements for pad-mounted transformers specified in Section 1200, Exhibit 7 are maintained.

904.3 Inspections – During the required transformer pad inspection, if the secondary connection cabinet is found to be in violation of the minimum required pad-mount transformer clearances, the inspection will be marked as 'FAILED'. The contractor will need to correct the observed deficiencies and submit a new form for inspection.

905 TRANSFORMER CLEARANCES

Where pad-mounted transformers are installed, the minimum clearances specified and shown in Section 1200, Exhibit 7 must be maintained. Fences, shrubbery, manholes, junction boxes, and trees may be installed by the customer if the specified clearances are maintained, grade is not altered, and the underground cable is not endangered.

906 OTHER PAD-MOUNTED EQUIPMENT CLEARANCES

Where pad-mounted equipment such as capacitor banks, switchgear, or primary metering cabinets are installed, the following minimum clearances shall be provided:

- (1) Ten (10) feet in front of the access doors
- (2) Three (3) feet from the sides and/or back of the equipment

The above minimum clearances must be at the same grade as the equipment.

907 WINTER INSTALLATION

The customer shall be required to pay a per foot additional fee for underground cable installation, at the customer's request, after frost has been established in the ground to an average depth of 6 inches or more. The amount of the frost fee depends on the depth of the frost. KPU may require that the estimated frost charges be paid in advance of performing work.

908 INSTALLATIONS IN UNSUITABLE SOILS

The customer shall be required to pay an additional fee if unsuitable backfill material is encountered during the installation of KPU's facilities. The fee will be

based on the cubic feet of unsuitable backfill material encountered by KPU or our contractor during installation. KPU may require that the customer pay an estimated fee prior to performing the work.

909 TOTAL UNDERGROUNDING

KPU does not install underground vaults, manholes, or submersible transformers on customer property. If the presence of permanent structures up to the property lines, or other conditions, precludes the installation of pad-mounted equipment on the customer's property, primary service will normally be provided.

SECTION 1000 – TRANSFORMERS AND TRANSFORMER DATA

1001 TRANSFORMERS

1001.1 Ownership – Necessary transformers will be installed and maintained by KPU in accordance with its established Rate Schedules and Electric Service Rules and Regulations.

1001.2 Requirements – KPU will not furnish transformers unless they are of standard size and voltage as established by KPU. The customer shall notify KPU in advance of any change in the customer's load requirements that may affect the installed transformer capacity.

1002 GROUNDING

1002.1 Grounded System – All service systems that operate below 600 volts contain a grounded neutral or a grounded phase conductor used as a circuit conductor in the system. The grounded neutral or grounded phase conductor is grounded at the supply transformer and will be run from the transformer bank to the meter socket and to each service disconnection means in accordance with National Electric Code® Article 250.24(B), or as may be amended.

1002.2 Ungrounded System – Customers requiring an ungrounded service for operation of a ground detection system, or for other operations permitted by the National Electric Safety Code®, shall submit an exception request detailing the special circumstances necessitating the request. In addition, the customer shall state in the exception request that he is aware of and accepts the increased risk to personal safety associated with an ungrounded service. When supplying an ungrounded service results in an additional cost to KPU, the additional cost may be passed on to the customer.

1003 SPECIAL RULES

1003.1 Customer Furnished Equipment – When a customer is furnished primary service by KPU and installs transformers or other equipment, in accordance with the applicable KPU rate schedule and Electric Service Rules & Regulations, KPU accepts no responsibility for maintaining or replacing the customer's transformers or other equipment if damaged or destroyed.

1003.2 Required Clearances – The customer shall provide a minimum of ten (10) feet of level clearance on the door side(s) of pad-mounted transformers for hot-stick operation and ten (10) feet level clearance on the door side(s) of pad-mounted primary metering cabinets for instrument transformer maintenance. KPU reserves the right to remove obstructions such as fences, landscaping, decorative bushes, etc. at any time and shall not be held liable for restoration of, or any costs associated with removal of said obstructions. Additional clearance requirements are located in Section 1200, Exhibit 7.

1003.3 Easements and Right of Way Obstructions – Fences, trees, landscaping, gardens, etc. located in an easement or right of way will be removed at any time deemed necessary by KPU to maintain electrical equipment, lines, etc. City Ordinance prohibits the installation of fences or any customer owned property located on or in a right of way or utility easement. The City of Kasson or its employees, contractors, etc. will not be held physically or financially liable for removal of obstructions. All efforts to provide notice of removal will be made in a reasonable timeframe to allow removal by the customer. Emergency situations will necessitate little to no notice to customers.

1004 FAULT CURRENT

1004.1 Intention – It is KPU’s intent to address the customer’s need for information concerning fault current and transformer protective device requirements pertaining to new construction, rewiring, or additional load. Refer to the current edition of the National Electric Code®, Article 110.9 Interrupting Rating and Article 110.16 Arc Flash Hazard Warning, or as may be amended.

1004.2 Tables – Tables 10.1 through 10.3 in this Section show the maximum available RMS symmetrical fault current that may be expected at the secondary terminals of distribution transformers. Each fault current value listed in the tables is based on the percent impedance value of the transformer that might be set initially or as a replacement. No primary source or secondary line impedance has been included since it is generally relatively small, may change, and cannot be accurately forecasted.

Note: Because an overloaded transformer is typically replaced with the next larger standard size transformer, and an under-loaded transformer may be replaced with the next smaller standard size transformer, the customer shall use this range of transformers to perform their analysis and select equipment such as fuse or circuit breakers and service entrance bus bar bracing. When selecting the fault current interrupting rating of the customer protection devices, the customer should also take into account the minimum size transformer that would be required to serve the load rating of the customer main protection device.

1004.3 Variability – Due to the variability of the transformer and electric distribution system characteristics, these tables should be used as a general guideline and shall not be used as a design tool to replace engineering that may be required by the Code Authorities having jurisdiction. Customers or contractors requiring specific fault current calculations should consult a registered professional engineer of their choice.

Note 1: All installations served from a single-phase pad-mount transformer should as a minimum use the calculations based on the installation of a 37.5 kVA transformer.

Note 2: All temporary construction meter installations may use the actual transformer size.

1005 ARC FLASH

1005.1 Intention – It is KPU’s intent to address the customer’s need for information concerning arc flash data requests as follows:

- (1) For secondary voltage services, KPU will provide upon request from the customer:
 - a) Transformer size, primary voltage, secondary voltage and typical transformer percent impedance
 - b) Transformer primary fuse information and size type
 - c) Calculated symmetrical bolted three-phase fault current, bolted single-line ground fault current, and calculated system impedance (R and X) at the high side of the transformer
 - d) The upstream protective device information nearest the service point. This information will include the device model, rating and applicable settings
- (2) For primary voltage services, KPU will provide upon request from the customer:
- (3) Calculated symmetrical bolted three-phase fault current, bolted single-line ground fault current and calculated system impedance (R and X) at the service point
- (4) The upstream protective device information nearest the service point. This information will include the device model, rating and applicable settings

1005.2 Calculations – Fault current calculations are based upon the distribution system configuration at the time of the calculations. KPU does not provide minimum fault current information or associated protective device clearing times.

1005.3 Use of Data – It is understood that this data is to be used for arc flash calculations. Parties using this data must understand that it may change due to various reasons. KPU will not notify the customer when such changes occur.

1005.4 Table Data – Tables 10.1 through 10.3 in this Section are only intended to provide the basic information necessary for secondary service customers to make their own internal system fault current and basic arc flash calculations. Primary service customers will still need to consult with KPU’s Engineering Department to obtain fault current and protective device information for their service locations.

Note: As a safety measure, KPU recommends that when customers are performing maintenance work on or near exposed electrical equipment that their electrical system be de-energized whenever possible.

Table 10.1 Single Phase Underground

SINGLE-PHASE PADMOUNT TRANSFORMERS						
EXPECTED SINGLE-PHASE FAULT CURRENTS (IN RMS AMPS) AT THE SECONDARY TERMINALS						
					PROTECTIVE DEVICE, OVERHEAD FUSE	
TRAN	TRAN	TRAN	TRAN	Fault Current	7960V PRIMARY	
KVA	%Z	%R	%X	240V Secondary	BAY-O-NET	Amps
5	1.00	0.39	0.92	2,085	4000358C05	8
15	1.00	0.39	0.92	6,250	4000358C05	8
25	1.00	0.32	0.95	10,420	4000358C08	15
37.5	1.00	0.25	0.97	15,630	4000358C08	15
50	1.10	0.57	0.94	18,940	4000358C08	15
75	1.10	0.38	1.03	28,410	4000358C10	25
100	1.10	0.34	1.05	37,880	4000358C10	25
167	1.20	0.34	1.05	57,990	4000358C12	50
					PROTECTIVE DEVICE, OVERHEAD FUSE	
TRAN	TRAN	TRAN	TRAN	Fault Current	7960V PRIMARY	
KVA	%Z	%R	%X	480V Secondary	BAY-O-NET	Amps
15	1.1	0.39	1.03	2,840	4000358C05	8
Note: BAY-O-NET fuse is a COOPER/EATON or equivalent						

Table 10.2 Single Phase Overhead

SINGLE-PHASE OVERHEAD TRANSFORMERS										
EXPECTED SINGLE-PHASE FAULT CURRENTS (IN RMS AMPS) AT THE SECONDARY TERMINALS										
									PROTECTIVE DEVICE, OVERHEAD FUSE	
TRAN	TRAN	TRAN	TRAN	Fault Current	TRAN	TRAN	TRAN	Fault Current	7960V PRIMARY	
KVA	%Z	%R	%X	240V Secondary	%Z	%R	%X	120V Secondary	Typical	Limited Use
10	1.20	0.35	1.15	3,470	1.48	0.53	1.38	5,630	1.5X	6 ELF
15	1.20	0.66	1.00	5,210	1.56	0.99	1.20	8,010	2X	6 ELF
25	1.20	0.50	1.09	8,680	1.51	0.75	1.31	13,800	3.5X	6 ELF
37.5	1.20	0.39	1.13	13,020	1.48	0.59	1.36	21,110	5.5X	8 ELF
50	1.20	0.43	1.12	17,360	1.49	0.65	1.34	27,960	7X	12 ELF
75	1.20	0.17	1.19	26,040	1.45	0.26	1.43	43,100	10X	18 ELF
167	1.20	0.17	1.19	57,990	1.45	0.26	1.43	95,980	25KS	18 ELF

Table 10.3: Three Phase Pad-mount Transformers

THREE-PHASE PADMOUNT TRANSFORMERS									
EXPECTED THREE-PHASE FAULT CURRENTS (IN RMS AMPS) AT THE SECONDARY TERMINALS									
						TRANSFORMER PROTECTIVE DATA			
TRAN	TRAN	TRAN	TRAN	Fault Current	Fault Current	Current Limiting	Size	BAY-O-NET	Size
KVA	%Z	%R	%X	120/208V Secondary	277/480V Secondary	Cooper/Eaton or Equivalent	Amps	Cooper/Eaton or Equivalent	Amps
45	1.3	1.04	0.78	9,600	N/A	CBUC08030C100	30	4000358C05	8
75	1.3	0.7	1.10	16,000	6,900	CBUC08080C100	80	4000358C08	15
112.5	1.4	0.49	1.31	22,300	9,700	CBUC08080C100	80	4000358C08	15
150	1.4	0.35	1.36	29,700	12,900	CBUC08080C100	80	4000358C08	15
225	1.4	0.43	1.33	44,600	19,300	CBUC08100C100	100	4000358C10	25
300	1.4	0.48	1.32	59,500	25,800	CBUC08125C100	125	4000358C10	25
500	1.6	0.40	1.55	86,700	37,600	CBUC08150D100	150	4000358C12	50
750	4.5	0.39	4.48	46,300	20,000	CBUC08250D100	250	4000358C14	65
1,000	5.1	0.32	5.09	54,400	23,600	CBUC08150D100	150	4038361C03CB	135
1,500	5.1	0.36	5.09	N/A	35,400	CBUC08150D100	150	4038361C03CB	135
2,000	5.1	0.43	5.08	N/A	47,200	CBUC08165D100	165	4038361C04CB	165
2,500	5.1	0.33	5.09	N/A	59,000	CBUC08250D100	250	4038361C05CB	185

SECTION 1100 – SUPPLEMENTAL INFORMATION

1101 USE OF SERVICE

1101.1 Purpose – Electric service may be used only for the purposes set forth in the respective rate schedules. KPU is in the business of providing retail electricity to the ultimate consumer. Electricity is supplied for use by customer’s household or business, and outside sale of such service is not permitted. KPU permits redistribution and sub-metering where allowed by law, but a landlord may not charge the tenants more than the landlord is charged by KPU.

1101.2 Arrangement – The electric service equipment and associated building wiring of buildings must be arranged by the owner to facilitate individual metering of the electrical consumption of each building and occupancy unit. (Minnesota Statute Section 326B.106 Subd.12 requires separate metering on most residential units). If desired by the owner, KPU will install and maintain necessary individual KPU meters to measure consumption and tender bills on the applicable rate schedules to each customer and separately occupied buildings and occupancy units. Installation and maintenance of individual KPU meters by KPU shall not relieve the owner or landlord of responsibility for electrical service equipment and associated building wiring, nor shall it relieve the owner or landlord of responsibility to notify KPU of a single-metered residential building.

1101.3 Metering – Electric service in a single-metered residential building, as defined pursuant to Minn. Stat. 504B.215, shall be billed to the landlord/building owner except when a de minimis exception exists. A de minimis exception to the determination that a building is a single-metered residential building exists if electrical service used in a common area but measured by an individual tenant’s meter does not exceed an aggregate 1,752 kilowatt hours per year. The landlord shall bear the burden and cost associated with proving an exception. (Minnesota Statute 504B.215 Subd. 2 requires the landlord of a single-metered residential building shall be the bill payer responsible, and shall be the customer of record contracting with the utility, and requires the landlord to advise the utility of the existence of a single-metered residential building). Except where a de minimis exception applies, a single metered residential building includes the following situations: “shared meter” in which a utility meter measures service provided to a tenant’s dwelling and also measures such service to areas outside that dwelling; or “mixed wiring” in which electric outlets, fixtures or devices outside the individual unit are included on an individual meter; or “mixed plumbing” when related to electric utility service such as when an electric water heater serves more than one individual unit. KPU shall respond to a tenant customer’s request for a shared meter investigation within ten (10) business

days. KPU's investigation shall consider whether a de minimis exception applies.

1101.4 De Minimis – The following may be representative de minimis exception examples:

- (1) Common area lighting fixtures up to two (2) 100-watt light bulbs operating 24 hours/day, seven days per week
- (2) Common area outlets without constant motor loads, such as an outlet in a hallway used for housekeeping
- (3) Common area garage door opener for non-commercial use.
- (4) Mixed wiring with another tenant unit
- (5) Laundry appliances accessible by multiple tenants
- (6) Common area lighting fixtures exceeding two (2) 100-watt light bulbs operating 24 hours/day, seven days per week usage

A landlord seeking to prove a de minimis exception shall do so by providing evidence establishing by actual measurement that the usage does not exceed 1,752 kilowatt hours per year. Where such actual measurement is not possible the landlord shall present written documentation from a licensed tradesperson or housing inspector that this usage is not likely to exceed 1,752 kilowatt hours per year. Such evidence must be presented prior to, during, or within 30 days of the conclusion of a shared meter investigation.

1101.5 Adjustments – Upon discovery of a single-metered residential building, as defined pursuant to Minnesota Statute Section 504B.215, whether shared metering, mixed wiring or mixed plumbing in which individual metered service had been established and billed, KPU shall, within thirty (30) business days, recognize and make adjustments to its records to reflect that the landlord/building owner is the bill payer responsible and customer of record. KPU shall make adjustments to the tenants and landlord/building owners account based on Minnesota State Statute and KPUs standard practices. Additionally, the tenant or landlord/building owner may seek additional adjustment of charges or challenge KPU's finding of a shared meter situation by filing a complaint with the Minnesota Public Utilities Commission, or by court action. Upon request, KPU will provide to the tenant available billing history in relation to such additional actions. The Minnesota Public Utilities Commission has determined that regardless of how or by whom an investigation is initiated leading to utility account adjustments, credits and/or refunds as herein described, the investigation and any resulting adjustments, credits and/or refunds shall implicate the protections of Minnesota Statute Sections 504B.285 Subds. 2 and 3, and 504B.441.

In the event the landlord/building owner denies access to the building or fails to cooperate with an investigation to determine whether a single-metered residential building exists, as defined pursuant to Minnesota Statute Section

504B.215, the building shall be presumed to be a single-metered residential building as defined pursuant to Minnesota Statute Section 504B.215, and the landlord/building owner shall be the bill payer responsible and customer of record. KPU shall make adjustments to the tenants and landlord/building owners account based on Minnesota State Statute and KPU's standard practices. Additionally, the tenant or landlord/building owner may seek additional adjustment of charges or challenge KPU's finding of a shared meter situation by filing a complaint with the Minnesota Public Utilities Commission, or by court action. The Minnesota Public Utilities Commission has determined that regardless of how or by whom an investigation is initiated leading to utility account adjustments, credits and/or refunds as herein described, the investigation and any resulting adjustments, credits and/or refunds shall implicate the protections of Minnesota Statute Sections 504B.285 subds.2 and 3, and 504B.441.

1101.6 Service Re-establishment – In order to reestablish individual metered service for the individual tenant units, the landlord/building owner shall be required to provide certification of a licensed electrician that the building has been inspected sufficiently to determine that all instances of mixed wiring, shared metering and mixed plumbing have been eliminated or that the building qualifies for a de minimis exception, as shown by actual measurement or by certification by a licensed tradesperson or housing inspector. Additionally, the building owner may be required by KPU to post a deposit equal to the expected charges for up to two months of usage for electric service to the building.

KPU shall have the right to verify the certification at the landlord/building owner's expense prior to establishing metered service for individual units. Such verification shall not relieve the landlord/building owner of its responsibility to be the bill payer and customer of record of a single-metered residential building as defined pursuant to Minnesota Statute Section 504B.215.

1101.7 MN PUC Petition – In the event of discovery of a single-metered residential service, as defined pursuant to Minnesota Statute Section 504B.215, after previous certification to reestablish individual metered service for tenants, in addition to the above adjustments, the building shall be ineligible for individual metered service for tenants without petition to the Minnesota Public Utilities Commission by the landlord/building owner and a showing by the building owner by clear and convincing evidence justifying the reestablishment of individual metered service for tenants. Additionally, the MPUC may require consent of the building's tenants in determining that reestablishment of the individual metered service for tenants is appropriate.

1101.8 Series Metering – KPU will not install, operate, maintain, or acquire any series metering system. KPU may, however, require series subtractive

metering for its own purposes to measure consumption and render bills for electric energy not otherwise measured.

1101.9 Service Arrangement – Electricity is normally supplied to each separate customer through a single service and meter. KPU does not engage in the practice of doing interior wiring on customer's premises except for the installation and maintenance of its own property. The customer may combine the supply of electricity through one meter and one service to two or more buildings or occupancy units if they are located on the same or contiguous parcels of property and occupied by the same customer, solely for customer's own use. If separate buildings are occupied in whole or part by tenants of the customer, then each tenant occupied building, or area, or occupancy unit must be segregated from other loads of the customer and metered by KPU.

1101.10 Legacy Arrangement – If more than one building with tenants, or portions of more than one building with tenants, are served through one meter, this practice may continue until such time as material structural changes are made that will result in major modifications to the customer's service entrance equipment. If such modifications do occur, provisions must be made to allow for individual KPU metering of each tenant occupied building, or area, or occupancy unit. While the single meter service continues, the bill for the buildings will be computed as though each building used an equal portion of the total metered service and was separately billed.

1101.11 Customer Responsibility – All wiring and equipment on customer's side of the point of delivery, except metering equipment, will be furnished, installed, and maintained at the customer's expense in a manner approved by the public authorities having jurisdiction over the same. Customer will protect all electrical equipment and systems with devices that conform to the industry accepted standard for the various classes of electrical equipment and systems to prevent fire or damage to equipment from electrical disturbances or fault occurring in the customer's system or in the supplying system. The "industry accepted standard" will be as required in the National Electrical Code and such additional devices as are prescribed by any public authority with jurisdiction over the installation of electrical facilities.

1101.12 Inspections – Any inspection of a customer's wiring and equipment by KPU is for the purpose of avoiding unnecessary interruptions of service to its customers or damage to its property, and for no other purpose, and will not be construed to impose any liability upon KPU to a customer or any other person by reason thereof. In addition, KPU will not be liable or responsible for any loss, injury, or damage that may result from the use of or defects in a customer's wiring or equipment.

KPU may, however, at any time require a customer to make such changes in customer's electrical or non-electrical property or use thereof as may be necessary to eliminate any hazardous condition or any adverse effect which the operation of the customer's property or equipment may have on said customer, other customers of KPU, the public, or KPU's employees, equipment or service. In lieu of changes by the customer, KPU may require reimbursement from the customer for the cost incurred by KPU in alleviating an adverse effect on KPU's facilities caused by the customer's property.

1101.13 Capacity – The transformers, service conductors, meters, and appurtenances used in furnishing electric service to a customer have a definite capacity. Therefore, no material increase in load or equipment will be made without first making arrangements with KPU for the additional electric supply.

1102 RATE SCHEDULE CLASSIFICATION

Electric service is supplied to customers under various rate schedule classifications as determined by the type of service, the amount of electric power supplied, and the purpose for which the electric service is to be used. Copies of KPU's rate schedules are available at KPU's Service Center and www.cityofkasson.com.

1103 PAYMENT

1103.1 Meter Reading – KPU will, insofar as possible, read all meters every month and bill the customer for service used during the period. Payment of the bill is due by the date noted on the bill.

1103.2 Estimated Billing – If the meter cannot be read during a billing period, or the reading seems erroneous, an estimate will be made for that billing period. Adjustments to bills resulting from inaccuracies in the meters will be handled in the manner described in Section 608, Meter Testing.

1104 CUSTOMER CHARGE

There is a customer charge for each meter/service provided. The amount of this customer charge will vary based on the type and number of services provided (refer to KPU's rate schedule(s) for more information).

1105 NEW UNDERGROUND RESIDENTIAL SERVICE CONNECTION CHARGE

1105.1 Charges – KPU will charge an underground service connection charge (New Underground Service fee) for the extension and/or connection of new underground electrical service to any single-family home, townhome, condominium, duplex or triplex located in a R-1, R-1x, R-Sa, R-2, R-4 or Special District, zoning districts. The amount of the charge can be obtained from Utility Billing.

1105.2 Service Connections – There will be no charge for connections or reconnections of existing services, in good payment standing, during KPU's normal working hours. If connection must be made outside of normal working hours at the request of the customer, a special connection charge will be assessed. The charge for such work can be obtained from Utility Billing.

1106 SERVICE DISCONNECTION/RECONNECTION

1106.1 With Notice – KPU may disconnect a customer's service, with notice, for any of the following reasons:

- (1) Nonpayment of billings or issuance of non-negotiable check
- (2) Nonpayment of a deposit or other charges/fees
- (3) Failure to meet credit requirements
- (4) Failure to provide access to KPU owned metering equipment

1106.2 Without Notice – KPU may disconnect a customer's service, without notice, for any of the following reasons:

- (1) A condition determined to be hazardous – to the customer, to other customers, or to KPU personnel
- (2) Unauthorized use of electricity, water, or equipment belonging to KPU

1106.3 Reconnection Fee – In the event service has been disconnected for nonpayment, deposit, theft, or other credit cause, the customer will be required to pay a reconnection fee before the service is restored. In the event that the service is disconnected because of hazardous conditions on the customer owned equipment or unauthorized use, the customer will be required to have all required inspections performed prior to service being restored.

1106.4 Fee Schedule – A schedule of fees is available from KPU Utility Billing and on www.cityofkasson.com.

1107 SERVICE DEPOSIT

KPU has established a credit policy whereby existing customers with an acceptable credit history and customers never having had service with KPU may not be required to provide a deposit as a condition of service. A new or additional deposit may be required in cases where a deposit has been refunded or where the current deposit amount is inadequate. The deposit amount is based on two times the average monthly bill and bears interest at the rate established by Minnesota Statute Section 325E.02. Further information is available in the KPU Deposit Policy.

1108 SECURITY LIGHTING

Security lighting is available under its own rate schedule classification for those customers requesting it.

1109 POWER FACTOR CORRECTION CALCULATION

Refer to Table 11.1 on the following page for instructions for multipliers to determine required capacitor kVARs for correcting power factor

TABLE 11.1 – POWER FACTOR CORRECTION CALCULATION TABLE

ORIGINAL POWER FACTOR	CORRECTED POWER FACTOR						
	90%	92%	94%	95%	96%	98%	100%
60%	0.849	0.907	0.970	1.005	1.042	1.130	1.333
62%	0.781	0.839	0.903	0.937	0.974	1.062	1.265
64%	0.716	0.775	0.838	0.872	0.909	0.998	1.201
66%	0.654	0.712	0.775	0.81	0.847	0.935	1.138
68%	0.594	0.652	0.715	0.750	0.787	0.875	1.078
70%	0.536	0.594	0.657	0.692	0.729	0.817	1.020
72%	0.480	0.538	0.601	0.635	0.672	0.761	0.964
74%	0.425	0.483	0.546	0.580	0.617	0.706	0.909
76%	0.371	0.429	0.492	0.526	0.563	0.652	0.855
78%	0.318	0.376	0.439	0.474	0.511	0.599	0.802
80%	0.266	0.324	0.387	0.421	0.458	0.547	0.750
82%	0.214	0.272	0.335	0.369	0.406	0.495	0.698
84%	0.162	0.220	0.283	0.317	0.354	0.443	0.646
86%	0.109	0.167	0.230	0.265	0.302	0.390	0.593
88%	0.055	0.114	0.177	0.211	0.248	0.337	0.540
90%	0	0.058	0.121	0.156	0.193	0.281	0.484
92%		0	0.063	0.097	0.134	0.223	0.426
94%			0	0.034	0.071	0.160	0.363
96%					0	0.089	0.292
98%						0	0.203
100%							0

INSTRUCTIONS:

1. Determine the average power factor that your system operates at during peak demand months. Call this your ORIGINAL POWER FACTOR.
2. In the row titled CORRECTED POWER FACTOR at the top of the page, find the power factor that you wish to correct your system to.
3. Read from left to right along the row corresponding to your ORIGINAL POWER FACTOR until you reach the column that shows your desired CORRECTED POWER FACTOR.
4. Read the number that you find at the intersection of the row and column. Multiply your KW Demand by this number to calculate the total amount of capacitor KVAR you need to install to your electric service.
5. If your plant operates with a 3 phase electric service, divide the total KVAR by 3 to determine the amount of KVAR to connect per phase.

Example: If your plant has a 3 phase demand of 410 KW and operates at 76% power factor, but you want to correct to 95%:

- a) Find 95% in the CORRECTED POWER FACTOR row at the top of the page
- b) Find 76% in the ORIGINAL POWER FACTOR column along the left edge of the page. Read from left to right along this row until you reach the 95% column
- c) Read the number at the intersection of the row and column (0.526)
 $410 \text{ KW} \times 0.526 = 216 \text{ KVAR}$ needed to correct your system to 95% power factor
- d) $216 \div 3 = 72 \text{ KVAR}$ per phase

SECTION 1200 – EXHIBIT DRAWINGS & INFORMATION

EXHIBIT

- 1 Typical Underground Residential Metering Arrangement
- 2 Typical Mobile Home Metering Arrangement
- 3 Typical Multiple Metering Arrangement
- 4 Service Conductor Clearances (480V and below)
 - 4.1 Service Conductor Clearances from Balconies & Windows
 - 4.2 Secondary Conductor Clearances over Roofs
 - 4.3 Service Conductor Clearances to Patios and Pools
 - 4.4 Service Conductor Clearances to Aboveground Swimming Pool With Deck
 - 4.5 Service Conductor Clearances to Aboveground Swimming Pool Without Deck
- 5 Overhead Supply Secondary Temporary Service Installation
- 6 Typical Residential Service Mast Installation with Guying
 - 6.1 Typical Residential Under Eaves Service Installation
- 7 Clearance Requirements of Pad-Mounted Transformers
 - 7.1 Transformer Bollard Detail
- 8 KPU and Customer Responsibilities Associated with Non-Single Family Underground Installations
- 9 KPU and Customer Responsibilities Associated with Underground Single Family Residential Distribution (URD) Installations
- 10 Installation Guidelines
- 11 Meter Socket Types
 - 11.1 Required Meter Working and Safety Clearances