



PERSHING COUNTY BUILDING DEPARTMENT BUILDING GUIDE

Single Family Residential Basement

Building Guide

How to use this guide:

At least three completed documents must be provided to apply for a building permit:

1. Complete this guide by filling in the blanks on page three, indicating which construction details will be used. Please print legibly.
2. Provide a separate site plan showing dimensions of your project or addition and its relationship to the existing building or structures on the property. Show all easements and the distance to existing property lines.
3. Provide a floorplan.
4. Envelope compliance forms to meet IECC 2018. This is a summary of your wall, window, and door areas and insulation values.
5. Fill out a building permit application.

The majority of permit applications are processed with little delay. The submitted documents will help determine if the project is in compliance with building safety codes, zoning ordinances, and other applicable laws.

Basement Finish Requirements

1. **Ceiling Heights:** If the finished ceiling will be less than 7'-6", please consult the Building Department.
2. **Emergency Escapes:** All sleeping rooms must have an egress window or exterior door. Emergency escape windows with a sill height below grade must be provided with an egress window well. For egress window and window well requirements, see Detail A & Detail B on Page 3 of this handout.
3. **Smoke Detectors:** Smoke detectors are required in all basements. If the finished basement contains a sleeping room, a smoke detector must be installed on the ceiling or wall in the sleeping room and in the hallway or area immediately outside of the sleeping room. Smoke detectors added to satisfy the above requirements must be hard-wired with battery backup and interconnected with existing smoke detectors. If interior remodel work exceeds \$1,000 in valuation, battery smoke detectors must be added to bedrooms and common hallways in existing portions of the house.
4. **Fuel Burning Appliances:** Furnaces and water heaters cannot be located in or accessed through a bedroom or bathroom. If the furnace and water heater are being enclosed, adequate combustion air must be provided for these appliances to operate properly. For maintenance purposes, a minimum of 30" clear working space must be provided in front of furnaces and water heaters. Maintenance or removal of each appliance must be possible without removing the other or disturbing walls, piping, valves, wiring, and junction boxes.
5. **Floated Walls:** In areas subject to floor heaving, non-bearing walls on basement floor slabs should be built to accommodate not less than 1-1/2" of floor movement. A detail of a typical floated wall is included on page 3, Detail C, of this handout. Drywall should be held to a minimum of 1" above the slab to allow for movement.
6. **Firestopping:** Firestopping must be installed in concealed spaces of wood-furred walls at the ceiling level, at 10-foot intervals along the length of the wall and at all interconnections of concealed vertical and horizontal spaces, such as intersection of stud walls and soffits, or dropped ceilings. A detail of typical firestopping is included on Page 3, Detail C. Firestops may be constructed of 1-1/2" lumber, 3/4" plywood or particleboard, gypsum board, or fiberglass insulation.
7. **Insulation:** Check with the Building Department for insulation requirements.
8. **Space Under Stairs:** If access to the area or space under the basement stairs is provided for storage or other uses, the walls and ceiling of this enclosed space must be fire-protected on the inside with 5/8" Type-X drywall.
9. **Bathrooms:** Toilets must be provided with a minimum of 24" in front of the toilet and 15" between the center of the toilet and any sidewall or other obstruction. Showers shall have a minimum inside dimension of 1,024 square inches, capable of encompassing a 30" circle and be finished 70" above the drain with non-absorbent materials. Note: These measurements are not acceptable for accessible restrooms for the disabled. A ventilation fan is required in bathrooms and toilet rooms with unopenable windows. The fan must be vented to the exterior of the building if the bathroom has a tub or shower.
10. **Lighting and Ventilation:** Lighting and ventilation are required for any finished portion of the basement. Contact the Building Department for specific requirements.

The Building Department staff can help you determine what is necessary to meet minimum safety requirements.



PERSHING COUNTY BUILDING
DEPARTMENT BUILDING GUIDE

Single Family Residential Basement

Floor Plan

Property Address _____

Permit # _____

Directions

1. Draw a floor plan with dimensions, showing the layout of the entire basement.
2. Label the use for all the rooms.
3. Show electrical outlets, smoke detectors, lighting, fans, plumbing modifications, cleanouts, furnace, and water heater.
4. List window and door sizes and types. Identify emergency escape, rescue windows, and egress window wells.
5. Identify modifications to the existing structure such as posts, beams, and floor joists.



PERSHING COUNTY BUILDING DEPARTMENT BUILDING GUIDE

Single Family Residential Basement

Basement Finish Details

Detail A - Egress Window Well

Egress window wells must provide a minimum area of nine square feet, with a minimum dimension of 36", and shall enable the window to open full. If the depth of the window well exceeds 44", a permanently affixed ladder must be provided. The ladder must not interfere with the operation of the window.

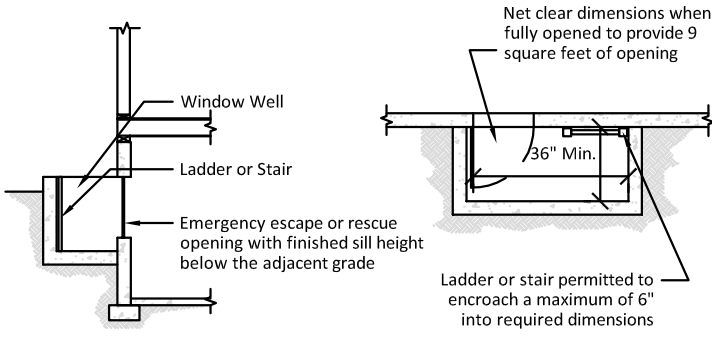

Detail B - Emergency Escape & Rescue Window

Emergency Escape and Rescue Windows must meet the following criteria:

1. A minimum total openable area of not less than 5.7 square feet
2. A minimum clear openable height of not less than 24"
3. A minimum clear openable width of not less than 20"
4. A finished sill height of not more than 44" above the floor and should be openable from the inside without the use of separate tools, knowledge, or effort.

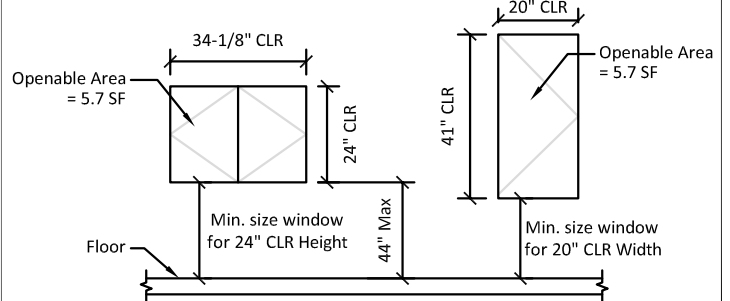

Detail C - Firestop and Floating Wall

