



AGENDA

PINE COUNTY BOARD OF COMMISSIONERS ORGANIZATIONAL and REGULAR MEETING

District 1	Commissioner Hallan
District 2	Commissioner Mohr
District 3	Commissioner Lovgren
District 4	Commissioner Waldhalm
District 5	Commissioner Ludwig

Tuesday, January 5, 2021, 10:00 a.m.
Board Room, Pine County Courthouse
635 Northridge Drive NW
Pine City, Minnesota

- **The Meeting Will be In Person and Via WebEx (video / phone conference) and streamed live on the internet.**
- **Not more than two county commissioners will be present in the meeting room.**
- **The public may join the meeting via WebEx, in person at the meeting room, or watch the livestream.**
- **If joining the meeting in person, the total number of persons (including commissioners) cannot exceed 10 and social distancing of at least 6 feet will be in effect.**

The Governor of the State of Minnesota has issued Executive Order 20-01 Declaring a Peacetime Emergency and Coordinating Minnesota's Strategy to Protect Minnesotans from COVID-19. On March 24, 2020 the Pine County Board of Commissioners declared a local emergency for Pine County.

Based on these conditions, the Pine County Administrator has determined that the requirements of Minnesota Statute 13D.021, Subd. (1) have been met and it is not practical or prudent for all members of the county board to meet in person.

The public is invited to join the meeting in person or remotely: by phone call 1-650-215-5226, (access code): 175 248 6128, (password): wAbS62TEng3. Click the link on the county website (www.co.pine.mn.us) for more information and to watch a live stream broadcast of the meeting.

- A) Call meeting to order (County Administrator)
- B) Pledge of Allegiance
- C) Election of County Board Chair and Vice-Chair for 2021
- D) Public Forum. Members of the public are invited to speak. After being recognized by the Chair, each speaker should state his/her name and limit comments to three (3) minutes.
- E) Adopt Agenda
- F) 2021 Committee Assignments and other appointments

- G) 2021 County Board Schedule
- H) Approve Minutes of December 15, 2020 County Board Meeting and Summary for publication.
- I) Minutes of Boards, Committees and Correspondence
 - Pine County Chemical Health Coalition Minutes – December 14, 2020
 - Pine County Land Surveyor Monthly Report – December, 2020
- J) Approve Consent Items

CONSENT AGENDA

The consent agenda is voted on without any discussion. Any commissioner may request an item be removed and added to the regular agenda.

1. Donations

- A. Consider acceptance of a \$500 donation from Atscott Manufacturing for the annual Pine County Sheriff’s Office Toy Drive.

2. Contracts

Consider approval of the following contracts and authorize Board Chair and County Administrator to sign:

A. Soil & Water Conservation District (SWCD) Administrative Support Contract

Provide temporary administrative support to the Soil & Water Conservation District by the County Zoning Department. The county shall bill SWCD for work performed at the rate of \$26 per hour which shall apply to time worked by county staff and include travel time, if necessary. The term of the contract is January 5, 2021 through December 31, 2021.

B. Rise Up Psychological Services Contract

Between Rise Up Psychological Services and Pine County Health & Human Services (HHS) for Rise Up Psychological Services to provide clinical supervision to HHS’s children’s mental health case managers at a rate of \$125 per hour (three hours per month; \$4,500/year), and reflective practice supervision to HHS staff including public health family home visiting staff and child protection staff, at a rate of \$100 per hour (maximum of \$15,600/year). The term of the contract will be January 1, 2021 through December 31, 2021.

C. Medication Management Services

Between Kanabec County Family Services (KCFS) and Pine County Health & Human Services (HHS) for KCFS to provide medication management services. The term of the contract is January 1, 2021 through December 31, 2021. The rate is \$128.64 per hour, not to exceed \$10,805 annually.

D. Solid Oak Financial Services

Between Solid Oak Financial Services and Pine County Health & Human Services to provide guardianship services to adults who need a guardian. The term of the contract is January 1, 2021 through December 31, 2021. The cost of the service is increasing from \$130/month per individual to \$155/month per individual.

3. Septic Fix-Up Special Assessment

Consider approval of Resolution 2021-01 extending septic fix-up special assessments as follows:

- A. Paul E. Jerry, PID 17.0256.000, \$13,280
- B. Shawn Kilpela and Stacie Mix, PID 43.0552.000, \$11,496.21

- C. Ralph O. Baker and Gloria J. Baker, PID 26.0049.000, \$5,750
 - D. Michael T. Belland and Michelle M. Belland, PID 26.8800.300, \$5,750
 - E. Clifford McCann, PID 31.0020.001, \$15,800
 - F. Kevin W. Dahl and Paula K. Dahl, PID 43.0608.001, \$24,500
- Authorize Board Chair and County Administrator to sign.

4. Final Payment Contract #1901

Consider approval of final payment to S. R. Reinforcing Inc. in the amount of \$33,066.93 for Contract #1901 related to SAP 058-632-018 / Bridge #58557 on CSAH 32, 2.4 miles Northwest of CSAH 31 over Hay Creek, and authorize County Administrator to sign the Certificate of Final Contract Acceptance.

5. Training

A. Consider approval of Jacqueline Ness, Clerk III in the Auditor-Treasurer's Office, to attend the virtual Pro-West Legal Description Training hosted by the Minnesota Counties Computer Cooperative. Registration: \$180; no travel expenses. Funds are available within the 2021 Auditor-Treasurer's Office budget.

REGULAR AGENDA

1. Recognition of 50 Years of County Employment

Acknowledge Office Manager Janet Schumacher's 50 years of employment with Pine County Health & Human Services.

2. Introduction to Soil & Water Conservation District Interim District Manager

Introduction of Paul Swanson, District Forester who will be acting as the SWCD Interim District Manager for a six-month period.

3. U of M Extension / Ag Educator Program Update

Presentation by Pine County Extension Ag Educator Rod Greder, U of M Extension Program Leader Nathan Winter, and U of M Extension Regional Director Susanne Hinrichs.

4. Property Clean-Up Special Assessment

Consider approval of Resolution 2021-02 extending a special assessment for parcel 28.0520.005 for \$28,500 for a term of 20 years at 0% interest. Authorize Board Chair and County Administrator to sign.

5. Proposed 2021 Legislative Priorities – Arrowhead Counties Association

Discussion and direction as to the county's legislative priorities.

6. Request for Bids for Official Publication for 2021

Award bid.

7. Labor Negotiations Update

A. Consider approval of Labor Agreement with the Social Services Supervisors with the terms as stated subject to final drafting by the County Administrator. Authorize Board Chair and County Administrator to sign.

B. Consider approval of Labor Agreement with the Deputies with the terms as stated subject to final drafting by the County Administrator. Authorize Board Chair and County Administrator to sign.

Recess Regular Board meeting and Convene Rail Authority meeting.

8. Pine County Regional Railroad Authority Annual Meeting

Appoint Chair, Vice Chair, Secretary and Treasurer

(2020 appointments were Chair: Steve Hallan; Vice Chair: Josh Mohr;

Secretary: County Administrator David Minke/non-voting; and Treasurer: Auditor/Treasurer Kelly Schroeder/non-voting)

Discussion of Regional Rail Authority business (if any).

Adjourn Rail meeting and Reconvene County Board meeting.

9. Coronavirus Response Update

A. Public Health Update

B. State Business Relief Program Update

10. Commissioner Updates

Welding/Business Computer/Auto Tech Workfast PTCC Graduations

Arrowhead Counties Association: Cancelled

East Central Regional Development Commission (ECRDC)

ECRDC Legislative Roundtable

NLX: Cancelled

Pine County Housing and Redevelopment Authority telephone conference

Other

11. Other

12. Upcoming Meetings (Subject to Change) – All meetings to be conducted remotely unless otherwise indicated. Contact the organization hosting the meeting for call-in information.

- a. **Pine County Organizational and Regular Board Meeting, Tuesday, January 5, 2021, 10:00 a.m.**, Board Room, Courthouse, Pine City, Minnesota.
- b. **Facilities Committee, Wednesday, January 6, 2021, 9:00 a.m.**
- c. **Central MN Council on Aging/Board of Directors, Thursday, January 7, 2021, 10:00 a.m.**
- d. **Personnel Committee, Monday, January 11, 2021, 9:00 a.m.**
- e. **East Central Regional Library Trustee Board, Monday, January 11, 2021, 10:00 a.m.**
- f. **Special Meeting-Strategic Planning, Tuesday, January 12, 2021, 10:30 a.m.**
- g. **Soil & Water Conservation District, Tuesday, January 12, 2021, 2:00 p.m.**
- h. **Pine County Board Meeting, Tuesday, January 19, 2021, 10:00 a.m.**, North Pine Government Center, 1602 Hwy. 23 No., Sandstone, Minnesota.

13. Adjourn

2021 Board and Committee Appointments

OUTSIDE BOARDS AND COMMITTEES	2020 Representative	2020 Alternate	2021 Representative	2021 Alternate
AMC Committee – Environment & Natural Resources	Mohr			
AMC Committee – General Government	Mikrot			
AMC Committee – Health & Human Services	Chaffee			
AMC Committee – Public Safety Policy Committee	Ludwig			
AMC Committee – Transportation & Infrastructure	Hallan			
AMC Committee – Indian Affairs Advisory Council	Hallan	Chaffee		
AMC Delegate Appointments (county is authorized 1 delegate for each commissioner and three additional delegates)	Hallan, Mohr, Chaffee, Mikrot, Ludwig, LeBrun, Foss, Minke			
1W1P Policy Committee – Lower St. Croix	Hallan	Mohr		
1W1P Policy Committee - Nemadji	Ludwig	Mikrot		
1W1P Policy Committee - Snake River (new for 2021)				
1W1P Technical Committee – Lower St. Croix 1W1P Technical Committee - Nemadji 1W1P Technical Committee - Snake River (new for 2021)	Land and Resources Manager Caleb Anderson			
Arrowhead Counties Association (ACA)	All	Ludwig		
Association of Minnesota Counties (AMC)	All			
Central MN Jobs and Training Service	Hallan	Ludwig		
Central Regional EMS Committee	Ludwig	Mikrot		
East Central Regional Development Commission (ECRDC)	Mikrot	Hallan		
East Central Regional Juvenile Center (ECRJC) Advisory Committee	Ludwig	Mikrot		
East Central Regional Library	Mohr	Chaffee		
East Central Solid Waste Commission (ECSWC)	Hallan	Ludwig		
Extension Committee	Chaffee/Mohr			
Fiber-Optic Joint Power Board	Hallan	Mohr		
GPS 45:93 Joint Powers Board	County Administrator	Hallan		
Greater Minnesota Parks and Trails (GMPT)	Mikrot	All		
Lakes and Pines Community Action Council (CAC)	Hallan	Mikrot		
Law Library	Mohr	Chaffee		
Minnesota Counties Intergovernmental Trust (MCIT)	Minke, Hallan			
Minnesota Rural Counties (MRC)	Hallan	All		

Northeast Minnesota Area Transportation Partnership	Hallan	Mikrot		
Northeast Minnesota Regional Emergency Communications Board	Hallan	Chief Deputy Paul Widenstrom		
Northeast Minnesota Regional Advisory Committee (RAC)	Sheriff Jeff Nelson			
NLX	Ludwig	Chaffee		
Rush Line Corridor Task Force	Mikrot	Mohr		
Snake River Watershed Joint Powers Board	Mohr	Hallan		
Soil & Water Conservation District Liaison	Ludwig	Mohr		
State Community Health Services Advisory Committee (SCHSAC)	Chaffee	Community Health Services Administrator Samantha Lo		
COUNTY ESTABLISHED COMMITTEES	2020 Appointment	2020 Alternate	2021 Appointment	2021 Alternate
Canvassing Board (NEW for 2021)	Hallan/Ludwig	Mohr		
Economic Development	Mikrot/Mohr			
Facilities Committee	Ludwig/Mohr			
Government Operations	Ludwig/Mikrot			
Health & Human Services	Hallan/Chaffee			
Insurance Committee	Hallan/Ludwig			
Finance and Investment Committee (new name in 2021)	Ludwig/Hallan			
Land/Zoning Advisory Committee *Liaison to Planning Commission	Chaffee/Ludwig*			
Mille Lacs Band of Ojibwe Liaison	Hallan/Chaffee			
Negotiations (Labor Relations) Committee	Chaffee/Mohr			
Personnel Committee	Chaffee/Ludwig	Mohr		
Pine County Chemical Health Coalition	Ludwig/Mikrot			
Public Safety Committee	Hallan/Ludwig			
Technology Committee	Hallan/Mohr			
Transportation Committee	Hallan/Mikrot			
Equal Employment Opportunity Coordinator required by section 3.2 of the County Policy and Procedure Manual	Jackie Koivisto			

WORKING DRAFT
TO BE CONSIDERED FOR ADOPTION AT ITS
JANUARY 5, 2021 MEETING

2021 Pine County Board of Commissioner Meeting Schedule

- Regular meetings of the Pine County Board of commissioners are at 10:00 a.m. on the first and third Tuesday's of the month except for December when the first meeting of the month will be held Thursday, December 9, 2021. Due to the pandemic, and as allowed by Minnesota Statutes 13D, regular meetings will be conducted in person and via electronic means. The in-person portion of the meeting will be held at the North Pine Government Center 1602 Hwy 23 N. Sandstone. Information to join electronically will be posted on the county web site.
- The meetings on the first Tuesday of the month begin at 10:00 a.m. and are held at the Pine County Courthouse, Boardroom, Pine City;
- The meetings on the third Tuesday of the month begin at 10:00 a.m. and are held at the North Pine Government Center, 1602 Hwy 23 No., Sandstone, unless otherwise noted:

Projected dates if 1st & 3rd Tuesdays:

January 5th and 19th

February 2nd and 16th

March 2nd and 16th

April 6th and 20th

May 4th and 18th

June 1st and 15th

July 6th and 20th

August 3rd and 17th

September 7th and 21st

October 5th and 19th

November 2nd and 16th

December 9th (This change of date is due to the Association of Minnesota Counties Annual Conference scheduled for December 6-8, 2021) and 21st

Board of Equalization, June 14, 2021 at 6:00 p.m., Pine County Courthouse, Boardroom, Pine City.

Truth in Taxation, December 9, 2021, at 6:00 p.m., Pine County Courthouse, Boardroom, Pine City. This meeting is required by MS 275.065 and must be held between November 25 and December 30. The meeting may not start before 6:00 PM.

County Board Committee Meetings

Facilities 1st Wednesday -- 9:00 a.m.

HHS February 8, May 10, August 9, November 8 – 10:30 a.m.

Personnel Monday of the week prior to the 2nd board meeting -- 9:00 a.m.

Technology 4th Tuesday of odd numbered months (January, March, May, July, September, November)– 9:00 a.m.

**MINUTES
OF THE
PINE COUNTY BOARD MEETING
Regular Meeting**

**Tuesday, December 15, 2020 - 10:00 a.m.
North Pine Government Center, Sandstone, Minnesota**

Chair Steve Hallan called the meeting to order at 10:00 a.m.

Chair Hallan stated the Governor of the State of Minnesota has issued Executive Order 20-01 Declaring a Peacetime Emergency and Coordinating Minnesota's Strategy to Protect Minnesotans from COVID-19. On March 24, 2020, the Pine County Board of Commissioners declared a local emergency for Pine County.

Based on these conditions, the Chair of the Pine County Board of Commissioners has determined that the requirements of Minnesota Statute 13D.021, Subd. (1) have been met and it is not practical or prudent for all members of the county board to meet in person. Members of the county board will join the meeting remotely.

The public was invited to join the meeting remotely by phone, WebEx or watch via live stream on YouTube.

Commissioner John Mikrot and Commissioner Matt Ludwig were present in the meeting room. Members present via electronic means were Chair Hallan, Commissioner Josh Mohr and Commissioner Steve Chaffee. Also present in the meeting room was County Administrator David Minke and present via electronic means was County Attorney Reese Frederickson.

The Pledge of Allegiance was said.

Chair Hallan called for public comment. There was no public comment.

Chair Hallan requested the following revisions to the agenda:

Addition to Consent Agenda Item 11 (New Hire)

C. Consider approval of the hiring of Jacqueline Ness, Clerk III, effective January 11, 2021, \$17.66 per hour, Grade 4.

Addition to Regular Agenda Item 8 (Labor Negotiations Update)

8C & 8D Consider approval of labor agreements with the Highway Supervisors, and Legal Assistants, with the terms as stated subject to final drafting by the County Administrator.

Motion by Commissioner Ludwig to adopt the amended Agenda. Second by Commissioner Mikrot. A Roll Call vote was called by Chair Hallan: District 5-Commissioner Ludwig/Aye; District 1-Chair Hallan/Aye; District 2-Commissioner Mohr/Aye; District 3-Commissioner Chaffee/Aye; District 4-Commissioner Mikrot/Aye. Motion carried 5-0.

Motion by Commissioner Mohr to approve the Minutes of the December 1, 2020 county board meeting and Summary for publication, and the December 3, 2020 Truth in Taxation Minutes. Second by Commissioner Chaffee. A Roll Call vote was called by Chair Hallan: District 1-Chair Hallan/Aye; District 2-Commissioner Mohr/Aye; District 3-Commissioner Chaffee/Aye; District 4-Commissioner Mikrot/Aye; District 5-Commissioner Ludwig/Aye. Motion carried 5-0.

Minutes of Boards, Reports and Correspondence

City of Sandstone Wellhead Protection Plan, Part Two

Pine County Housing and Redevelopment Authority Board of Directors Regular Meeting –
October 28, 2020

Pine County Land Surveyor Monthly Report – November 2020

Motion by Commissioner Mikrot to acknowledge the Minutes of Boards, Reports and Correspondence. Second by Commissioner Mohr. A Roll Call vote was called by Chair Hallan: District 2-Commissioner Mohr/Aye; District 3-Commissioner Chaffee/Aye; District 4-Commissioner Mikrot/Aye; District 5-Commissioner Ludwig/Aye; District 1-Chair Hallan/Aye. Motion carried 5-0.

Motion by Commissioner Ludwig to approve the amended Consent Agenda. Second by Commissioner Mikrot. A Roll Call vote was called by Chair Hallan: District 3-Commissioner Chaffee/Aye; District 4-Commissioner Mikrot/Aye; District 5-Commissioner Ludwig/Aye; District 1-Chair Hallan/Aye; District 2-Commissioner Mohr/Aye. Motion carried 5-0.

CONSENT AGENDA

1. **Approve November, 2020 Cash Balance**

Fund	November 30, 2019	November 30, 2020	Increase/Decrease
General Fund	6,366,268	7,301,820	935,552
Health and Human Services Fund	1,890,981	2,652,111	761,130
Road and Bridge Fund	3,593,725	2,255,127	(1,338,598)
CARES Act	0	750,997	750,997
Land Management Fund	2,127,760	2,331,066	203,307
TOTAL (inc non-major funds)	16,445,846	18,219,099	1,773,253

2. **November 2020 Disbursements/Claims Over \$2,000**

Approve the November 2020 disbursements and claims over \$2,000.

3. **Licenses**

Approve the following licenses 2021 Waste Hauler Licenses and authorize Board Chair to sign: Cloquet Sanitary Service; Hartl Enterprises, LLC DBA Ron’s Rolloffs; Jim’s Mille Lacs Disposal, Inc; Jones Construction Services; LePage & Sons Inc; Pine Habitation and Supported Employment, Inc (PHASE); Mike’s Sanitation Inc; Nordstrom’s Sanitation, LLC; Waste Management.

4. **Donations**

Accept an anonymous \$750 donation to be designated as follows: \$250/Shop with a Cop program; \$250/Benjamin Neel Gun Range; \$250/K-9 program.

5. **2020 Budget Adjustment**

Approve the 2020 budget adjustments and recognition of spending of reserves as follows:

General Fund

Department	Account	Account Description	Change
County Recorder	01.101.5506	Recorder Technology Fee	from \$80,000 to \$95,000
County Recorder	01.101.6666	Recorder Technology Expense	from \$80,000 to \$95,000

Revenues and expenses have both exceeded budget. Expenses were intentionally spent at a higher rate than budget to spend down the restricted reserve balance; however, this year revenues were higher than expected and have matched the spending.

Department	Account	Account Description	Change
County Recorder	01.101.5522	Recorder Compliance Fee	from \$73,000 to \$120,000
County Recorder	01.101.6667	Recorder Compliance Expense	from \$73,000 to \$120,000

Refunds from the County's Member Deposit at MCCC were issued due to the new TAX/CAMA system not moving forward. These funds were originally paid from the Compliance fund, so they were deposited back into the fund. The increased expense is the intentionally spending down of these restricted reserves.

Department	Account	Account Description	Change
County Recorder	01.101.5504	Recorder Fees	from \$145,000 to \$160,000
County Assessor	01.105.6103	Salaries & Wages - Permanent	from \$397,721 to \$412,721

To account for higher than expected Recorder revenues and higher than expected Assessor salaries due to the unbudgeted Clerk position added to the Assessor's office in March 2020.

Department	Account	Account Description	Change
Planning & Zoning	01.107.5101	Zoning Permits	from \$62,000 to \$77,000
Planning & Zoning	01.107.6103	Salaries & Wages - Permanent	from \$154,251 to \$169,251

To account for higher than expected permit revenues and higher than expected Zoning salaries due to the unbudgeted Office Assistant position added to the office in August 2020.

Department	Account	Account Description	Change
County Sheriff	01.201.5230	State Grants	from \$250,000 to \$270,000
Dispatch	01.204.6103	Salaries & Wages - Permanent	from \$479,425 to \$389,425
Dispatch	01.204.6103	Salaries & Wages - Part time	from \$99,004 to \$79,004

County Sheriff	01.201.6107	Salaries & Wages - Overtime	from \$100,000 to \$230,000
----------------	-------------	--------------------------------	--------------------------------

To account for increased grant revenue, lower expenses in dispatch due to staff turnover and increased patrol overtime expenses.

Department	Account	Account Description	Change
Gun Permits	01.210.5101	Gun Permit Fees	from \$45,448 to \$62,448
Gun Permits	01.210.6103	Salaries & Wages - Permanent	from \$0 to \$17,000

Revenues and expenses have both exceeded budget. Expenses were intentionally spent at a higher rate than budget to spend down the restricted reserve balance; however, this year revenues were higher than expected and have matched the spending.

Department	Account	Account Description	Change
Solid Waste	01.392.5519	Fees for Service - Pine City	from \$10,000 to \$27,000
Solid Waste	01.392.5524	Fees for Service - Willow River	from \$30,000 to \$63,000
Solid Waste	01.392.5806	Refunds & Reimbursements	from \$8,000 to \$18,000
Solid Waste	01.392.6802	Transfer Station Refuse Removal	from \$45,000 to \$105,000

To account for increased revenue and expenses within the transfer stations.

Department	Account	Account Description	Change
Non-Departmental	01.801.6179	Worker's Compensation Premium	from \$110,000 to \$145,000
County Jail	01.251.6275	Medical Services - Prisoners	from \$428,300 to \$393,300

To account for higher than budgeted worker's compensation premium but lower than budgets medical services in the jail.

Department	Account	Account Description	Change
Medical Examiner	01.249.6263	Transport Fee Autopsies	from \$12,000 to \$14,500
Non-Departmental	01.801.5714	Interest Income	from \$180,000 to \$80,000
Court Security	01.253.6103	Salaries & Wages - Part time	from \$130,844 to \$42,844
Court Security	01.253.6103	Salaries & Wages - PERA	from \$13,995 to \$6,495
Court Security	01.253.6103	Salaries & Wages - FICA	from \$14,275 to \$7,275

To account for increased autopsy transport fees, decreased interest income due to low interest rates, decreased court security due to the court schedule (virtual).

HEALTH & HUMAN SERVICES - 12

Department	Account	Account Description	Change
Adult Protection Grant	12.430.761.3930.6020	General Case Mgmt/Guardianship	from \$10,809 to \$0
Adult Protection Grant	12.430.761.3042.6020	Assessment & Investigation	from \$0 to \$1,000
Adult Protection Grant	12.430.761.3160.6020	Transportation	from \$0 to \$2,000
Adult Protection Grant	12.430.761.3480.6020	Money Management	from \$0 to \$2,500
Adult Protection Grant	12.430.761.3714.6020	Adult Shelter	from \$0 to \$2,500
Adult Protection Grant	12.430.761.0010.6331	Staff Development	from \$0 to \$2,809

To account for grant expenses in their correct line items.

ROAD & BRIDGE - 13

Department	Account	Account Description	Change
Engineering/Construction	13.320.6263	Professional & Technical Services	from \$100,000 to \$285,000
Engineering/Construction	13.320.6283	Construction R & B	from \$4,550,000 to \$5,475,000
Non-Departmental	13.801.5203	State Aid - Reg. Construction	from \$2,700,000 to \$3,200,000
Non-Departmental	13.801.5310	Municipal Construction	from \$740,000 to \$1,350,000

To account for actual project costs and revenues.

Land - 22

Department	Account	Account Description	Change
Forest Roads	22.705.5390	Road Maintenance Aid	from \$0 to \$4,000
Forest Roads	22.705.6341	Road Construction/Maint	from \$7,200 to \$11,200

To account for increased revenue/expenses for forest road maintenance.

County Board acknowledges the following spending of reserves:

General Fund, Dept 107 - Zoning, Low Income Septic Fund - \$72,947.61
 General Fund, Dept 214 - Benjamin Neel Gun Range - \$8,855.80
 Technology Fund, \$142,660 (squad and body camera project)

6. **Violent Crime Enforcement Teams Grant Contract Agreement Amendment**
Approve an amendment to the Violent Crime Enforcement Teams 2020 Grant. This grant has been amended to allow for funding of \$150,000 through December 31, 2021. Authorize Board Chair and County Administrator to sign.

7. **Septic Fix-Up Special Assessments**
Approve Resolution 2020-80 extending a septic fix up special assessment to Jeannette P. Carmichael, PID 29.0357.000, \$20,250 and Robert Stauffer, PID 43.0358.000, \$17,450. Authorize Board Chair and County Administrator to sign.

8. **Contracts / Agreements**
Approve the following contracts/agreements and authorize Board Chair and County Administrator to sign:
 - A. **Pine County Health & Human Services and Jennifer N. White**
Clinical supervision services to adult mental health case managers. The rate is \$125 per hour, which is an increase of \$5/hour. The annual maximum cost for this service is \$6,000. One year contract (January 1, 2021 – December 31, 2021)
 - B. **Pine County Health & Human Services and Therapeutic Services Agency (TSA) 2021 Lead County Agreement**
TSA licenses therapeutic foster homes in the region; Pine County HHS historically serves as the county agency charged with negotiating a lead county agreement as TSA works with multiple agencies but its central office is in Pine City. Most rates have remained unchanged from 2020. One year contract (January 1, 2021 – December 31, 2021)
 - C. **Pine County Health & Human Services and Lighthouse Child and Family Services**
This contract provides for community support program services to eligible adults, and provides client outreach, medication monitoring, assistance in developing independent living skills, crisis assistance, housing support, social support, etc. Services not to exceed \$78,000 annually, which is the same amount as 2020. One year contract (January 1, 2021 - December 31, 2021)

9. **Designate Polling Places**
Approve Resolution 2020-81 declaring East Central Public School, Finlayson Elementary School, Hinckley-Finlayson High School, and Pine City High School as designated polling places for independent school district elections held in 2021. Authorize Board Chair and County Administrator to sign.

10. **2020 Assessment Clerical Corrections List**
Acknowledge list of 2020 assessment clerical corrections.

11. **New Hire**
Approve the hiring of the following:
 - A. Part-time dispatchers Jasmine Ploub and Marcus Hamilton-Gustafson, effective January 14, 2021, \$21.34 per hour, Grade 7, Step 1.
 - B. Part-time recycling center attendant James Laposky, effective December 16, 2020, \$14.62 per hour, non-union, Grade 1.
 - C. Jacqueline Ness, Clerk III, effective January 11, 2021, \$17.66 per hour, Grade 4.

REGULAR AGENDA

1. **Public Hearing – Unmanned Aerial System Operations (Drone Aircraft) (at 10:00 a.m. or as soon thereafter as practicable)**

Sheriff Jeff Nelson stated that Minnesota Statute 626.19 requires the County Board provide an opportunity for public comment prior to the Sheriff's office purchase or use of an unmanned aerial system (drone). No board action is required. Frandsen's Bank has donated a drone and drone accessories to the county. Sheriff Nelson addressed the purpose and use of the drone, program coordinator and pilots, prohibited uses, retention/ dissemination of data, and drafting of the departmental drone use policy.

Commissioner Ludwig inquired as to uses and citizen privacy--with/without the necessity of a warrant, discretion of viewing of data, elevation that the drone is able to fly, surveillance usage, and pilots/training to operate the drone.

Chair Hallan opened the public hearing at 10:24 a.m. and called for public comment. Mark Nisley addressed concerns related to use and citizen privacy, and the public's ability to review the written policy drafted by the sheriff's office for drone usage. Ailene Croup addressed concerns regarding costs of operation and maintenance, written policies, uses without a warrant, and audio/visual capabilities of the drone. There being no further public comment, Chair Hallan closed the meeting at 10:44 a.m.

2. **Public Hearing – Pine County Public Works Americans with Disabilities Act (ADA) Transition Plan (at 10:00 a.m. or as soon thereafter as practicable)**

Public Works Director/County Engineer Mark LeBrun explained that to receive federal transportation funds, Pine County is required, under Title II of the Americans with Disabilities Act, to perform a self-evaluation of its transportation infrastructure policies, practices and programs and pedestrian circulation/access routes including sidewalks, curb ramps, bicycle/pedestrian trails, etc. located within the county rights of way.

Chair Hallan opened the public hearing at 10:50 a.m. and called for public comment. There being no public comment, the public hearing was closed at 10:51 a.m.

Commissioner Hallan commented on the visually impaired plates at the bottom of ramps at intersections. Public Works Director LeBrun stated that most county buildings are fully compliant, however there are a few items at the highway department building to be addressed.

Motion by Commissioner Ludwig to adopt the Americans with Disabilities Act (ADA) Transition Plan. Second by Commissioner Mohr. A Roll Call vote was called by Chair Hallan: District 4-Commissioner Mikrot/Aye; District 5-Commissioner Ludwig/Aye; District 1-Chair Hallan/Aye; District 2-Commissioner Mohr/Aye; District 3-Commissioner Chaffee/Aye. Motion carried 5-0.

3. **Retirement Recognition**

The county board recognized the retirement of Deputy Auditor Terry Lovgren and thanked her for her 34+ years of service to Pine County.

4. **Personnel Committee Report**

Commissioner Ludwig provided an overview of the December 8, 2020 Personnel Committee meeting. The Personnel Committee made the following recommendations:

A. Sheriff's Office – Administrative Support

- i. Approve the promotion of part-time Sheriff's secretary Jamey Silva to full-time status, effective January 1, 2021, grade 4, minimum starting wage of \$17.66/hour.

B. Sheriff's Office - Corrections

- i. Acknowledge the resignation of Corrections Officer, Grant Crider, effective December 8, 2020 and approve backfill of the position and any subsequent vacancies due to internal promotion or lateral transfer. The position is a Grade 7 with a minimum starting wage of \$20.74/hour.
- ii. Approve the promotion of a Corrections Officer to Team Lead Sergeant prior to Sergeant Gray's February 25, 2021 retirement. This action will allow time for training, facilitate a smooth personnel transition and maintain jail safety. The promotion would be from Correction Officer Grade 7 \$20.74/hour to Sergeant Grade 10 \$24.70/hour.

C. Administration

- i. Approve policy changes and submit the following required documentation to the Minnesota Department of Human Services for the process of moving forward in withdrawing from the Minnesota Merit System on January 1, 2022:
 - Update Section 3.4 – Recruitment and Selection Process- Declaration of Policy of Equal Employment Opportunity to add language regarding the filing of complaints
 - Add Section 3.19 to establish Personnel Board of Appeals
 - Update Section 16.7 – Equal Opportunity, Non-Discrimination & Respectful Workplace to include Affirmative Action/Equal Opportunity complaint/grievance process.
 - Add Section 36 – Employee Training and Development.
 - Add Section 37 – Political Activity (Hatch Act)
 - County Board Resolution 2020-86 - Adoption of County Personnel Act
 - Certification Review Survey

Motion by Commissioner Ludwig to approve the recommendations of the Personnel Committee. Second by Commissioner Chaffee. A Roll Call vote was called by Chair Hallan: District 5-Commissioner Ludwig/Aye; District 1-Chair Hallan/Aye; District 2-Commissioner Mohr/Aye; District 3-Commissioner Chaffee/Aye; District 4-Commissioner Mikrot/Aye. Motion carried 5-0.

5. 2021 Pine County Property Tax Levy and Budget

The county board has held several budget committee meetings to review and discuss the proposed 2021 budget. All funds are balanced with budget year revenue and planned spending of reserves. The total property tax levy is \$19,935,014.

Motion by Commissioner Ludwig to approve Resolution 2020-82 Establishing the 2021 Pine County Property Tax Levy at \$19,935,014 and authorize Board Chair and County Administrator to sign. Second by Commissioner Chaffee. A Roll Call vote was called by Chair Hallan: District 1-Chair Hallan/Aye; District 2-Commissioner Mohr/Aye; District 3-Commissioner Chaffee/Aye; District 4-Commissioner Mikrot/Aye; District 5-Commissioner Ludwig/Aye. Motion carried 5-0.

Motion by Commissioner Mohr to approve Resolution 2020-83 Adopting the 2021 Pine County Budget with revenues of \$46,644,415 and expenditures of \$46,759,968 and authorize Board Chair and County Administrator to sign. Second by Commissioner Mikrot. A Roll Call vote was called by Chair Hallan: District 2-Commissioner Mohr/Aye; District 3-

Commissioner Chaffee/Aye; District 4-Commissioner Mikrot/Aye; District 5-Commissioner Ludwig/Aye; District 1-Chair Hallan/Aye. Motion carried 5-0.

BUDGET SUMMARY 2021

DEPT #	REVENUE DEPARTMENT	REVENUES	EXPENDITURES
5	COUNTY BOARD	0	261,628
13	COURT ADMINISTRATION	2,500	61,400
20	LAW LIBRARY	29,000	29,000
41	COUNTY AUDITOR-TREASURER	115,000	779,502
61	MIS	15,000	788,750
62	CENTRAL SERVICES	34,000	34,000
63	TRUTH IN TAXATION	8,000	13,500
72	COUNTY ADMINISTRATOR	500	551,484
74	AQUATIC INVASIVE SPECIES PRO	123,319	123,319
91	COUNTY ATTORNEY	147,276	1,171,911
92	CONTRACTED ATTNYS/CONSULT	0	30,000
93	VICTIM SERVICES	70,000	77,541
101	COUNTY RECORDER	306,650	393,896
105	COUNTY ASSESSOR	173,900	656,789
107	PLANNING AND ZONING	189,323	283,133
111	GOVT BUILDING OPERATIONS	192,940	810,076
121	VETERANS SERVICES	14,000	172,670
201	COUNTY SHERIFF	1,268,008	4,779,585
204	SHERIFF DISPATCH	0	837,450
205	BOAT & WATER	7,094	7,094
206	SNOWMOBILE GRANT	4,766	4,766
208	ATV GRANT	8,075	8,075
210	GUN PERMITS	45,283	45,283
212	CANINE UNIT	10,000	10,000
214	BENJAMIN NEEL GUN RANGE	2,000	2,000
227	ENHANCE 911	106,641	106,641
249	MEDICAL EXAMINER	0	62,000
251	COUNTY JAIL	276,000	4,392,312
253	COURT SECURITY	0	187,031
255	PROBATION	288,256	997,236
256	SENTENCE TO SERVE	0	87,641
281	CIVIL DEFENSE	21,615	109,538
392	SCORE RECYCLING	385,034	447,029
501	ECR LIBRARY	0	339,955
502	HISTORICAL SOCIETY	0	25,000
601	SOIL /WATER CONSERVATION	19,049	78,388
603	COUNTY EXTENTION	0	160,485
604	AGRICULTURE SOCIETY	0	10,000
605	ECONOMIC DEVELOPMENT	1,700	0
613	WATERSHED BOARD	0	9,968
702	PINE COUNTY HOUSING AUTHOR	0	4,500

801 NON-DEPARTMENTAL	15,201,558	323,800
813 MEED-CENTRAL MN INITIATIVE	0	7,450
TOTAL	19,066,487	19,281,826

DEPT HEALTH AND HUMAN SERVICES REVENUES EXPENDITURES

#		
12-420 INCOME MAINTENANCE	3,241,306	3,312,625
12-430 SOCIAL SERVICES	7,043,438	7,038,869
12-440 CHILDRENS COLLABORATIVE	134,700	134,700
12-481 NURSING	1,378,495	1,395,609
TOTAL	11,797,939	11,881,803

DEPT HIGHWAY REVENUES EXPENDITURES

#	DEPARTMENT		
13-310 ADMINISTRATION		0	380,688
13-320 ENGR/CONSTRUCTION		0	6,977,428
13-330 EQUIPMENT		0	2,173,528
13-340 REPAIR AND SHOP		0	1,928,275
13-801 NON-DEPARTMENTAL		12,125,287	665,368
TOTAL		12,125,287	12,125,287

DEPT RESOURCE DEVELOPMENT REVENUES EXPENDITURES

#	DEPARTMENT		
22-703 LAND USE		852,800	852,800
22-705 ROAD FUND GAS TAX		16,306	16,306
22-707 TIMBER DEVELOPMENT		28,422	28,422
22-708 BLIGHT CLEANUP		28,422	28,422
22-709 PARKS DEVELOP/ACQUISITION		56,844	56,844
TOTAL		982,794	982,794

DEPT BUILDING FUND REVENUES EXPENDITURES

#	DEPARTMENT		
38-801 BUILDING FUND		25,000	25,000

DEPT 2015 JAIL BONDS REVENUES EXPENDITURES

#	DEPARTMENT		
39-810 2015A JAIL BONDS		1,175,495	1,107,810

DEPT 2012A/2020A CTHSE BONDS REVENUES EXPENDITURES

#	DEPARTMENT		
40-810 2012A COURTHOUSE BONDS		1,022,548	992,071

DEPT 2017A G.O. CIP BONDS REVENUES EXPENDITURES

#	DEPARTMENT		
41-810 2017A G.O. CIP BONDS		344,831	321,577

DEPT EQUIPMENT	REVENUES EXPENDITURES	
# DEPARTMENT		
43-801 EQUIPMENT	25,000	25,000
DEPT ELECTIONS	REVENUES EXPENDITURES	
# DEPARTMENT		
44-801 ELECTIONS	79,034	16,800
TOTAL ALL FUNDS	<u>46,644,415</u>	<u>46,759,968</u>

6. **Establish 2021 Rates for Various Items**

Discussion was held regarding commissioner salary; the last commissioner compensation increase received by the board was three percent in 2016. There is no change in compensation for 2021.

A. **Establish County Commissioner Compensation/Per Diems/Mileage Reimbursement**

Motion by Commissioner Ludwig to approve Resolution 2020-85 Establishing County Commissioner Compensation as \$21,844 per year for Commissioners and \$23,044 for Board Chair (unchanged from 2020), Per Diem rate of \$100, and Mileage Reimbursement at the IRS rate for business mileage for 2021 and authorize Board Chair and County Administrator to sign. Second by Commissioner Chaffee. A Roll Call vote was called by Chair Hallan: District 3-Commissioner Chaffee/Aye; District 4-Commissioner Mikrot/Aye; District 5-Commissioner Ludwig/Aye; District 1-Chair Hallan/Aye; District 2-Commissioner Mohr/Aye. Motion carried 5-0.

B. **Elected Department Head Salaries for 2021**

County Sheriff Jeff Nelson, \$117,938 and County Attorney Reese Frederickson, \$130,987.17 effective January 1, 2021.

C. **2021 Cost-of-Living Adjustment for Non-Union Non-Elected Employees**

1.45% for January 1, 2021 and 1.25% for July 1, 2021

D. **Health Insurance County Contribution for Non-Union Employees and Elected Officials**

County contribution towards health insurance premiums for non-union employees and elected officials.

Motion by Commissioner Chaffee to approve (B) the salary of Sheriff Jeff Nelson at \$117,938 and County Attorney Reese Frederickson \$130,987.17; (C) the 2021 Cost-of-Living Adjustment for non-union employees at 1.45% for January 1, 2021 and 1.25% for July 1, 2021; and (D) 2021 health insurance contributions, HSA and VEBA contributions for full-time non-union employees and elected officials as follows:

Pine County 2021Health Insurance	Enrollment	County Premium Contribution	Annual HSA/VEBA Contribution
\$1500-80% CMM	Single	\$ 814.75	\$0
\$1500-80% CMM	Family	\$ 1,711.10	\$0
\$2150-100% VEBA	Single	\$ 764.50	\$1,275
\$2150-100% VEBA	Family	\$ 1,498.60	\$2,550
\$3000-100% HSA	Single	\$ 774.50	\$1,155
\$3000-100% HSA	Family	\$ 1,711.10	\$0

Second by Commissioner Mikrot. A Roll Call vote was called by Chair Hallan: District 4-Commissioner Mikrot/Aye; District 5-Commissioner Ludwig/Aye; District 1-Chair Hallan/Aye; District 2-Commissioner Mohr/Aye; District 3-Commissioner Chaffee/Aye. Motion carried 5-0.

7. **Establish 2021 Citizen Board and Committee Per Diems**

Resolution 2020-87 establishes the 2021 per diem rates for residents who serve on various boards and committees for the county. (This resolution does not apply to county commissioners). The per diem rates are set annually.

Motion by Commissioner Mohr to approve Resolution 2020-87 establishing per diems of \$75 for various citizen board and committees for 2021 (unchanged from 2020). Second by Commissioner Mikrot. A Roll Call vote was called by Chair Hallan: District 5-Commissioner Ludwig/Aye; District 1-Chair Hallan/Aye; District 2-Commissioner Mohr/Aye; District 3-Commissioner Chaffee/Aye; District 4-Commissioner Mikrot/Aye. Motion carried 5-0.

8. **Labor Negotiations Update**

County Administrator David Minke stated the Collective Bargaining Agreements with AFSCME represented Road and Bridge, Unit 1, Public Works Department (Highway Techs) and Road and Bridge Maintenance, Unit 2, Public Works Department (Highway Maintenance); the Pine County Road and Bridge Supervisory Unit; and the Pine County Attorney's Confidential Employees (Legal Assistants) have been approved by the bargaining units.

Motion by Commissioner Mohr to approve the 2021-2023 Collective Bargaining Agreements with Road and Bridge, Unit 1, Public Works Department (Highway Techs) and Road and Bridge Maintenance, Unit 2, Public Works Department (Highway Maintenance), both represented by AFSCME; 2021-2023 Pine County Road and Bridge Supervisory Unit; and 2021-2023 Pine County Attorney's Confidential Employees (Legal Assistants). Second by Commissioner Chaffee. A Roll Call vote was called by Chair Hallan: District 1-Chair Hallan/Aye; District 2-Commissioner Mohr/Aye; District 3-Commissioner Chaffee/Aye; District 4-Commissioner Mikrot/Aye; District 5-Commissioner Ludwig/Aye. Motion carried 5-0.

9. **Purchasing from Mohr Parts and Supplies Inc.**

Chair Mohr is the owner of Mohr Parts and Supplies Inc. in Pine City. Minnesota statute prohibits a county commissioner from having a direct or indirect interest in business with the county unless the County Board, by unanimous vote, allows the business transactions and the transactions do not require a bid under statute. The county commissioners have indicated a desire to consider this resolution on an annual basis.

Motion by Commissioner Ludwig to approve Resolution 2020-84 approving purchasing from Mohr Parts and Supplies Inc. for 2021. Second by Commissioner Mikrot. A Roll Call vote was called by Chair Hallan: District 2-Commissioner Mohr/abstained from voting; District 3-Commissioner Chaffee/Aye; District 4-Commissioner Mikrot/Aye; District 5-Commissioner Ludwig/Aye; District 1-Chair Hallan/Aye. Motion carried 4-0 with Commissioner Mohr abstaining.

10. **January 5, 2021 Organizational Meeting**

The 2021 Regular and Organizational Meeting of the Pine County Board of Commissioners will be held January 5, 2021 at 10:00 a.m. in the Board Room, Pine County Courthouse, Pine City, Minnesota. Due to the pandemic, this meeting will be in person and via WebEx and streamed live on the internet. Not more than two county commissioners will be present in the meeting room. If joining the meeting in person, the total number of persons (including commissioners) cannot exceed 10 and social distancing of at least 6 feet will be in effect.

11. **County Board Strategic Planning Session**

The Special Meeting/Committee of the Whole meeting will be held January 12, 2021 at 10:30 a.m. at the North Pine Government Center, 1602 Hwy. 23 No., Sandstone. Due to the pandemic, this meeting will be in person and via WebEx and streamed live on the internet. Not more than

two county commissioners will be present in the meeting room. If joining the meeting in person, the total number of persons (including commissioners) cannot exceed 10 and social distancing of at least 6 feet will be in effect.

12. **Coronavirus Response Update**

Community Health Services Administrator Sam Lo provided an update on the vaccine distribution related to the current public health COVID-19 situation.

13. **Commissioner Updates**

Soil & Water Conservation District (SWCD): County Administrator Minke attended this meeting, stating that SWCD has been recruiting for a district manager, but have been unable to select a candidate for this position. District Forester Paul Swanson has been appointed interim district manager for six months.

State Community Health Services Advisory Committee: Commissioner Chaffee was unable to attend this meeting. Community Health Services Administrator Sam Lo stated the main topic of discussion was related to the COVID vaccine.

Law Library: Commissioner Mohr stated the budget, usage of the library, and missing inventory was discussed.

Central MN Jobs and Training Service: Chair Hallan stated a good audit was received.

East Central Solid Waste Commission: Chair Hallan stated the intake of garbage is returning to normal.

East Central Regional Library: Commissioner Mohr was unable to attend.

Pine County Chemical Health Coalition: Commissioner Ludwig stated items discussed included Ripple Effect Mapping, Opioid Grant, T21 Compliance Checks, and the new billboard.

Other: Pine County will receive pandemic relief funds in the amount of \$568,000 and pass through to local business and non-profits to help sustain them through the pandemic.

Other: Commissioner Mikrot stated the Willow River dam project has started; most of the old dam has been removed.

14. **Other**

Chair Hallan and Commissioners Mohr and Ludwig acknowledged outgoing commissioners Chaffee and Mikrot and thanked them for their service as county commissioners.

On behalf of the commissioners, Vice-Chair Mohr thanked Chair Hallan for his service as Chair of the Pine County Board of Commissioners for 2020.

15. **Upcoming Meetings**

Upcoming meetings were reviewed.

16. **Adjourn**

With no further business, Chair Hallan adjourned the meeting at 11:51 a.m. The next regular/organizational meeting of the county board is scheduled for Tuesday, January 5, 2021 at 10:00 a.m., Board Room, Pine County Courthouse, Pine City, Minnesota.

Chair
Board of Commissioners

David J. Minke, Administrator
Clerk to County Board of Commissioners

**SUMMARY
OF
MINUTES
OF THE
PINE COUNTY BOARD MEETING
Regular Meeting
Tuesday, December 15, 2020 - 10:00 a.m.
North Pine Government Center, Sandstone, Minnesota**

Chair Steve Hallan called the meeting to order at 10:00 a.m.

Chair Hallan stated the Governor of the State of Minnesota has issued Executive Order 20-01 Declaring a Peacetime Emergency and Coordinating Minnesota's Strategy to Protect Minnesotans from COVID-19. On March 24, 2020, the Pine County Board of Commissioners declared a local emergency for Pine County.

Based on these conditions, the Chair of the Pine County Board of Commissioners has determined that the requirements of Minnesota Statute 13D.021, Subd. (1) have been met and it is not practical or prudent for all members of the county board to meet in person. Members of the county board will join the meeting remotely.

The public was invited to join the meeting remotely by phone, WebEx or watch via live stream on YouTube.

Commissioner John Mikrot and Commissioner Matt Ludwig were present in the meeting room. Members present via electronic means were Chair Hallan, Commissioner Josh Mohr and Commissioner Steve Chaffee. Also present in the meeting room was County Administrator David Minke and present via electronic means was County Attorney Reese Frederickson.

The Pledge of Allegiance was said.

Chair Hallan called for public comment. There was no public comment.

Motion by Commissioner Ludwig to adopt the amended Agenda. Second by Commissioner Mikrot. A Roll Call vote was called by Chair Hallan. Motion carried 5-0.

Motion by Commissioner Mohr to approve the Minutes of the December 1, 2020 county board meeting and Summary for publication, and the December 3, 2020 Truth in Taxation Minutes. Second by Commissioner Chaffee. A Roll Call vote was called by Chair Hallan. Motion carried 5-0.

Minutes of Boards, Reports and Correspondence

City of Sandstone Wellhead Protection Plan, Part Two

Pine County Housing and Redevelopment Authority Board of Directors Regular Meeting –
October 28, 2020

Pine County Land Surveyor Monthly Report – November 2020

Motion by Commissioner Mikrot to acknowledge the Minutes of Boards, Reports and Correspondence. Second by Commissioner Mohr. A Roll Call vote was called by Chair Hallan. Motion carried 5-0.

Motion by Commissioner Ludwig to approve the amended Consent Agenda. Second by Commissioner Mikrot. A Roll Call vote was called by Chair Hallan. Motion carried 5-0.

November, 2020 Cash Balance

Fund	November 30, 2019	November 30, 2020	Increase/Decrease
General Fund	6,366,268	7,301,820	935,552
Health and Human Services Fund	1,890,981	2,652,111	761,130
Road and Bridge Fund	3,593,725	2,255,127	(1,338,598)
CARES Act	0	750,997	750,997
Land Management Fund	2,127,760	2,331,066	203,307
TOTAL (inc non-major funds)	16,445,846	18,219,099	1,773,253

Approve the November 2020 disbursements and claims over \$2,000.

Approve the following licenses 2021 Waste Hauler Licenses and authorize Board Chair to sign: Cloquet Sanitary Service; Hartl Enterprises, LLC DBA Ron’s Rolloffs; Jim’s Mille Lacs Disposal, Inc; Jones Construction Services; LePage & Sons Inc; Pine Habitation and Supported Employment, Inc (PHASE); Mike’s Sanitation Inc; Nordstrom’s Sanitation, LLC; Waste Management.

Accept an anonymous \$750 donation to be designated as follows: \$250/Shop with a Cop program; \$250/Benjamin Neel Gun Range; \$250/K-9 program.

Approve the 2020 budget adjustments and recognition of spending of reserves.

Approve an amendment to the Violent Crime Enforcement Teams 2020 Grant. This grant has been amended to allow for funding of \$150,000 through December 31, 2021.

Approve Resolution 2020-80 extending a septic fix up special assessment to Jeannette P. Carmichael, \$20,250 and Robert Stauffer, \$17,450.

Approve the following contracts/agreements:

- A. Pine County Health & Human Services and Jennifer N. White
Clinical supervision services to adult mental health case managers. The rate is \$125 per hour, which is an increase of \$5/hour. The annual maximum cost for this service is \$6,000. One year contract (January 1, 2021 – December 31, 2021)
- B. Pine County Health & Human Services and Therapeutic Services Agency (TSA) 2021 Lead County Agreement
TSA licenses therapeutic foster homes in the region; Pine County HHS historically serves as the county agency charged with negotiating a lead county agreement as TSA works with multiple agencies but its central office is in Pine City. Most rates have remained unchanged from 2020. One year contract (January 1, 2021 – December 31, 2021)
- C. Pine County Health & Human Services and Lighthouse Child and Family Services
This contract provides for community support program services to eligible adults, and provides client outreach, medication monitoring, assistance in developing independent

living skills, crisis assistance, housing support, social support, etc. Services not to exceed \$78,000 annually, which is the same amount as 2020. One year contract (January 1, 2021 - December 31, 2021)

Approve Resolution 2020-81 declaring East Central Public School, Finlayson Elementary School, Hinckley-Finlayson High School, and Pine City High School as designated polling places for independent school district elections held in 2021.

Acknowledge list of 2020 assessment clerical corrections.

Approve the hiring of the following:

- A. Part-time dispatchers Jasmine Ploub and Marcus Hamilton-Gustafson, effective January 14, 2021, \$21.34 per hour, Grade 7, Step 1.
- B. Part-time recycling center attendant James Laposky, effective December 16, 2020, \$14.62 per hour, non-union, Grade 1.
- C. Jacqueline Ness, Clerk III, effective January 11, 2021, \$17.66 per hour, Grade 4.

Public Hearing – Unmanned Aerial System Operations (Drone Aircraft) (at 10:00 a.m. or as soon thereafter as practicable)

Sheriff Jeff Nelson stated that Minnesota Statute 626.19 requires the County Board provide an opportunity for public comment prior to the Sheriff's office purchase or use of an unmanned aerial system (drone). No board action is required. Frandsen's Bank has donated a drone and drone accessories to the county. Sheriff Nelson addressed the purpose and use of the drone, program coordinator and pilots, prohibited uses, retention/ dissemination of data, and drafting of the departmental drone use policy.

Commissioner Ludwig inquired as to uses and citizen privacy--with/without the necessity of a warrant, discretion of viewing of data, elevation that the drone is able to fly, surveillance usage, and pilots/training to operate the drone.

Chair Hallan opened the public hearing at 10:24 a.m. and called for public comment. Mark Nisley addressed concerns related to use and citizen privacy, and the public's ability to review the written policy drafted by the sheriff's office for drone usage. Ailene Croup addressed concerns regarding costs of operation and maintenance, written policies, uses without a warrant, and audio/visual capabilities of the drone. There being no further public comment, Chair Hallan closed the meeting at 10:44 a.m.

Public Hearing – Pine County Public Works Americans with Disabilities Act (ADA) Transition Plan (at 10:00 a.m. or as soon thereafter as practicable)

Public Works Director/County Engineer Mark LeBrun explained that to receive federal transportation funds, Pine County is required, under Title II of the Americans with Disabilities Act, to perform a self-evaluation of its transportation infrastructure policies, practices and programs and pedestrian circulation/access routes including sidewalks, curb ramps, bicycle/pedestrian trails, etc. located within the county rights of way.

Chair Hallan opened the public hearing at 10:50 a.m. and called for public comment. There being no public comment, the public hearing was closed at 10:51 a.m.

Commissioner Hallan commented on the visually impaired plates at the bottom of ramps at intersections. Public Works Director LeBrun stated that most county buildings are fully compliant, however there are a few items at the highway department building to be addressed.

Motion by Commissioner Ludwig to adopt the Americans with Disabilities Act (ADA) Transition Plan. Second by Commissioner Mohr. A Roll Call vote was called by Chair Hallan. Motion carried 5-0.

Personnel Committee Report

Commissioner Ludwig provided an overview of the December 8, 2020 Personnel Committee meeting. The Personnel Committee made the following recommendations:

- A. Sheriff's Office – Administrative Support
 - i. Approve the promotion of part-time Sheriff's secretary Jamey Silva to full-time status, effective January 1, 2021, grade 4, minimum starting wage of \$17.66/hour.
- B. Sheriff's Office - Corrections
 - i. Acknowledge the resignation of Corrections Officer, Grant Crider, effective December 8, 2020 and approve backfill of the position and any subsequent vacancies due to internal promotion or lateral transfer. The position is a Grade 7 with a minimum starting wage of \$20.74/hour.
 - ii. Approve the promotion of a Corrections Officer to Team Lead Sergeant prior to Sergeant Gray's February 25, 2021 retirement. This action will allow time for training, facilitate a smooth personnel transition and maintain jail safety. The promotion would be from Correction Officer Grade 7 \$20.74/hour to Sergeant Grade 10 \$24.70/hour.
- C. Administration
 - i. Approve policy changes and submit the following required documentation to the Minnesota Department of Human Services for the process of moving forward in withdrawing from the Minnesota Merit System on January 1, 2022:
 - Update Section 3.4 – Recruitment and Selection Process- Declaration of Policy of Equal Employment Opportunity to add language regarding the filing of complaints
 - Add Section 3.19 to establish Personnel Board of Appeals
 - Update Section 16.7 – Equal Opportunity, Non-Discrimination & Respectful Workplace to include Affirmative Action/Equal Opportunity complaint/grievance process.
 - Add Section 36 – Employee Training and Development.
 - Add Section 37 – Political Activity (Hatch Act)
 - County Board Resolution 2020-86 - Adoption of County Personnel Act
 - Certification Review Survey

Motion by Commissioner Ludwig to approve the recommendations of the Personnel Committee. Second by Commissioner Chaffee. A Roll Call vote was called by Chair Hallan. Motion carried 5-0.

Motion by Commissioner Ludwig to approve Resolution 2020-82 Establishing the 2021 Pine County Property Tax Levy at \$19,935,014. Second by Commissioner Chaffee. A Roll Call vote was called by Chair Hallan. Motion carried 5-0.

Motion by Commissioner Mohr to approve Resolution 2020-83 Adopting the 2021 Pine County Budget with revenues of \$46,644,415 and expenditures of \$46,759,968. Second by Commissioner Mikrot. A Roll Call vote was called by Chair Hallan. Motion carried 5-0.

BUDGET SUMMARY 2021

DEPT #	REVENUE DEPARTMENT	REVENUES	EXPENDITURES
5	COUNTY BOARD	0	261,628
13	COURT ADMINISTRATION	2,500	61,400
20	LAW LIBRARY	29,000	29,000
41	COUNTY AUDITOR-TREASURER	115,000	779,502
61	MIS	15,000	788,750
62	CENTRAL SERVICES	34,000	34,000
63	TRUTH IN TAXATION	8,000	13,500
72	COUNTY ADMINISTRATOR	500	551,484
74	AQUATIC INVASIVE SPECIES PRO	123,319	123,319
91	COUNTY ATTORNEY	147,276	1,171,911
92	CONTRACTED ATTNYS/CONSULT	0	30,000
93	VICTIM SERVICES	70,000	77,541
101	COUNTY RECORDER	306,650	393,896
105	COUNTY ASSESSOR	173,900	656,789
107	PLANNING AND ZONING	189,323	283,133
111	GOVT BUILDING OPERATIONS	192,940	810,076
121	VETERANS SERVICES	14,000	172,670
201	COUNTY SHERIFF	1,268,008	4,779,585
204	SHERIFF DISPATCH	0	837,450
205	BOAT & WATER	7,094	7,094
206	SNOWMOBILE GRANT	4,766	4,766
208	ATV GRANT	8,075	8,075
210	GUN PERMITS	45,283	45,283
212	CANINE UNIT	10,000	10,000
214	BENJAMIN NEEL GUN RANGE	2,000	2,000
227	ENHANCE 911	106,641	106,641
249	MEDICAL EXAMINER	0	62,000
251	COUNTY JAIL	276,000	4,392,312
253	COURT SECURITY	0	187,031
255	PROBATION	288,256	997,236
256	SENTENCE TO SERVE	0	87,641
281	CIVIL DEFENSE	21,615	109,538
392	SCORE RECYCLING	385,034	447,029
501	ECR LIBRARY	0	339,955
502	HISTORICAL SOCIETY	0	25,000
601	SOIL /WATER CONSERVATION	19,049	78,388
603	COUNTY EXTENTION	0	160,485
604	AGRICULTURE SOCIETY	0	10,000
605	ECONOMIC DEVELOPMENT	1,700	0
613	WATERSHED BOARD	0	9,968
702	PINE COUNTY HOUSING AUTHOR	0	4,500
801	NON-DEPARTMENTAL	15,201,558	323,800
813	MEED-CENTRAL MN INITIATIVE	0	7,450
TOTAL		19,066,487	19,281,826

DEPT HEALTH AND HUMAN SERVICES REVENUES	EXPENDITURES	
#		
12-420 INCOME MAINTENANCE	3,241,306	3,312,625
12-430 SOCIAL SERVICES	7,043,438	7,038,869
12-440 CHILDRENS COLLABORATIVE	134,700	134,700
12-481 NURSING	1,378,495	1,395,609
TOTAL	11,797,939	11,881,803

DEPT HIGHWAY	REVENUES	EXPENDITURES
# DEPARTMENT		
13-310 ADMINISTRATION	0	380,688
13-320 ENGR/CONSTRUCTION	0	6,977,428
13-330 EQUIPMENT	0	2,173,528
13-340 REPAIR AND SHOP	0	1,928,275
13-801 NON-DEPARTMENTAL	12,125,287	665,368
TOTAL	12,125,287	12,125,287

DEPT RESOURCE DEVELOPMENT	REVENUES	EXPENDITURES
# DEPARTMENT		
22-703 LAND USE	852,800	852,800
22-705 ROAD FUND GAS TAX	16,306	16,306
22-707 TIMBER DEVELOPMENT	28,422	28,422
22-708 BLIGHT CLEANUP	28,422	28,422
22-709 PARKS DEVELOP/ACQUISITION	56,844	56,844
TOTAL	982,794	982,794

DEPT BUILDING FUND	REVENUES	EXPENDITURES
# DEPARTMENT		
38-801 BUILDING FUND	25,000	25,000

DEPT 2015 JAIL BONDS	REVENUES	EXPENDITURES
# DEPARTMENT		
39-810 2015A JAIL BONDS	1,175,495	1,107,810

DEPT 2012A/2020A CTHSE BONDS	REVENUES	EXPENDITURES
# DEPARTMENT		
40-810 2012A COURTHOUSE BONDS	1,022,548	992,071

DEPT 2017A G.O. CIP BONDS	REVENUES	EXPENDITURES
# DEPARTMENT		
41-810 2017A G.O. CIP BONDS	344,831	321,577

DEPT EQUIPMENT
DEPARTMENT
43-801 EQUIPMENT

REVENUES EXPENDITURES
25,000 25,000

DEPT ELECTIONS
DEPARTMENT
44-801 ELECTIONS

REVENUES EXPENDITURES
79,034 16,800

TOTAL ALL FUNDS

46,644,415 46,759,968

Establish 2021 Rates for Various Items

A. Establish County Commissioner Compensation/Per Diems/Mileage Reimbursement
Motion by Commissioner Ludwig to approve Resolution 2020-85 Establishing County Commissioner Compensation as \$21,844 per year for Commissioners and \$23,044 for Board Chair (unchanged from 2020), Per Diem rate of \$100, and Mileage Reimbursement at the IRS rate for business mileage for 2021. Second by Commissioner Chaffee. A Roll Call vote was called by Chair Hallan. Motion carried 5-0.

B. Elected Department Head Salaries for 2021
 County Sheriff Jeff Nelson, \$117,938 and County Attorney Reese Frederickson, \$130,987.17 effective January 1, 2021.

C. 2021 Cost-of-Living Adjustment for Non-Union Non-Elected Employees
 1.45% for January 1, 2021 and 1.25% for July 1, 2021

D. Health Insurance County Contribution for Non-Union Employees and Elected Officials
 County contribution towards health insurance premiums for non-union employees and elected officials.

Motion by Commissioner Chaffee to approve (B) the salary of Sheriff Jeff Nelson at \$117,938 and County Attorney Reese Frederickson \$130,987.17; (C) the 2021 Cost-of-Living Adjustment for non-union employees at 1.45% for January 1, 2021 and 1.25% for July 1, 2021; and (D) 2021 health insurance contributions, HSA and VEBA contributions for full-time non-union employees and elected officials as follows:

Pine County 2021 Health Insurance	Enrollment	County Premium Contribution	Annual HSA/VEBA Contribution
\$1500-80% CMM	Single	\$ 814.75	\$0
\$1500-80% CMM	Family	\$ 1,711.10	\$0
\$2150-100% VEBA	Single	\$ 764.50	\$1,275
\$2150-100% VEBA	Family	\$ 1,498.60	\$2,550
\$3000-100% HSA	Single	\$ 774.50	\$1,155
\$3000-100% HSA	Family	\$ 1,711.10	\$0

Second by Commissioner Mikrot. A Roll Call vote was called by Chair Hallan. Motion carried 5-0.

Motion by Commissioner Mohr to approve Resolution 2020-87 establishing per diems of \$75 for various citizen board and committees for 2021 (unchanged from 2020). Second by Commissioner Mikrot. A Roll Call vote was called by Chair Hallan. Motion carried 5-0.

Motion by Commissioner Mohr to approve the 2021-2023 Collective Bargaining Agreements with Road and Bridge, Unit 1, Public Works Department (Highway Techs) and Road and Bridge Maintenance, Unit 2, Public Works Department (Highway Maintenance), both represented by

AFSCME; 2021-2023 Pine County Road and Bridge Supervisory Unit; and 2021-2023 Pine County Attorney's Confidential Employees (Legal Assistants). Second by Commissioner Chaffee. A Roll Call vote was called by Chair Hallan. Motion carried 5-0.

Motion by Commissioner Luwig to approve Resolution 2020-84 approving purchasing from Mohr Parts and Supplies Inc. for 2021. Second by Commissioner Mikrot. A Roll Call vote was called by Chair Hallan. Motion carried 4-0 with Commissioner Mohr abstaining.

The 2021 Regular and Organizational Meeting of the Pine County Board of Commissioners will be held January 5, 2021 at 10:00 a.m. in the Board Room, Pine County Courthouse, Pine City, Minnesota.

The Special Meeting/Committee of the Whole meeting will be held January 12, 2021 at 10:30 a.m. at the North Pine Government Center, 1602 Hwy. 23 No., Sandstone.

With no further business, Chair Hallan adjourned the meeting at 11:51 a.m. The next regular/organizational meeting of the county board is scheduled for Tuesday, January 5, 2021 at 10:00 a.m., Board Room, Pine County Courthouse, Pine City, Minnesota.

Chair
Board of Commissioners

David J. Minke, Administrator
Clerk to County Board of Commissioners

The full text of the board's Minutes are available at the County Administrator's Office and the county's website (www.co.pine.mn.us). Copies may also be requested from the administrator's office.

Pine County Chemical Health Coalition Minutes
December 14, 2020
Online

Coalition Mission Statement

Pine County Chemical Health Coalition: Striving to prevent the misuse and abuse of alcohol, tobacco and other drugs

Attendance:

Reese Frederickson, *Pine Co Attorney*
Nick Stilp, *The Improve Group*
Kjersten Anderson, *Metro Area Regional Prevention Coordinator*
Brian Miner, *East Central Regional Prevention Coordinator*
Paul Widenstrom, *Pine Co Sheriff's Dept*
Kevin Glass, *Pine Co Probation*
Jamie Root-Larsen, *Positive Community Norms Media Specialist*
Matt Ludwig and John Mikrot Jr, *Pine County Commissioners*
Becky Foss, Hailey Freedlund, Jenae Hicks, Karen Jansen, Samantha Lo, *Pine Co Health & Human Services*

1. Call to Order

Meeting commenced at 4:00 pm by Reese Frederickson.

2. Addition/Changes to the Agenda

Motion to approve agenda by Becky Foss, seconded by Jamie Root-Larsen. Motion carried.

3. Review Minutes of November 9, 2020

Matt Ludwig moved to 11/9/20 meeting minutes. Samantha Lo seconded the motion and minutes were accepted.

SPIRIT

1. Member Introductions and Welcome

Brian Miner and Nick Stilp introduced selves and lead member introductions.

SCIENCE

1. Brian Miner and Nick Stilp

a. Ripple Effect Mapping

- Facilitated workshop as group reflected on the effects of their initiative to reduce underage drinking and substance use in the community.
- Members interviewed each other about the effects they've seen and submitted the interviews as completed. They answered:
 - What parts of the coalition's work are you most proud of or excited about? Why?
 - How is your community different because of your coalition's work?
 - What is better or improved since your coalition started working together?
- The second workshop will be during the next coalition meeting, which will be on Zoom, January 11th at 4:00 pm. Effects collected in the first session will be reviewed and evaluated for how they fit together. A 'map' will be created.

2. Becky Foss

a. Opioid Grant with U of M

- The County Board gave a letter of support for an outpatient treatment agency in Sandstone; Ascertain Recovery Centre. The agency will do chemical use assessments and referrals for mental health services.
- Opioid training and technical assistance are done through the grant. Much was paused due to COVID. Naloxone training will be Thursday, 12/17, at 7:00 pm on Zoom. The goal is to have participants receive a kit. To sign up or ask questions: contact Anna Van Deelen at opioividista@d.umn.edu.
- Laura Palombi, U of M College of Pharmacy, is examining the role pharmacists and associates can play in the area of substance use prevention, intervention, recovery and harm reduction. If interested in an interview, email Laura at lpalombi@d.umn.edu.

3. Hailey Freedlund

a. Tobacco and Other Drugs

- Completed a flyer to send out to 10 retailers that failed T21 Compliance Checks, encouraging them to take Stop Sales to Minors training.
- Retailers will receive a Certificate of Compliance when training is completed.
- Coalition will be emailed a flyer
- In the future, this may be required training after compliance failure.

ACTION

1. Jenae Hicks

a. Upcoming Member Training

Workshop 1: Introduction to Positive Community Norms

This two-part, four-hour training will renew your spirit and bring fresh energy to your work. Join us to learn about this powerful framework for reducing harm, improving health and strengthening community cultures. We will unpack the power of the positive approach and provide you with effective communication skills that you can put to use immediately. Great for newcomers as well as those looking for an updated overview.

- TIMING: January 14th and 15th from 11:30 to 1:30 CT
- COST: \$175

Workshop 2: Practicing the Science of the Positive in Challenging Times

What does positive messaging look like during a global pandemic? Can we apply Positive Community Norms to messaging about COVID19? How can we continue messaging about anything else? This team-led series of five virtual workshops will address these questions and show how the Science of the Positive can be a touchstone for public health practitioners during difficult and confusing times. No previous experience is necessary, but we recommend that newcomers also register for the Introduction to Positive Community Norms.

- *TIMING: January 21 & 28, and February 4, 11 & 18 from 11:30 to 1:30 CT*
- *COST: \$375/person*

Workshop 3: Crafting Your Transformational Leadership Narrative

Expand your leadership capacity in this interactive, introspective, and inspirational workshop. Before the sessions begin, you'll take our innovative Science of the Positive Transformational Leadership Assessment and receive a personalized Leadership Profile based on your results. During the live workshop, you will use a creative mix of individual and group storytelling exercises to construct a personal leadership narrative that will increase your clarity, effectiveness, and confidence as a community leader and change-maker.

- *TIMING: Tuesday, March 23 from 1:00 to 4:00pm CT & Wednesday, March 24 from 11:00 to 2:00 pm CT*
- *COST: \$225/person, including assessment & all materials. Enrollment limited.*

Training will be paid by the P & I Grant. Contact Karen to register.

2. Jamie Root-Larsen

a. Media Update

- Created flyer for tobacco and alcohol compliance fails
- Designed social media snippets; 6 weeks of HF, EC, and coalition/adult community messages
- HF students will be receiving towels
- New billboards are up on I35

3. Teams – No reports

RETURN

1. News from the Schools

- Youth groups are still meeting and leaders are on track. Blankets are a huge hit.

2. Training/Volunteer/Event Reports from Members

- Jenaë's baby is due in a few days. All wished her well!
- Annual Safe and Sober program on WCMP 100.9 tonight at 5:00 pm.

3. Next Meeting – Monday, January 11th, 2020, 4:00 pm – Zoom online

4. Adjourned- 4:58 pm. *Matt Ludwig made a motion, Kevin Glass seconded, and meeting was adjourned.*

Minutes prepared by Karen Jansen. \\PCCHC\Minutes\2020\Dec 14 min.doc



PINE COUNTY PUBLIC WORKS

HIGHWAY DEPARTMENT

405 Airport Road NE
Pine City, MN 55063

Telephone 320-216-4200
Fax: 320-629-6736
1-800-450-7463 Ext. 4200

Mark A. LeBrun, P.E.
County Engineer

Pine County Land Surveyor Monthly Report

December 2020

T42N R17W Section 4, search for, set, tie out and GPS PLSS corners, Update records.

T43N R16W Section 1, research records, calculate search areas, set GPS control, search for, set, tie out and GPS PLSS corners, Update records.

Sturgeon Island Road, T45N R19W, research records, calculate search areas, search for, set, tie out and GPS PLSS corners, Update records.

Provide HARN coordinate data for GIS to County Recorder as needed.

Draft and review legal descriptions for County Right of Way Dept. and County Land Dept. as needed.

Review Plats and Minor Subdivisions for County Zoning Dept. as needed.

Review and file PLSS corner certificates provided by private surveyors as needed.

Review, edit and file PLSS corner certificates created by County Surveyor as needed.

Review, edit and file Certificates of Survey created by County Surveyor as needed.

Robin T. Mathews, Pine County Surveyor



AGENDA REQUEST FORM

Date of Meeting: January 5th, 2021

- County Board**
 Consent Agenda
 Regular Agenda 5 mins. 10 mins. 15 mins. Other
- Personnel Committee**
- Other** _____

Agenda Item: Donations to Pine County Sheriff's Office for annual Toy Drive

Department: Pine County Sheriff's Office

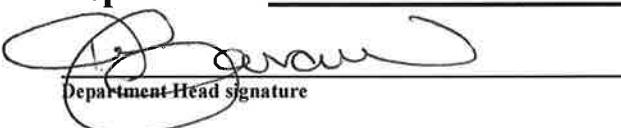
Department Head signature

Background information on Item:

The Pine County Sheriff's Office received a donation from Atscott Manufacturing for \$500 for the annual PCSO Toy Drive.

Action Requested:

The Pine County Sheriff's Office respectfully asks the County Board to acknowledge and accept the donation into the Pine County Sheriff's Office for the Pine County Sheriff's Office Toy Drive.

Financial Impact:

Donations for the the annual PCSO Toy Drive are not supplemented with any department funding.



AGENDA REQUEST FORM

Date of Meeting: January 5, 2021

- County Board**
 - Consent Agenda**
 - Regular Agenda** 5 mins. ___ 10 mins. ___ 15 mins. ___ Other ___
- Personnel Committee**
- Other** _____

Agenda Item: SWCD Administrative Support Contract

Department: Auditor/Treasurer

 Department Head signature

Background information on Item:

The Pine Soil and Water Conservation District (SWCD) experienced two recent resignations, including their District Manager position. On December 9, 2020 the SWCD appointed their District Forester, Paul Swanson, as Interim Manager. As the SWCD acclimates to a change in management and seeks to fill vacancies, they are interested in temporary clerical assistance from the County Zoning Department.

The County Zoning Department, being outside of the construction season, has ability to provide some administrative support staff time to assist the SWCD.

County Attorney Frederickson has reviewed the contract.

Action Requested:

Authorize the County Board Chair to sign a contract with Pine SWCD for administrative support.

Financial Impact:

This contract will generate revenue equivalent to the cost of the staff time and will help offset Planning and Zoning expenses.

Administrative Support Agreement

Between Pine Soil & Water Conservation District and the County of Pine, Minnesota

This Service Agreement (“Agreement”) is made and entered into this _____ day of _____, 2021 between Pine County, Minnesota, 635 Northridge Drive NW, Pine City, Minnesota (“the County”) and the Pine Soil & Water Conservation District (“SWCD”), 1610 Hwy 23 N, Sandstone, Minnesota.

In consideration of the mutual promises and agreements hereinafter set forth, the parties do hereby agree as follows:

1. **Administrative Support Services.** SWCD agrees to purchase from the County, and the County agrees to provide the following administrative support services in the type and manner described:
 - a. **Services.** The services consist of traditional clerical services such as managing records, mailings, data entry, preparing documents, assisting with program implementation, customer service/support, etc. SWCD and the County will discuss and reach agreement including the timeline, deliverables and estimated costs for services on an on-going basis. The County, its officers and employees, shall not be liable to SWCD or any other person for failure to furnish assistance under this Agreement.
 - b. **Allocation of Resources.** Administrative support services are to be delivered from the County Planning, Zoning, and Solid Waste Department. The parties understand that the County’s administrative support service needs come first. The County will endeavor to reasonably provide the desired services, but makes no guarantee to provide the requested consulting services. The provision of services under this Agreement is at the sole discretion of the County.
 - c. The Pine SWCD District Manager shall communicate all task requests to the County Land and Resources Manager. Tasks are expected to be 8-16 hours per week, but may be more or less, upon mutual agreement, as workload fluctuates.
2. **Payment.** County shall bill SWCD for work performed. SWCD agrees to pay County within thirty (30) days of receiving an invoice.

The following rates shall apply:

<u>Services work</u>	\$26 per hour (this rate shall apply to time worked by county staff and include travel time, if necessary)
-----------------------------	--

3. **Term.** This contract shall commence on the effective date indicated above and shall expire December 31, 2021 unless terminated earlier as provided herein.
4. **Ownership.** The County shall provide final documents of work product to SWCD in an electronic format. These documents may be in paper format if desired by SWCD. SWCD shall retain ownership of final documents.

5. **Indemnification.** Except as arising from or out of the County's fault or negligence, SWCD agrees to indemnify and defend the County, its officials, agents, and employees against and will hold harmless the County, its officials, agents and employees from any claims expenses or damages, including attorneys' fees arising from the SWCD's performance of its obligations pursuant to this Agreement.

Except as arising from or out of SWCD's fault or negligence, the County agrees to indemnify and defend SWCD, its officials, agents, and employees against and will hold harmless SWCD, its officials, agents and employees from any claims expenses or damages, including attorney's fees arising from the County's performance of its obligations pursuant to this Agreement.

6. **No Waiver.** Nothing herein shall be construed to waive or limit any immunity from, or limitation on, liability available to either party, whether set forth in Minnesota Statutes Chapter 466 or otherwise.
7. **Modification.** This writing contains the entire agreement between the parties and no alterations, variations, modifications, or waivers of the provisions of this Agreement are valid unless reduced to writing, signed by both SWCD and the County, and attached hereto.
8. **Subcontracting & Assignment.** The County shall not subcontract or assign any portion of this Agreement to another without prior written permission from SWCD.
9. **Termination.** This Agreement may be terminated at anytime during its term by mutual agreement of the parties. Either party may terminate this Agreement by personally serving a seven (7)-day written notice of termination on the other party. Notice to SWCD shall be served on the SWCD District Manager, and notice to the County shall be served on the Land and Resources Manager. In the event of termination, SWCD shall pay for work completed and County shall provide such work project as is completed until the time of termination and paid for by SWCD.
10. **Service Contract.** This is a service agreement. The parties do not intend to undertake or create, and nothing herein shall be construed as creating, a joint powers agreement, joint venture, or joint enterprise between the parties.
11. **Independent Contractor.** The parties understand that at all times the County is an independent contractor and not an employee of SWCD.
12. **Data Practices.** Data provided, produced or obtained under this Agreement shall be administered in accordance with the Minnesota Government Data Practices Act, Minnesota Statutes Chapter 13.

The County will immediately report to SWCD any requests from third parties for information relating to this Agreement. The County agrees to promptly respond to inquiries from SWCD concerning data requests.

SWCD will immediately report to the County any requests from third parties for information relating to this Agreement. SWCD agrees to promptly respond to inquiries from the County concerning data requests.

13. **Minnesota Law Governs.** This Agreement shall be governed by and construed in accordance with the laws of the State of Minnesota. All proceedings related to this Agreement shall be venued in any court having jurisdiction over Pine County.

14. **Severability.** The provisions of this Agreement shall be deemed severable. If any part of this Agreement is rendered void, invalid, or otherwise unenforceable, such rendering shall not affect the validity and enforceability of the remainder of this Agreement.

County:

SWCD:

By: _____

By: _____

Its: County Board Chair

Attest:

By: _____

By: _____

David J. Minke
Its: County Administrator

Approved as to Form:

By: _____

Reese Frederickson
Its: County Attorney



AGENDA REQUEST FORM

Date of Meeting: January 5, 2021

- County Board**
 - Consent Agenda**
 - Regular Agenda** 5 mins. ___ 10 mins. ___ 15 mins. ___ Other ___
- Personnel Committee**
- Other** _____

Agenda Item: Approve Contract with Rise Up Psychological Services

Department: HHS

Rebecca Foss
Department Head signature

Background information on Item:

HHS is required to provide clinical supervision to children’s mental health case managers. The attached contract with Rise Up Psychological Services meets that requirement and is at a cost of \$125/hour (three hours per month; \$4,500/year).

This contract also allows for the provision of reflective practice supervision to designated HHS employees, including public health family home visiting staff and child protection staff, at a rate of \$100/hour (maximum of \$15,600/year). Expenses from this service are paid by the Evidence Based Family Home Visiting Grant received by public health, and the Child Protection Grant received by social services.

The contract is from January 1, 2021 through December 31, 2021. It has been reviewed by the County Attorney’s Office

Action Requested:

Authorize Board Chairperson and the County Administrator to sign the contract between Pine County Health and Human Services and Rise Up Psychological Services.

Financial Impact:

These expenses are included in the 2021 HHS budget. As noted above, the required clinical supervision services cost \$4,500 per year. The reflective practice supervision services cost no more than \$15,600 per year. The reflective practice supervision services are paid for through grants received by Pine County HHS from the Minnesota Department of Health and the Minnesota Department of Human Services.

AGREEMENT BETWEEN
PINE COUNTY HEALTH & HUMAN SERVICES
AND RISE UP PSYCHOLOGICAL SERVICES FOR
CLINICAL AND REFLECTIVE PRACTICE SUPERVISION SERVICES

The County of Pine, acting through its Health & Human Services Department, 315 Main St S, Suite 200, Pine City, Minnesota, 55063, ("Agency"), and Rise Up Psychological Services LLC, 1100 Holstein Drive NE, Pine City, Minnesota, 55063, ("Contractor"), enter into this Contract effective for the period of January 1, 2021 through December 31, 2021.

WHEREAS, The Contractor is duly qualified to provide clinical supervision; and

WHEREAS, Minnesota Statutes, section 245.462 subdivision 4a defines "Clinical supervision" as "the oversight responsibility for individual treatment plans and individual mental health service delivery, including that provided by the case manager. Clinical supervision must be accomplished by full or part-time employment of or contracts with mental health professionals. Clinical supervision must be documented by the mental health professional cosigning individual treatment plans and by entries in the client's record regarding supervisory activities;"

WHEREAS, reimbursement from Minnesota Health Care Programs (MHCP) requires that the professional providing clinical supervision be licensed at the independent clinical level or tribal-credentialed mental health professional, and be enrollable in the MHCP provider system as a licensed mental health professional.

WHEREAS, Agency wishes to purchase reflective practice supervision services for public health staff and social services staff; and

WHEREAS, Agency, pursuant to Minnesota Statutes, sections 373.01, and 256M.60 wishes to purchase such program services from Contractor;

NOW THEREFORE, in consideration of the mutual understandings, and agreements set forth, Agency and Contractor agree as follows:

1. Contractor's Duties:

Agency and Contractor enter into a service agreement for the provision of monthly Clinical Supervision of Pine County Children social workers to provide clinical oversight of the delivery of mental health case management services, as required by MHCP standards and Minnesota Statutes and as arranged by the agency with Contractor. Contractor will review and determine the clinical appropriateness of the supervisee's "individual service delivery," as defined by MHCP standards, with respect to the client's identified mental health condition. Contractor also agrees to provide reflective practice supervision to designated public health staff and to designated social services employees as agreed and arranged by Agency and Contractor.

PINE COUNTY HEALTH & HUMAN SERVICES
& Rise Up Psychological Services
CLINICAL AND REFLECTIVE PRACTICE SUPERVISION SERVICES
2021

2. Cost and Delivery of Purchased Services:

Rates for services are \$125.00 per hour for a maximum of three hours per month for clinical supervision; \$100.00 per hour for up to six hours per month for reflective practice supervision for public health staff and up to seven hours per month for reflective practice supervision for designated social services employees beginning January 1, 2021 and continuing through December 31, 2021.

This is a fee-for-service Contract, which indicates that payment shall be for services provided during the Contract period, and all payments for services shall be invoiced and disbursed during that period. Monthly invoices should be sent within 30 days of service to the attention of the Director, Pine County Health and Human Services.

3. Payment for Purchased Services:

a. Certification of expenditures:

Contractor shall, within 30 days following the last day of each calendar month, submit a standard invoice for services purchased, to Pine County Health & Human Services. Bills that do not meet internal county deadlines will be paid later. The Invoice shall show an itemized account of services provided.

b. Payment:

Agency shall, within thirty (30) days of the date of receipt of the Invoice, make payment to the Contractor for all reimbursement-eligible services identified on the invoice.

4. Audit and Record Disclosure:

Contractor shall:

a. Maintain records, using generally accepted accounting principles that reflect all revenue received and all direct and indirect costs incurred in performing this Contract. Maintain records about Purchased Services provided, service dates, and other information that is required by Agency. Maintain any other records requested by Agency.

b. Upon request, Contractor agrees to give Agency a report containing the following information:

1. All revenue received.
2. All direct and indirect costs incurred in performing Purchased Services.

PINE COUNTY HEALTH & HUMAN SERVICES
& Rise Up Psychological Services
CLINICAL AND REFLECTIVE PRACTICE SUPERVISION SERVICES
2021

- c. Allow personnel of Agency, the Minnesota Department of Human Services, and the Minnesota Department of Health, access to the Contractor's facility and records at reasonable hours to exercise their responsibility to monitor purchased services and copy such materials as necessary.
- d. Maintain all records pertaining to the contract at 1100 Holstein Dr. NE, Pine City, MN, 55063. Contractor agrees to store records for three (3) years for audit purposes.
- e. Comply with policies of the Minnesota Department of Human Services regarding social services recording and monitoring procedures, as defined in the Department of Human Services Social Services Manual, and the administrative rules of the State Agency.

5. Safeguard of Client Information:

The use or disclosure by any party of information regarding an eligible client in violation of any rule of confidentiality provided for in Minnesota Statutes, Chapter 13 (the Minnesota Government Data Practices Act), or for any purpose not directly connected with Agency's or Contractor's responsibility with respect to the Purchased Services hereunder is prohibited. Per Minnesota Statutes section 13.46 subdivision 10(a)(4), Contractor is the responsible authority under the Minnesota Government Data Practices Act.

All data collected, created, received, maintained, or disseminated for any purposes during Contractor's performance of this Contract is governed by Minnesota Statutes, section 13.01 et. seq., or any other applicable State statutes, any State rules adopted to implement the Minnesota Government Data Practices Act, as well as Federal regulations on Data Privacy, including the Health Insurance Portability and Accountability Act (HIPAA). Contractor agrees to abide by these statutes, rules, and regulations.

6. Compliance with Other Regulations:

Contractor further agrees to comply with the following:

- a. Minnesota Statutes section 604.202 (Liability of Employer).
- b. Contractor agrees to comply with the Civil Rights Act of 1964, Title VII (42 USC 2000e); including Executive Order No. 11246, and Title VI (42 USC 2000d); and the Rehabilitation Act of 1973, as amended by Section 504. Title VI of the Civil Rights Act of 1964 (Title VI) requires service providers who receive federal funds to take reasonable steps to provide meaningful access to

PINE COUNTY HEALTH & HUMAN SERVICES
& Rise Up Psychological Services
CLINICAL AND REFLECTIVE PRACTICE SUPERVISION SERVICES
2021

services for people with Limited English Proficiency (LEP). Most county and state funded services must meet LEP requirements. The requirements apply to health care and social service agencies, such as physicians, hospitals, nursing homes, home health agencies, managed care organizations, universities, and private non-profit agencies.

7. Fair Hearing and Grievance Procedures:
Agency agrees to provide for a fair hearing and grievance procedure conformance with Minnesota Statutes, section 256.045, and in conjunction with the Fair Hearing and Grievance Procedures established by administrative rules of the Department of Human Services.

8. Indemnity and Insurance
 - a. Indemnity:
The Contractor agrees that it will indemnify and hold harmless Agency from any and all liability, loss, damages, costs or expenses which may be claimed against Agency or Contractor;
 - (1) By reason of any service client's suffering personal injury, death or property loss or damages either while participating in or receiving from Contractor the care and services to be furnished by Contractor under this Contract, or while on premises owned, leased or operated by the Contractor, or while being transported to or from said premises in any vehicle owned, operated, chartered or otherwise contracted for by Contractor or his/her assignees: or
 - (2) By reason of any service client's causing injury to, or damage to, the property of another person during any time when Contractor or his/her assigns, or employee thereof has undertaken or is furnishing the care and service called for under this Contract.
 - b. Insurance:
Contractor will furnish an original Certificate of Insurance as evidence of required coverage to Agency. Insurance should include professional liability coverage acceptable to Agency.

9. Conditions of the Parties' Obligations
 - a. It is understood and agreed that in the event the reimbursement to Agency from State and Federal sources is not obtained and continued at a level sufficient to allow for the purchase of the indicated quantity of Purchased Services, the obligations of

PINE COUNTY HEALTH & HUMAN SERVICES
& Rise Up Psychological Services
CLINICAL AND REFLECTIVE PRACTICE SUPERVISION SERVICES
2021

each party hereunder shall thereupon be terminated.

- b. This Contract may be canceled by either party at any time, with or without cause, upon thirty (30) days notice, in writing, delivered by mail or in person.
- c. Any alterations, variations, modifications, or waivers of provisions of this Contract shall be valid only when they have been reduced to writing, duly signed, and attached to the original of this Contract.
- d. No claim for services furnished by Contractor, not specifically provided in the Contract, will be allowed by the Agency, nor shall Contractor do any work or furnish any material not covered by the Contract, unless this is approved in writing by Agency. Such approval shall be a modification of the Contract.

10. Subcontracting:

Contractor shall not enter into subcontracts for any of the goods and services contemplated under this Contract without written approval of Agency. All subcontracts shall be subject to the requirements of this contract. Contractor shall be responsible for the performance of any subcontractor.

11. Miscellaneous:

a. Entire Agreement:

It is understood and agreed that the entire agreement of the parties is contained herein and that this Contract supersedes all oral agreements and negotiations between the parties relating to the subject matter hereof, as well as any previous agreements presently in effect between Contractor and any county social services agency relating to the subject matter hereof.

b. Monitoring:

It is understood that Agency reserves the right to monitor Contractor's performance under this Contract by observation of the direct service provision to client(s) and/or survey of agencies or individuals purchasing or receiving services.

c. Relationship:

The relationship between Agency and Contractor is contractual only. At no time is Contractor, his/her employees or agents to be considered employees of Agency. Contractor is considered an independent contractor.

PINE COUNTY HEALTH & HUMAN SERVICES
& Rise Up Psychological Services
CLINICAL AND REFLECTIVE PRACTICE SUPERVISION SERVICES
2021

APPROVED AS TO FORM AND EXECUTION:

Pine County Attorney

Date

Chair, Pine County Board of Commissioners

Date

David J Minke
County Administrator

Date

Rebecca Foss

Director, Pine County Health & Human
Services

12/18/2020

Date

Juanita Tallman

Rise Up Psychological Services, Inc.

12/23/2020

Date



AGENDA REQUEST FORM

Date of Meeting: January 5, 2021

- County Board**
 - Consent Agenda**
 - Regular Agenda** 5 mins. ___ 10 mins. ___ 15 mins. ___ Other ___
- Personnel Committee**
- Other** _____

Agenda Item: Approve Contract for Medication Management Services

Department: HHS

Rebecca Foss
 Department Head signature

Background information on Item:

Over the last few years, Pine County Health and Human Services has contracted with Kanabec County Family Services for the provision of medication management services. Pine County HHS social workers refer children who have been diagnosed with a severe emotional disturbance to receive this service, as part of our responsibilities associated with children’s mental health case management services. HHS receives an allocation from the MN Department of Human Services that pays for the expenses associated with this service.

The attached contract is from January 1, 2021 through December 31, 2021. The rate is \$128.64/hour, which is less than a 1% increase from 2020. The County Attorney’s office has reviewed the contract.

Action Requested:

Authorize County Board Chairperson and County Administrator to sign the contract between Pine County Health and Human Services and Kanabec County Family Services.

Financial Impact:

The cost of the service is \$128.64/hour (cost shall not exceed \$10,805 annually). As noted above, HHS receives an allocation from the MN Department of Human Services which offsets the costs associated with this service.

2021 Agreement between Pine County Health & Human Services and Kanabec County Family Services
Period of Agreement: January 1, 2021 through December 31, 2021

This Agreement is made and entered into by and between Pine County Health & Human Services, with the address of 315 Main St. S., Ste 200, Pine City, MN 55063 (hereinafter the "County") and Kanabec County Family Services, with the address of 905 Forest Avenue E., Suite 150, Mora, MN 55051 (hereinafter "Kanabec County").

WITNESSETH

WHEREAS, Minn. Stat. §§245.461 through 245.486 and Minn. Stat. §§ 245.487 through 245.488 establish the Minnesota Comprehensive Adult Mental Health Act and the Minnesota Comprehensive Children's Mental Health Act, respectively;

WHEREAS, the County wishes to secure the provision of Psychiatric services; and

WHEREAS, Kanabec County is suitably structured to provide Psychiatric services, and

WHEREAS, pursuant to Minn. Statute Ch. 402, the County wishes to purchase such services from Kanabec County; and

WHEREAS, Pine County Health & Human Services wishes to serve as the Contracting Entity with Kanabec County for its provision of Psychiatric services.

NOW, THEREFORE, in consideration of the mutual understanding and agreements set forth, the County and Kanabec County agree as follows:

SECTION 1. OBLIGATIONS OF KANABEC COUNTY

- 1.1 **PROVISION OF SERVICES:** Kanabec County shall provide uninsured or underinsured residents of Pine County with Psychiatric services per host county agreement; Client's eligibility to receive such services will be mutually agreed upon by the County and Kanabec County prior to providing such service; services shall not be provided to clients who are not determined to be eligible; Determine fee for clients that have no third-party insurance, including public programs on the sliding fee schedule. Clients will be eligible for sliding fee schedule when the applicable health plans including Medical Assistance, Medicare, Minnesota Care (or its successor program), PMAP or third party payers have denied payments or reached limitations.
- 1.2 **STANDARD OF PERFORMANCE:** Kanabec County shall provide services in conformance with applicable laws and regulations and within accepted standards of professional practice; specifically, services shall conform to standards set forth in the MHCP Provider Manual as applicable to services.
- 1.3 **CAPACITY:** Kanabec County agrees to provide Psychiatric services per Agreement approved by the Pine County Board. This request is hereby incorporated in to this Agreement by this reference.
- 1.4 **PROGRAM LICENSURE:** Kanabec County shall operate as a contracted vendor in compliance with Minnesota Department of Human Services Rules.

- 1.5 HIPAA COMPLIANCE: Kanabec County shall provide and execute services in conformance with applicable regulations and standards.
- 1.6 REPORTING: Kanabec County will provide reports on a quarterly basis of services rendered as requested by the County.
- 1.7 INSURANCE: Kanabec County shall maintain general and professional liability insurance in amounts mutually acceptable to Kanabec County and the County. Kanabec County shall provide evidence of such coverage to the County upon request and shall notify the County of any proposed change or cancellation in such coverage.
- 1.8 ACCESS TO RECORDS: Consistent with federal and state requirements, Kanabec County agrees to provide access to books and records related to the Services provided under this Agreement for at least ten (10) years after the Services have been provided, upon request by the Secretary, U.S. Department of Health and Human Services, and U.S. Controller General or their representatives.
- 1.9 DISPOSITION OF ASSETS: All supplies purchased through the AMHI for this program will be for the exclusive use of this program. The intellectual rights to processes, procedures, protocols, written materials, and other products developed during this project will be held by AMHI subject to relevant state and federal laws governing such matters.
- 1.10 REQUIRED AUDITS: Regular audits will be conducted as applicable to said agency with access as requested by the County.

SECTION 2. OBLIGATIONS OF THE COUNTY

- 2.1 PAYMENT FOR SERVICES: For Psychiatric services, the payments will be based on actual expenditures not to exceed current payment rate as indicated in Appendix A. Payments for services are on a cash basis.
- 2.2 INVOICES: Upon receipt of the invoice, the County will make payment to Kanabec County within 30 days, not to exceed the current approved and authorized rate.

SECTION 3. DUTIES AND OBLIGATIONS OF BOTH PARTIES

- 3.1 DATA EXCHANGE: Both Parties acknowledge and agree that in order to deliver the Services, various types of data and confidential information will be shared between the Parties.
- 3.2 COMPLIANCE WITH LAW: Both Parties agree to take reasonable steps necessary to provide Services in accordance with all relevant federal, state and local laws and regulations including those federal and state laws and regulations relating to individuals that receive mental health services.
- 3.3 NON-DISCRIMINATION: Kanabec County will provide Services without discrimination on the basis of sex, race, creed, age, sexual orientation or nation origin.

SECTION 4. TERMINATION

- 4.1 **TERMINATION WITH CAUSE:** Either Party may terminate this Agreement for material breach, by written notice to the breaching Party; provided that such breach remains uncured for a period of thirty (30) days after receipt of written notice thereof from the non-breaching Party.
- 4.2 **TERMINAATION DUE TO CHANGE IN FUNDING:** In the event funding from the State is less than expected, decreased or terminated, the County reserves the right to give a 30-day notice of decrease or termination of this Agreement.
- 4.3 **TERMINAATION WIATHOUT CAUSE:** Either Party may terminate this Agreement without cause upon ninety (90) days written notice to the other Party.
- 4.4 **CONDITIONS OF THE PARTIES OBLIGATIONS:** It is understood and agreed that in the event the funding to the County from state and federal sources is not obtained and continued at an aggregate level sufficient to allow for the purchase of the indicated services, the obligations of each Party hereunder shall be terminated. Contractor shall neither assign nor transfer any rights or obligations under this Contract without the written consent of Pine County.
- 4.5 **OBLIGATIONS UPON TERMINATION:** Both Parties shall cooperate in any transition process necessary should the duties to be performed by Kanabec County under this Agreement be transferred to another entity.
- 4.6 **NO DISSOLUTION ASSUMED:** Termination of this Agreement, for any reason and at anytime, shall not be construed to terminate or in any way alter the relationship of the County with Kanabec County.

SECTION 5. CONFIDENTIAL INFORMATION

- 5.1 **DEFINITION:** "Confidential Information" means all proprietary or confidential information of any kind disclosed by either Party or its representatives or agents including but not limited to, any technical data or know-how, business plans, product plans or designs, products, services, client lists, provider lists, market strategies, clinical protocols, marketing information and strategies, or financial information.
- 5.2 **EXCEPTIONS:** Information will not be deemed to be Confidential Information hereunder if such information (i) becomes known, independently of disclosure by the receiving Party from a source other than one having an obligation of confidentiality toward the Confidential Information; (ii) becomes publicly known or otherwise ceases to be secret or confidential, except through a breach of this Agreement by the receiving Party; (iii) is in the possession of the receiving Party at the time of disclosure prior to disclosure by the disclosing Party (iv) become part of the public knowledge or literature, not as a result of any inaction or action of the receiving Party; or (v) is independently developed by the receiving Party without reference to the disclosing Party's Confidential Information.
- 5.3 **NONDISCLOSURE OF CONFIDENTIAL INFORMATION:** Each Party agrees that it will maintain and preserve the confidentiality of the other Party's Confidential Information, including, without limitation, taking such steps to preserve the confidentiality of the Confidential Information as it takes to preserve the confidentiality of its own Confidential Information. A

receiving Party will immediately notify the disclosing Party if it is aware of any unauthorized use or disclosure of any Confidential Information by the receiving Party, its employees or agents, or any other entity.

- 5.4 **MANDATORY DISCLOSURE:** In the event that any Party or its employees or Agents are required by legal process to disclose any of the Confidential Information of the other Party, the receiving Party shall give prompt notice to the other Party so that it may seek a protective order or other appropriate relief. In the event that such protective order is not obtained, the receiving Party shall disclose only that portion of the Confidential Information which its Counsel advises that it is legally required to disclose.
- 5.5 **NO LICENSE GRANTED:** Nothing in this Agreement is intended to grant any rights to either Party under any patent, copyright, trade secret or other intellectual property right, nor shall this Agreement grant to any Party any rights in or to the other Party's Confidential Information, except as provided herein.

SECTION 6. INDEMNIFICATION

- 6.1 **BY KANABEC COUNTY:** Kanabec County will indemnify, defend and hold the County, its director, agents, officer, and employees and assigns harmless from and against any and all costs, liabilities, losses and expenses (including , but not limited to, reasonable attorney's fees) resulting herein any claim, suit, action or proceeding against the County or its affiliates resulting from (i) a breach by Kanabec County of this Agreement; or (ii) the provision of Services by Kanabec County hereunder, including claims relating to patient care plans, protocols or standards, or (iii) violations by Kanabec County of any applicable federal, state, or local laws or regulations and any applicable terms and conditions of any contract between Kanabec County and agencies of the State of Minnesota and/or the United States of America.
- 6.2 **BY THE COUNTY:** The County will indemnify, defend and hold Kanabec County, its directors, agents, officers, and employees and assigns harmless from and against any and all costs, liabilities, losses, and expenses (including, but not limited to, reasonable attorney's fees) resulting from any claim. Suit, action, or proceeding against Kanabec County or its affiliates resulting from: (i) breach by the County of this Agreement, (ii) the provision of services, (iii) violations by the County of any applicable federal, State, or local laws or regulations and any applicable terms and conditions of any contract between the Counties and agencies of the State of Minnesota and/or the United States of America.
- 6.3 **NOTICE:** Each Party's indemnification obligations hereunder will be subject to (i) receiving prompt written notice of the existence of any potential claim, suit or action; (ii) being able to at its option, control the defense of any claim, suite or action; (iii) permitting the indemnified Party to participate in the defense of any claim, suite or action: and (iv) receiving full cooperation of the indemnified Party in the defense thereof in regards to Enhanced Psychiatric Services.

SECTION 7. MISCELLANEOUS

- 7.1 **Governing Law.** This Agreement shall be governed and construed in accordance with the laws of the State of Minnesota without giving effect to the conflicts of laws principles thereof.
- 7.2 **Assignment of Responsibilities.** Neither Party shall assign, transfer, or delegate its responsibilities

herein to any third party without the prior written consent of the other Party hereto.

- 7.3 Amendments. Neither this Agreement nor any of the terms or conditions hereof may be amended, or modified except by means of a written instrument duly executed by both Parties.
- 7.4 Entire Agreement. This Agreement, including the exhibits, constitutes the entire understanding between the Parties as to the subject matter hereof, and supersedes all prior discussions, agreements, and understandings of every kind between them as to such subject matter.
- 7.5 Independent Contractor. Notwithstanding Kanabec County and the County are independent contractors of each other. Nothing contained herein shall create or be deemed to create an employment, partnership or joint venture relationship between the Parties.
- 7.6 Assignment of rights. Neither Party shall assign, transfer or otherwise dispose of any of its rights, title or interest in, to, or under this Agreement without the prior written consent of the other Party.
- 7.7 Severability. If any provision of this Agreement is held to unenforceable for any reason, it will be modified rather than voided, if possible, in order to achieve the intent of the Parties to this Agreement to the extent possible.
- 7.8 Waiver. Any waiver will be limited to the provision hereof and the circumstance or event specifically made subject thereto and will not be deemed a waiver of any other term hereof or of the same circumstance or event upon any recurrence thereof.
- 7.9 Survival. Notwithstanding termination of this Agreement, for any reason and at any time, Sections 1.7, 6 & 7 shall survive termination.

IN WITNESS WHEREOF, the Parties have caused this Agreement to be duly executed intending to be bound thereby.

APPROVED:

COUNTY OF KANABEC

Dated: 12/14/2020

m Kelli Ellis
Kanabec County Chairperson

COUNTY OF PINE

Dated: _____

Pine County Chairperson

ATTEST:

Dated: 12/17/2020

Charles
Director, Health & Human Services

Dated: _____

Pine County Administrator

APPROVED AS TO FORM AND EXECUTION:

Dated: _____

By: _____
Pine County Attorney

Appendix A: Service Description and Payment Rate per Service:

Psychiatry Services (Mental Health Medication Management) reimbursed

Pine County will pay for (7) hours of this service per month to Kanabec County at a rate of \$128.64 per hour. Kanabec County will bill quarterly for these services.

Mental Health Medication Management

Medication management is a service to determine a recipient's needs for a prescribed drug, or to evaluate the effectiveness of the prescribed drug as noted in the recipient's written individual treatment plan. (ITP).

Medication Monitoring is a brief, face-to-face service to monitor a recipient's drug dosage or prescription.



AGENDA REQUEST FORM

Date of Meeting: January 5, 2021

- County Board**
 - Consent Agenda**
 - Regular Agenda** 5 mins. ___ 10 mins. ___ 15 mins. ___ Other ___
- Personnel Committee**
- Other** _____

Agenda Item: Approve Contract with Solid Oak Financial Services

Department: HHS

Rebecca Foss

Department Head signature

Background information on Item:

HHS has historically contracted with Solid Oak Financial Services to provide guardianship services to adults who need a guardian. The attached contract seeks to continue that working relationship with Solid Oak Financial Services in 2021. The cost of the service is increasing from \$130/month per individual to \$155/month per individual. This rate continues to be very reasonable and is less expensive than other company's rates. The department can also purchase conservatorship services as necessary.

The contract is from January 1, 2021 through December 31, 2021. It has been reviewed by the County Attorney's Office

Action Requested:

Authorize Board Chairperson and the County Administrator to sign the contract between Pine County Health and Human Services and Solid Oak Financial Services.

Financial Impact:

The expenses associated with these services are budgeted in the 2021 HHS budget.

**CONTRACT BETWEEN PINE COUNTY HEALTH AND HUMAN SERVICES
AND
Solid Oak Financial Services, LLC**

THIS AGREEMENT is made and entered into by and between the Pine County Board of Commissioners, through Pine County Health and Human Services, ("COUNTY"), 315 Main St. S, STE. 200, MN 55063 and Solid Oak Financial Services, LLC, ("CONTRACTOR"), PO Box 157, Avon, MN 56310.

WHEREAS, the COUNTY has identified a certain population who are in need of guardianship services and who are the financial responsibility of Pine County;

WHEREAS, the CONTRACTOR represents that they are duly qualified, and willing to perform such services; and

WHEREAS, the COUNTY wishes to purchase such services from the CONTRACTOR.

NOW, THEREFORE, in consideration for the mutual undertakings and agreements set forth, the COUNTY and the CONTRACTOR agree as follows:

I. Term of Agreement

The CONTRACTOR agrees to furnish services to the benefit of the COUNTY during the period commencing January 1, 2021 to December 31, 2021 irrespective of the date of signatures/execution below.

II. Services to be Provided and Reporting

The CONTRACTOR is expected to provide the services of a guardian. As a guardian, CONTRACTOR will make personal decisions on behalf of an adult under guardianship. The CONTRACTOR will be reimbursed for decision-making activities including team meetings, consultations with medical personnel, and review of legal documents etc. In addition, the CONTRACTOR will perform the following duties in her position as a guardian:

- A. The CONTRACTOR will meet face to face with the adult under guardianship at a minimum of two times per year. The CONTRACTOR will explain his/her role, responsibilities and limitations to the adult under guardianship and when possible also gain from this meeting the following:
 1. An understanding of the safety, security and suitability of the adult's living environment.
 2. A clear assessment of the adult's physical appearance, psychological state and condition of the personal item/clothing.
 3. An understanding of the adult's interests and capacity to make decisions.
- B. The CONTRACTOR will establish contact with the adult in need of guardianship's caregivers and other people who have frequent contact with the adult in need of guardianship, including family members, employer, friends and landlord if applicable.
- C. The CONTRACTOR will have telephone contact, as necessary, with the adult in need of guardianship and or his caregiver.
- D. The CONTRACTOR will provide written summaries of visits and other contacts submitted to Pine County.

- E. The CONTRACTOR will produce a Personal Well-Being Report at least annually or upon request by a judge.
- F. The CONTRACTOR will participate in person centered planning processes that honor the individual's preferences, choices and abilities which are consistent with least restrictive alternatives.
- G. The CONTRACTOR will attend annual review and re-assessment of services, if applicable.
- H. The CONTRACTOR will submit to a background check every five years.

III. In partnership, the COUNTY and CONTRACTOR will oversee the eligibility criteria, the referral process, and reporting process.

IV. Cost of the Agreement/Billing Instructions

Attached with each monthly invoice, the CONTRACTOR will provide a list of client names and dates of service to the COUNTY. Services will be billed at the following rate:

- A. Guardianship fee per client per month is \$155.00.
- B. Conservatorship fee is \$75.00 per hour of service. Conservator fee is payable by the COUNTY if the fees cannot be removed from the client's estate by the CONTRACTOR.
- C. COUNTY will provide two certified copies of Guardianship documents and Letters of Guardianship provided at no cost to CONTRACTOR for all new clients.

V. Payment for Services

Payment for services shall be made direct to the CONTRACTOR within 35 days of COUNTY's receipt of the said invoice, pursuant to Minnesota Statutes section 471.425, subdivision 2.

VI. Indemnification and Insurance

- A. CONTRACTOR agrees that in order to protect itself as well as the COUNTY, it will at all times during the term of this contract keep in force an insurance policy. This liability insurance policy will meet the limits as shown below or be equal to the tort liability limits under Minnesota Statutes section 3.736 and 466.04, subdivision 1, whichever is greater. However, should the coverage available to the CONTRACTOR exceed the liability limits, nothing by the way of that level of coverage shall be construed as a waiver of the limits available to the COUNTY. The COUNTY will be sent a current certificate of insurance on an annual basis.

- 1. Automobile Insurance (if vehicles are used to conduct this contract)

- a. Coverage shall be provided for hired, non-owned and owned autos.

- B. Any policy obtained and maintained under this clause shall provide that it shall not be cancelled, materially changed, or not renewed without thirty days prior notice to the COUNTY.

Prior to the effective date of this contract, and as a condition precedent to this contract, the CONTRACTOR will furnish the COUNTY with certificates of insurance.

- C. The CONTRACTOR agrees to defend, indemnify, and hold COUNTY, its employees and officials harmless from any claims, demands, actions or causes of action, including reasonable attorney's fees and expenses arising out of any act or omission on the party of the CONTRACTOR, or its

subcontractors, partners or independent contractors or any of their agents or employees in the performance of or with relation to any of the work or services to be performed or furnished by the vendor or the subcontractors, partners, or independent contractors or any of the agents or employees under the agreement.

VII. Compliance with Laws / Standards

- A. The CONTRACTOR shall maintain in good standing, all professional credentials necessary to provide the services contemplated and set forth herein.

- B. The CONTRACTOR shall abide by all federal, state, or local laws, statutes, ordinances, rules and regulations now in effect or hereinafter adopted pertaining to the contract or to the subject matter for which the CONTRACTOR is responsible.
 - 1. By signing this contract, the CONTRACTOR certifies that it and its principals and its employees: Are not presently debarred, suspended, proposed for debarment, declared ineligible, or voluntarily excluded from transacting business by or with any federal, state or local government department or county; and have not within a three-year period preceding this contract:
 - a. Been convicted of or had a civil judgment rendered against them for commission of fraud or a criminal offense in connection with obtaining, attempting to obtain or performing a public (federal, state or local) transaction or contract;
 - b. Violated any federal or state antitrust statutes; or
 - c. Committed embezzlement, theft, forgery, bribery, falsification or destruction of records, making false statements or receiving stolen property; and
 - 2. Are not presently indicted or otherwise criminally or civilly charged by a governmental entity for:
 - a. Commission of fraud or a criminal offense in connection with obtaining, attempting to obtain or performing a public (federal, state or local) transaction;
 - b. Violating any federal or state antitrust statutes; or
 - c. Committing embezzlement, theft, forgery, bribery, falsification or destruction of records, making false statements or receiving stolen property; and
 - 3. Are not aware of any information and possess no knowledge that any sub contractor(s) that will perform work pursuant to this contract are in violation of any of the certifications set forth above.
 - 4. Shall immediately give written notice to the COUNTY should CONTRACTOR come under investigation for allegations of fraud or a criminal offense in connection with obtaining, or perforating a public (federal, state or local government) transaction; violating any federal or state antitrust statues; or committing embezzlement, theft, forgery, bribery, falsification or destruction of records; or making false statements or receiving stolen property.

VIII. Conditions of Contractors' Obligation

- A. The CONTRACTOR agrees to inform the COUNTY of changes in ownership, organizational structure, board of director membership, and/or chief operating officers with thirty (30) days after occurrence.
- B. It is understood and agreed that in the event the funding to the COUNTY from state and federal sources is not obtained and continued to an aggregate level sufficient to allow for the purchase of the indicated quantity of Purchased Services, the obligations of each party hereunder shall be terminated.
- C. The CONTRACTOR must, within ten (10) days notify the COUNTY in writing whenever it is unable to, or going to be unable to, provide the required quality or quantity of Purchased Services. Upon such notification, the COUNTY must determine whether such inability will require modification or cancellation of said contract.
- D. Either party may cancel this contract with or without cause upon sixty (60) days written notice. Written notice of cancellation by the CONTRACTOR shall be addressed to Director, Pine County Health and Human Services, 315 Main Street South Suite 200, Pine City, MN 55063.
- E. Before the termination date of the contract, the COUNTY may evaluate the contract performance of the CONTRACTOR and determine whether such performance merits renewal of this contract.
- F. The COUNTY will reimburse for services specified in this contract that have been delivered. Any alterations, variations, modifications or waivers of provisions of this contract shall be valid only when they have been reduced to writing, duly signed, and attached to the original contract.
- G. If the COUNTY determines that funds are not being administered in accordance with the approved service plan and budget or that services are not being properly provided according to the terms of this contract, the COUNTY may terminate this contract after notice has been provided to the CONTRACTOR's designated agent.

IX. Independent Contractor

- A. The CONTRACTOR is an independent contractor and neither the position nor the work of the CONTRACTOR shall cause the CONTRACTOR to be construed as an employee in any way. The CONTRACTOR shall at all times be free to exercise initiative, judgment and discretion as to how to best perform or provide services.
- B. The CONTRACTOR acknowledges and agrees that it is not entitled to receive any of the benefits received by COUNTY employees and is not eligible for workers or unemployment compensation benefits.
- C. The CONTRACTOR also acknowledges and agrees that no withholding or deduction for state or federal income taxes, FICA, FUTA, or otherwise, will be made from the payments due and that it is the CONTRACTOR's sole obligation to comply with the applicable provision of all federal and state laws.

X. Data Practices

All data collected, created, received, maintained, or disseminated for any purposes by the activities of CONTRACTOR because of this contract is governed by the Minnesota Government Data Practices Act, Minnesota Statutes Chapter 13, as amended, the Minnesota Rules implementing said act now in force or as adopted, as well as HIPAA or other federal regulations on data privacy.

XI. Records-Availability and retention

- A. Pursuant to Minnesota Statutes section 16C.05 subdivision 5, the CONTRACTOR agrees that the COUNTY, the State Auditor, or any of their duly authorized representatives at any time during normal business hours and as often as they may reasonably deem necessary, shall have access to and the right to examine, audit, excerpt, and transcribe any books, documents, papers, records, etc., which are pertinent to the accounting practices and procedures of the CONTRACTOR and involve transaction relating to the contract.
- B. CONTRACTOR agrees to maintain these records for a period of six (6) years from the date of termination of the contract.
- C. CONTRACTOR will maintain client and placement records according to business standard practices.

XII. Audit and Record Disclosures

The CONTRACTOR agrees to:

- A. Provide review of adults under guardianship at the end of December of 2021.
- B. Maintain all records pertaining to the contract at address of CONTRACTOR for six (6) years for audit purposes.

XIII. Contractor Qualifications and Training

- A. The CONTRACTOR agrees to use only qualified personnel to provide any purchased services. If licensing or certification is a necessary prerequisite for provision of services, the CONTRACTOR shall ensure that personnel are properly licensed or certified.
- B. The CONTRACTOR agrees to provide or arrange for staff training as required.
- C. A copy of the staff training plan shall be provided to the COUNTY upon request.
- D. A background check satisfactory to the COUNTY will be performed on all employees prior to unsupervised client contact in accordance with Minnesota Department of Human Services.
- E. The CONTRACTOR agrees to maintain at all times during the term of the contract, a process whereby its current and prospective employees and volunteers who will have direct contact with persons served by the program or program services, will consent to a background check for evidence of maltreatment of adults or minors substantiated under Minnesota Statutes section 626.556.

XIV. Subcontracting

CONTRACTOR shall not enter in any subcontract for performance of any services contemplated under the contract without the knowledge of the COUNTY and subject to such conditions and provisions as the COUNTY may deem necessary. With regard to any subcontractors so retained the CONTRACTOR shall be responsible for the performance under this contract and agrees to comply with prompt payment of any and all subcontractors pursuant to Minnesota Statutes section 471.425, subdivision 4a.

XV. Nondiscrimination

During the performance of this agreement, the CONTRACTOR agrees to the following:
No person shall, on the grounds of race, color, religion, age, sex, disability, marital status, public assistance status, creed or national origin be excluded from full employment rights in, participation in, be

denied the benefits of or be otherwise subjected to discrimination under any and all applicable federal and state laws against discrimination.

XVI. Representatives

The following named persons are designated the authorized representatives of parties for purposes of this contract. These persons have authority to bind the party they represent and to consent to modifications and subcontracts, except that, as to the COUNTY, the authorized representative shall have only the authority specifically or generally granted to the County Board of Commissioners. Notification required to be provided pursuant to the contract shall be provided to the following named persons and addresses unless otherwise stated in the contract, or in a modification of this contract.

County Designee: Patrick Meacham, Adult Social Services Supervisor
Pine County Health and Human Services
315 Main Street S Suite 200
Pine City, MN 55063
320-216-4119

Contractor Designee: Bernard Neubauer
Solid Oak Financial Services, LLC
PO Box 157
Avon MN 56310
320-291-6442

XVII. Modifications

Any alterations, variations modifications, or waivers of provisions of this agreement must be valid only when they have been reduced in writing, duly signed, and attached to the original of this agreement. No claim for services furnished by CONTRACTOR not specifically provided in the agreement will be allowed by the COUNTY nor must the CONTRACTOR do any work or furnish any material not covered by the agreement, unless this is approved in writing by the COUNTY. Such approval must be considered a modification of the agreement.

IN WITNESS THEREOF, the COUNTY and the CONTRACTOR, each intending to be bound by this agreement, effective January 1, 2021 irrespective of the dates of the signatures, certifies that the appropriate person have executed the contract, as required by applicable articles, by-laws resolutions and ordinances.

COUNTY OF PINE STATE OF MINNESOTA

DIRECTOR COUNTY SOCIAL SERVICE AGENCY

BY: _____
Chairperson, Board of Commissioners

BY: Rebecca Foss
Rebecca Foss, Director of Health and Human Services

DATED: _____

DATED: 12/29/2020

ATTESTED TO:

CONTRACTOR

BY: _____
David J. Minke, Pine County Administrator

BY: _____
Bernard Neubauer

DATED: _____

DATED: _____

APPROVED AS TO LEGALITY AND FORM:

BY: _____
Reese Frederickson, Pine County Attorney

DATED: _____



AGENDA REQUEST FORM

Date of Meeting: January 5th, 2021

- County Board**
 - Consent Agenda**
 - Regular Agenda** 5 mins. ___ 10 mins. ___ 15 mins. ___ Other ___
- Personnel Committee**
- Other** _____

Agenda Item: Septic Fix-Up Special Assessments

Department: Auditor-Treasurer



 Department Head signature

Background information on Item:

Beginning in 2016, Pine County has been extending loans to homeowners to upgrade their non-compliant septic systems through a Cleanwater Partnership Loan from the Minnesota Pollution Control Agency. A new loan cycle began August 1st with \$900,000 available at 1% interest. The loans are paid by as a special assessment on the property taxes of the benefiting property over a term that is determined by the amount of the loan (1 year per \$1,000, for example \$12,000 loan is paid by over 12 years.)

Beginning in 2013, Pine County has been assisting low and moderate income homeowners to upgrade their non-compliant septic systems through funds received from the Minnesota Pollution Control Agency. This program is facilitated through a partnership with Lakes & Pines. Low income homeowners receive a no-interest, no payment loan which if they live in the home for 10 is forgiven, and moderate income homeowners receive a no-interest, 10-year special assessment.

Action Requested:

Consider authorizing the County Board Chair and County Administrator to sign Resolution 2021-01 extending a special assessment as follows:

Paul E. Jerry, PID 17.0256.000, \$13,280

Shawn Kilpela & Stacie Mix, PID 43.0552.000, \$11,496.21

Ralph O. Baker and Gloria J. Baker, PID 26.0049.000, \$5,750.00

Michael T. Belland and Michelle M. Belland, PID 26.8800.300, \$5,750.00

Clifford McCann, PID 31.0020.001, \$15,800.00

Kevin W. Dahl and Paula K. Dahl, PID 43.0608.001, \$24,500.00

Financial Impact:

Grant funds have been utilized to install the systems.

Contract Number: 1901
Pay Request Number: 4

Project Number SAP 058-632-018	Project Description Bridge #58557 and Approach Grading
--	--

Contractor: S & R Reinforcing, Inc. 44216 Tame Fish Lake Road Aitkin, MN 56431	Vendor Number: 5875 Up To Date: 12/10/2020 Warrant # _____ Date _____
---	---

Contract Amount		Funds Encumbered	
Original Contract	\$550,535.80	Original	\$550,535.80
Contract Changes	\$-16,181.40	Additional	N/A
Revised Contract	\$534,354.40	Total	\$550,535.80

Work Certified To Date	
Base Bid Items	\$580,480.45
Contract Changes	\$-16,181.40
Material On Hand	\$0.00
Total	\$564,299.05

Work Certified This Request	Work Certified To Date	Less Amount Retained	Less Previous Payments	Amount Paid This Request	Total Amount Paid To Date
\$5,107.34	\$564,299.05	\$0.00	\$531,232.12	\$33,066.93	\$564,299.05
Percent: Retained: 0%				Percent Complete: 105.6%	

This is to certify that the items of work shown in this certificate of Pay Estimate have been actually furnished for the work comprising the above-mentioned projects in accordance with the plans and specifications heretofore approved.

Approved By 

 County/City/Project Engineer
 Date 12/11/20

Approved By S & R Reinforcing, Inc.

 Contractor
 Date

Project No.: SAP 058-632-018
Final Pay Request No.: 4
Contract No.: 1901

Certificate of Final Contract Acceptance
Final Voucher Number: 4

This is to certify that to the best of my knowledge, the items of work shown in the Statement of Work Certified herein have actually furnished in accordance with the Plans and Specifications. This Project has been completed in accordance with the Laws, Standards and Procedures of as they apply to projects in this category, and if applicable, approved by the Federal Highway Administration.

Dated 12/20/20 Signature Maria Lopez County/City/Project Engineer

The undersigned Contractor hereby certifies that the work described has been performed in accordance with the terms of the Contract, and agrees that the Final Value of Work Certified on this Contract is \$564,299.05 and agrees to the amount of \$33,066.93 as Final Payment on this Contract in accordance with this Final Voucher.

Contractor: S & R Reinforcing, Inc.

By Christine Strohmayer

And _____ And _____ State of, MA

On This 22 Day Dec, 2020, Before me appeared Christine Strohmayer to me known to

(Individual Acknowledgment)

be the person who executed the foregoing Acceptance and Acknowledged that he/she executed the same as _____ free to act and deed

(Corporate Acknowledgment)

Christine Strohmayer And _____, to me personally known, who, being each by me duly sworn

each did say that they are respectively the President and _____ of the

S & R Reinforcing Inc. Corporation named in the foregoing instrument, and that the seal affixed to said instrument is the Corporate Seal of said Corporation, and the said instrument was signed and sealed in behalf of said Corporation by authority of its

President and said _____ and _____

acknowledged said instrument to be the free act and deed of said Corporation.

Notarial My Commission as Notary Public in Aitkin County

Seal Expires 01-31-2024 Signature Debra Haroldson



I hereby certify that a Final Examination has been made of the noted Contract, that the Contract has been completed, that the entire amount of Work Shown in this Final Voucher has been performed and the Total Value of the Work Performed in accordance with, the terms of the Contract is as shown in this Final Voucher.

This Contract is hereby accepted in accordance with the Specification 1516. Final acceptance of the Contract will be effective upon full Execution, by the Contractor and the Department, of the "Certificate of Final Acceptance" included with the Final Voucher.

Dated _____ Signature _____ District Engineer

Project No.: SAP 058-632-018
Final Pay Request No.: 4
Contract No.: 1901

**Certificate of Final Contract Acceptance
Final Voucher Number: 4
County Board Acknowledgement**

Contract Number: 1901
Contractor: S & R Reinforcing, Inc.
Date Certified: 12/10/2020
Payment Number: 4

Whereas; Contract No. 1901 has in all things been completed, and the County Board being fully advised in the premises, now then be it resolved; that we do hereby accept said completed project for and in behalf of the Pine County Public Works and authorize final payment as specified herein.

Pine County Public Works

State of Minnesota

I, David J Minke, County Administrator within and for said county do hereby certify that the foregoing resolution is a true and correct copy of the resolution on file in my office.

Dated this 5th day of January, 2021

At Pine City MN

Signed by _____

County Administrator

Payment Summary					
No.	Up To Date	Work Certified Per Request	Amount Retained Per Request	Amount Paid Per Request	
1	2019-08-10		301,735.39	15,086.77	286,648.62
2	2019-09-14		196,843.72	9,842.19	187,001.53
3	2019-10-21		60,612.60	3,030.63	57,581.97
4	2020-12-10		5,107.34	-27,959.59	33,066.93

Funding Category Name	Funding Category Number	Work Certified to Date	Less Amount Retained	Less Previous Payments	Amount Paid this Request	Total Amount Paid to Date
Sales Tax	0	564,299.05	0.00	531,232.12	33,066.93	564,299.05

Accounting Number	Funding Source	Amount Paid this Request	Revised Contract Amount	Funds Encumbered to Date	Paid Contractor to Date
0321	Local	33,066.93			564,299.05

Contract Item Status										
Project	Line	Item	Description	Units	Unit Price	Contract Quantity	Quantity This Request	Amount This Request	Quantity To Date	Amount To Date
SAP 058-632-018	1	2021.501/00010	MOBILIZATION	LS	41,000.00	1	0	0.00	1	41,000.00
SAP 058-632-018	2	2401.503/08400	TYPE S (TL-4) BARRIER CONC (3S52)	LF	157.60	159	0	0.00	159	25,058.40
SAP 058-632-018	3	2401.507/03643	STRUCTURAL CONCRETE (3B52)	CY	805.00	69	0	0.00	69	55,545.00
SAP 058-632-018	4	2401.508/00011	REINFORCEMENT BARS (EPOXY COATED)	LB	1.31	29160	14	18.34	29160	38,199.60
SAP 058-632-018	5	2401.601/00060	SLOPE PREPARATION	LS	5,000.00	1	0	0.00	1	5,000.00
SAP 058-632-018	6	2401.601/00010	STRUCTURE EXCAVATION	LS	21,623.00	1	0	0.00	1	21,623.00
SAP 058-632-018	7	2401.618/04001	BRIDGE SLAB CONCRETE (3YHPC-M)	SF	31.00	3123	0	0.00	3123	96,813.00
SAP 058-632-018	8	2402.502/07061	FLOOR DRAIN TYPE B706 MODIFIED	EACH	1,400.00	2	0	0.00	2	2,800.00
SAP 058-632-018	9	2402.502/08101	ELASTOMERIC BEARING PAD TYPE 1	EACH	128.00	10	0	0.00	10	1,280.00
SAP 058-632-018	10	2402.508/00010	STRUCTURAL STEEL (3306)	LB	4.50	730	0	0.00	730	3,285.00

Contract Item Status										
Project	Line	Item	Description	Units	Unit Price	Contract Quantity	Quantity This Request	Amount This Request	Quantity To Date	Amount To Date
SAP 058-632-018	11	2405.503/00916	PRESTRESSED CONCRETE BEAMS 36M	LF	230.00	395	0	0.00	395	90,850.00
SAP 058-632-018	12	2405.503/05036	DIAPHRAGMS FOR TYPE 36M PREST BEAMS	LF	110.00	34	0	0.00	34	3,740.00
SAP 058-632-018	13	2452.502/09040	STEEL H-TEST PILE 40 FT LONG 10"	EACH	4,570.00	2	0	0.00	2	9,140.00
SAP 058-632-018	14	2452.502/20100	PILE TIP PROTECTION 10"	EACH	100.00	12	0	0.00	13	1,300.00
SAP 058-632-018	15	2452.603/10100	STEEL H-PILING 10"	LF	31.67	300	0	0.00	283.5	8,978.45
SAP 058-632-018	16	2502.501/00010	DRAINAGE SYSTEM TYPE (B910)	LS	1,000.00	1	0	0.00	1	1,000.00
SAP 058-632-018	17	2511.504/00017	GEOTEXTILE FILTER TYPE 7	SY	3.00	650	0	0.00	493	1,479.00
SAP 058-632-018	18	2511.507/00014	RANDOM RIPRAP CLASS III	CY	60.00	321	0	0.00	312	18,720.00
SAP 058-632-018	19	2563.601/00010	TRAFFIC CONTROL	LS	2,800.00	1	0.5	1,400.00	1	2,800.00
SAP 058-632-018	20	2101.501/00020	CLEARING & GRUBBING	LS	1,500.00	1	0	0.00	1	1,500.00
SAP 058-632-018	21	2104.503/00255	REMOVE PIPE CULVERTS	LF	10.00	29	0	0.00	29	290.00
SAP 058-632-018	22	2105.507/00015	COMMON EXCAVATION	CY	10.00	335	0	0.00	335	3,350.00
SAP 058-632-018	23	2105.507/00360	COMMON BORROW (LV)	CY	14.00	3752	0	0.00	5940	83,160.00
SAP 058-632-018	24	2118.507/00150	AGGREGATE SURFACING (CV) CLASS 5	CY	28.00	627	0	0.00	632	17,696.00
SAP 058-632-018	25	2442.501/00010	REMOVE EXISTING BRIDGE	LS	18,296.00	1	0	0.00	1	18,296.00
SAP 058-632-018	26	2501.502/04036	36" GS PIPE APRON	EACH	550.00	2	0	0.00	2	1,100.00
SAP 058-632-018	27	2501.503/13362	36" RC PIPE CULVERT	LF	44.50	44	0	0.00	44	1,958.00
SAP 058-632-018	28	2573.503/00023	SILT FENCE; TYPE MS	LF	3.00	1535	264.5	793.50	529	1,587.00

Contract Item Status										
Project	Line	Item	Description	Units	Unit Price	Contract Quantity	Quantity This Request	Amount This Request	Quantity To Date	Amount To Date
SAP 058-632-018	29	2573.503/00031	FLOTATION SILT CURTAIN TYPE MOVING WATER	LF	20.00	240	0	0.00	300	6,000.00
SAP 058-632-018	30	2575.501/00020	TURF ESTABLISHMENT	LS	1,800.00	1	0.6	1,080.00	1.1	1,980.00
SAP 058-632-018	31	2575.504/00073	EROSION CONTROL BLANKETS CATEGORY 3N	SY	3.50	3202	383	1,340.50	4272	14,952.00
SAP 058-632-018	32	2575.505/00055	RAPID STABILIZATION METHOD 1	ACRE	2,240.00	0.67	0	0.00	0	0.00
Base Bid Totals:								\$4,632.34		\$580,480.45

Project Category Totals			
Project	Category	Amount This Request	Amount To Date
SAP 058-632-018	PARTICIPATING	1,418.34	428,611.45
SAP 058-632-018	NON-PARTICIPATING	3,214.00	151,869.00

Contract Change Item Status												
Project	CC	CC#	Line	Item	Description	Units	Unit Price	Contract Quantity	Quantity This Request	Amount This Request	Quantity To Date	Amount To Date
SAP 058-632-018	BK	1	33	2575.523/00020	RAPID STABILIZATION METHOD 3	MGAL	726.00	1	0	0.00	1	726.00
SAP 058-632-018	CO	1	34	2105.607/00011	COMMON BORROW MATERIAL COST (LV)	CY	-1.15	5940	0	0.00	5940	-6,831.00
SAP 058-632-018	CO	1	35	2105.607/00012	SELECT GRANULAR BORROW MATERIAL COST (LV)	CY	-1.15	1036	0	0.00	1036	-1,191.40
SAP 058-632-018	CO	1	36	2511.607/00029	RANDOM RIPRAP CLASS III MATERIAL COST	CY	-30.00	312	0	0.00	312	-9,360.00
SAP 058-632-018	BK	2	37	2574.507/00100	COMMON TOPSOIL BORROW	CY	47.50	10	10	475.00	10	475.00
Contract Change Totals:										\$475.00		\$-16,181.40

Contract Total	564,299.05
-----------------------	-------------------

Contract Change Totals			
Number	Description	Amount This Request	Amount To Date
BK 2	Placed 10 yds Common topsoil borrow for filling washouts. Determined contract unit price from recent contract unit prices.	475.00	475.00
CO 1	During construction it has been agreed that the subcontractor shall be allowed to use a nearby county pit as its source for the Common Borrow (LV), Select Granular Borrow (LV) needed to construct the road approaches to the bridge and Random Riprap Class III needed for slope protection at the bridge abutments. The cost to purchase Common Borrow (LV) and Select Granular Borrow (LV) from the county shall be \$1.15/cu. yd. and to purchase Random Riprap Class III from the county shall be \$30.00/cu. yd.	0.00	-17,382.40
BK 1	During construction it has been determined to use Rapid Stabilization Method 3 to control erosion of exposed soil piles on the project. This Rapid Stabilization Method 3 shall be placed as per specification 2575.3M Rapid Stabilization and 2575.3M.1.c Method 3. This work shall be paid for under item 2575.523 Rapid Stabilization Method 3 at the unit price shown in the Special Provisions of section S-24 (2575) Establishing Turf and Controlling Erosion of \$726.00 / M Gallon.	0.00	726.00

Material On Hand Additions					
Line	Item	Description	Date	Added	Comments

Material On Hand Balance						
Line	Item	Description	Date	Added	Used	Remaining



AGENDA REQUEST FORM

Date of Meeting: January 5, 2021

- County Board**
 - Consent Agenda**
 - Regular Agenda** 5 mins. ___ 10 mins. ___ 15 mins. ___ Other ___
- Personnel Committee**
- Other** _____

Agenda Item: Legal Description Course

Department: Auditor-Treasurer

Kelly M. Shea
Department Head signature

Background information on Item:

One set of skills that is required in the Auditor-Treasurer’s office which very few people come to working in the office with are the ability to read/interpret legal descriptions. The office will have a new Clerk III starting on January 11, 2021 who has these skills, but needs a good refresher of them.

Action Requested:

Consider Jacqueline Ness, Clerk III in the Auditor-Treasurer’s office to attend the virtual Pro-West Legal Description Training hosted by the Minnesota Counties Computer Cooperative. The training has been pre-recorded so it can be completed at anytime; however, it is intended that Jackie will complete the training within her first working days (January 11-12, 2021).

Financial Impact:

The cost of the Legal Description Training is \$180 with no travel expenses due to the training being held virtually. All expenses are within the 2021 Auditor-Treasurer’s office budget.



AGENDA REQUEST FORM

Date of Meeting: January 5, 2021

- County Board**
 - Consent Agenda
 - Regular Agenda 5 mins. xxx 10 mins. ___ 15 mins. ___ Other ___
- Personnel Committee**
- Other** _____

Agenda Item: Acknowledgement of 50 years of county employment

Department: HHS

Rebecca Foss

Department Head signature

Background information on Item:

On January 6, 2021, HHS Office Manager Janet Schumacher will be celebrating 50 years of employment with Pine County. HHS would like to take a minute and acknowledge this significant milestone.

Action Requested:

Acknowledge Janet Schumacher's 50 years with Pine County.

Financial Impact:

N/A



AGENDA REQUEST FORM

Date of Meeting: 1/5/2021

- County Board**
 - Consent Agenda
 - Regular Agenda 5 mins. ___ 10 mins. ___ 15 mins. ___ Other ___
- Personnel Committee**
- Other** ___

Agenda Item: Introduction of Paul Swanson, Interim SWCD District Manager

Department: Administration

Department Head signature

Background information on Item:

Paul Swanson has been appointed the interim district manager for the Pine Soil and Water Conservation District. Paul was hired as the district forester in April 2018 and has been functioning as the interim director since September.

Paul grew up in southern Wisconsin and has a Bachelor of Science degree in Forest Resources from the University of Minnesota—Twin Cities. After college Paul worked in California, but then moved back to the Midwest and prior to being hired by Pine SWCD, was working for the Fond du Lac Reservation Resource Management Department.

While serving as the district forester Paul has implemented or expanded many programs including forestry stewardship plan writing, backpack sprayer rental, Arbor Day tree sales, and outreach and education.



AGENDA REQUEST FORM

Date of Meeting: _____

- County Board**
 - Consent Agenda
 - Regular Agenda 5 mins. ___ 10 mins. ___ 15 mins. ___ Other ___
- Personnel Committee**
- Other** _____

Agenda Item: _____

Department: _____

Department Head signature

Background information on Item:

Action Requested:

Financial Impact:



Pine County Extension Ag Educator Update

Rod Greder, Ph.D.
Extension Educator





PINE COUNTY AGRICULTURE

Pine County has 823 farms (down 5%) according to the 2017 Census of Agriculture with 160,623 acres in farms (down 20%). Average farm size is 195 acres. Market value of all products is at \$39B, down 40% from 2012.

Pine County ranks 57^h of 87 in livestock production in Minnesota and is 59th in beef cattle and 36th in dairy cattle. The county ranks 40th (14th in 2012) in horses and 51st in sheep and lambs.

For crop production the county ranks 76th overall, 6th (2nd) in cut Christmas trees, 18th (12th) in greenhouse, nursery and sod, The county is also 11th for aquaculture. **Pine also ranks high for forage land for all hay, haylage, grass silage and green chop (highest crop category, 5th - 2012).**

Assessment & Planning

Initial conclusions after reviewing the agricultural statistics in the first section above indicate traditional priorities to be: beef and dairy cattle; hay, pasture and other forages. In addition, needs of Christmas tree growers, greenhouse, nursery and sod producers as well as aquaculture should be determined and addressed as needed.

Planning

Needs Assessment

- Determine size and significance of the problem – secondary research
- Interview farmers to understand issue – primary research
- Determine appropriate solution – classroom workshop, field day, publication, pasture walk, online content?

Partnerships

- Determine stakeholders
- Approach other agencies and suppliers
- Explore sponsorships and partnerships



Pine County Farmer Needs Assessment-2017

Business Planning Importance to Farm Business (% of Pine County Farmers that identified 4 & 5)

— Retirement and Farm Transition	62.9%
— Business Tools	48.5%
— Budgeting	48.5%

Business Development Importance to Farm Business (% of Pine County Farmers that identified 4 & 5)

— Marketing	62.9%
— Value Added Agriculture	60.0%
— Reduced Input	54.3%
— Beginning Farmer Edu. & Networking	51.4%

Production-Husbandry Importance to Farm Business (% of Pine County Farmers that identified 4 & 5)

— Animal Health	80.0%
— Cow/Calf Management	77.1%
— Cow/Calf Nutrition	71.4%
— Reproduction & Genetics	65.7%
— Feedlot Management	54.3%
— Feedlot Nutrition	54.3%
— Dairy Beef/Organic	37.1%

Pine County Farmer Needs Assessment-2017

Production-Husbandry Importance to Farm Business (% of Pine County Farmers that identified 4 & 5)

— Pasture & Forage Management	80.0%
— Soil Health	80.0%
— Manure & Nutrient Management	71.4%
— Pest Management	48.5%
— Corn	40.0%
— Small Grains	28.6%
— Specialty Crops	28.6%
— Soybeans	20.0%

Method of Preferred Education Delivery

— Winter Workshop (2-3 hours, 1-2 speakers)	54.3%
— Summer On farm Tours/Field Days	45.7%
— One-on-One Meetings	40.0%
— Winter Workshop (4-6 hours, 3-5 speakers)	22.8%
— Online Learning Modules	22.8%
— Webinars	20.0%
— Smartphone Apps	8.6%

Planning – Assessing Need

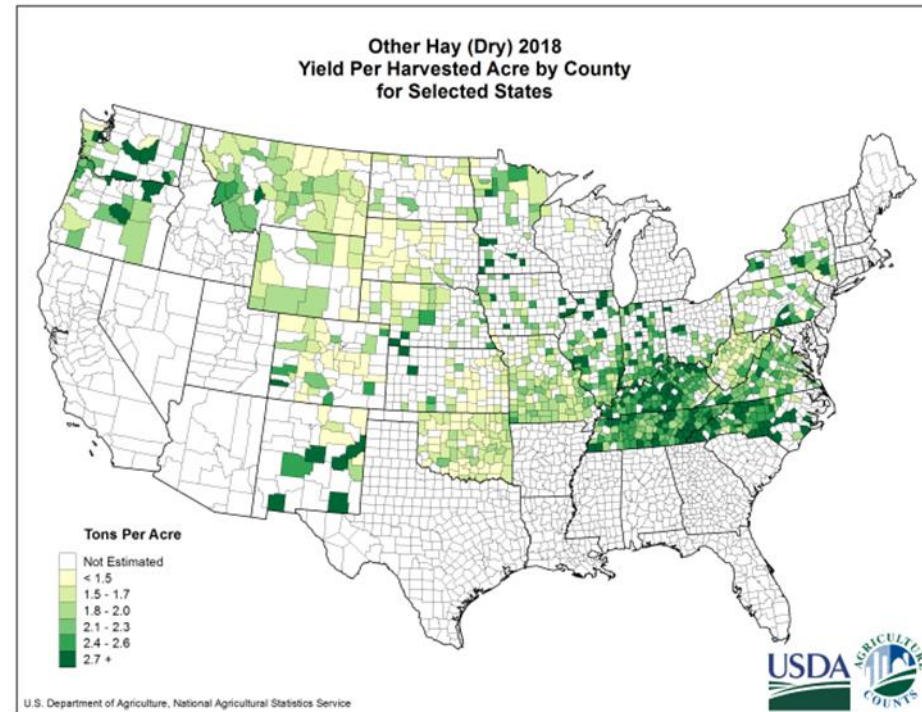
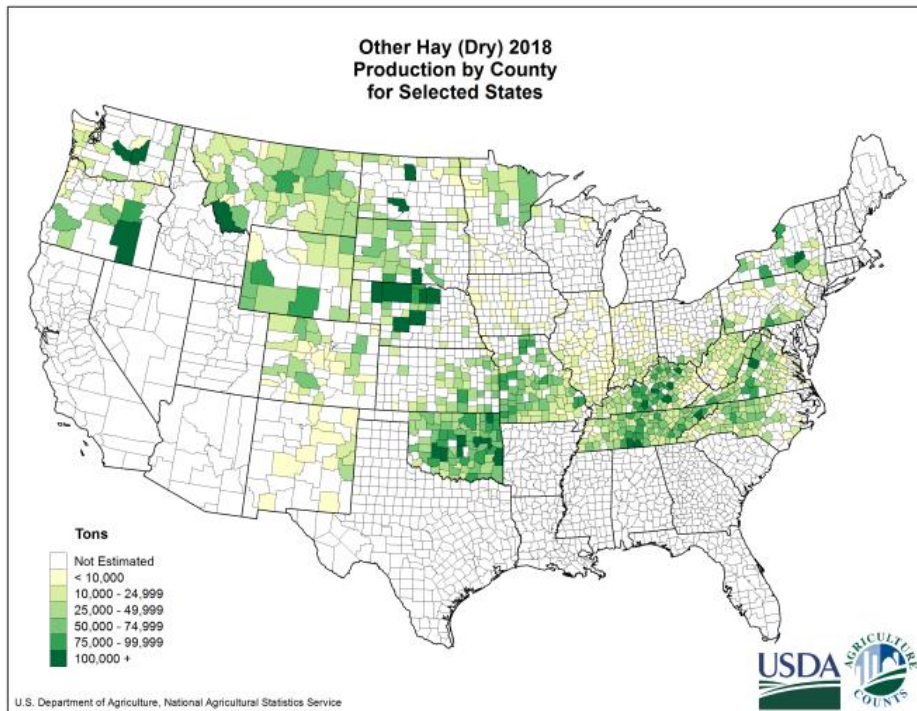

https://www.nass.usda.gov/Charts_and_Maps/Crops_County/oh-yi.php

2020 Field Days/Events/Training/Education

Field Days – Pine County



- Farm Safety quick tips-FB posts
- Soil Health Day-Jon Stevens, Aug 21st
- Site Visits/Consultations – 15+ (25 phone, email)



FARMLAND RENTAL WORKSHOP

East Central Regional Meeting
December 11 at 9:00 - 11:00 AM

 UNIVERSITY OF MINNESOTA EXTENSION



Small Farm Start-up School, Oct 21-Dec 16

Pine Ag Extension is offering a Small Farm Education series in Fall/Winter 2020. We have 15 farm families in the 5th week of the 8 week series. All content is delivered online via a Canvas self-paced course room and weekly live Zoom discussions. Farm tours and farmer Q&A panels are also included. All participants are required to write a business plan.

Class will be offered again in March, 2021. Five families are waitlisted.

For more information:

<https://local.extension.umn.edu/local/pine/county-agriculture-educator/article/small-farm-education-workshop-series>

UNIVERSITY OF MINNESOTA EXTENSION

2020 Small Farm Start-up School

Modules

- 📁 ? [Course Information and Help](#)
- 🕒 (Online) [Week 1 - Taking Stock-Planning & Setting Goals - Oct 21](#)
- 🌐 [Farm Tours - October 24](#)
- 📍 (Online) [Week 2 - What Can I Do with My Property?-Oct 28](#)
- 💧 (Online) [Week 3 - Soil, Water, Air, Climate-Nov 4](#)
- 🚗 (Online) [Week 4 - Buildings/Equipment/Crops-Nov 11](#)
- 🌲 (Online) [Week 5 - Woods, Wetlands and Wildlife-November 18](#)
- 📄 [Breaking News Archive](#)



Outreach (in Covid-19 times)

Social media/Website/Radio/Print:

Created Pine County Ag Extension FB page on March 24. Currently have 160 followers.

Please like/follow/share!

<https://www.facebook.com/pine.county.extension>

Created Pine County Ag page on local extension site with updates on crops and livestock.

<https://local.extension.umn.edu/local/pine-county/county-agriculture-educator>

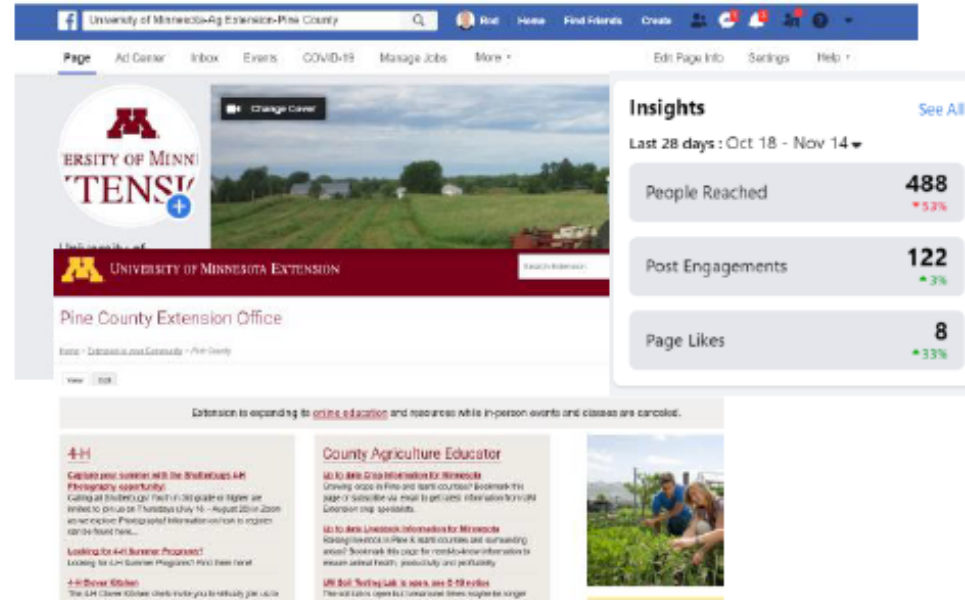

Listen to the Pine County Extension Ag report on WCMP 100.9 at 5:30 on Friday, November 27th. We will discuss “winter feeding plans and harvest update” and other timely topics. <https://www.wcmpradio.com/> I am on every other Friday.

2021 Field Days/Events/Training/Education

Field Days/Education – Pine County

- **2021 Small Farm Start-up School – March 10**
- **Crops Day, March 5th**
- **Farm Safety – 4H Summer**
- **Pasture/Hay Field Days**
- **Cow-Calf Beef Day**
- **Local Food Day**
- **Technical Assistance**

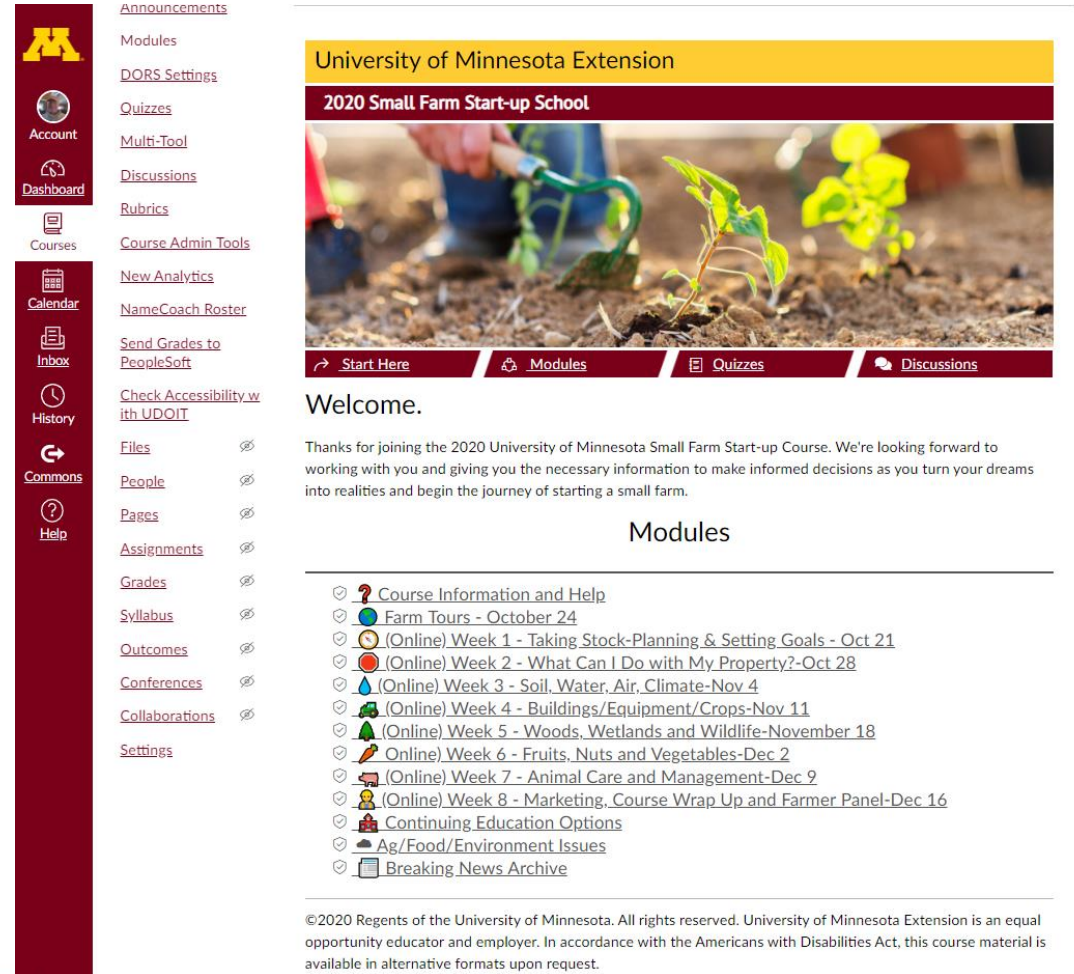

The screenshot shows a Blackboard course interface. On the left is a vertical navigation menu with icons for Account, Dashboard, Courses, Calendar, Inbox, History, Commons, and Help. The main content area has a yellow header for 'University of Minnesota Extension' and a dark red banner for '2020 Small Farm Start-up School'. Below the banner is a photo of hands planting a seedling. A navigation bar contains 'Start Here', 'Modules', 'Quizzes', and 'Discussions'. The 'Welcome.' message thanks the user for joining the course. The 'Modules' section lists various topics with icons, including 'Course Information and Help', 'Farm Tours - October 24', and several weekly modules from October to December. A footer contains copyright information for the University of Minnesota.

Grants (Research and Education in Pine County 2017-21)



Pasture Productivity Pail



Pasture Productivity Pail contains –

1. Pasture productivity booklet,
2. Grazing stick,
3. Pasture condition score sheet/guide to pasture condition scoring,
4. Soil thermometer,
5. Soil moisture meter
6. Compaction meter (optional),
7. Pasture grasses and legumes identification sheet (Plant Snap App),
8. Soil test bags, probe and instructions,
9. Refractometer and grips (optional),
10. Pasture weed ID chart (ID Weeds app),
11. Photo gallery of legume content
12. NRCS grazing record-keeping chart (or App like Pasture Map)
13. Clipboard, notebook and pencil.

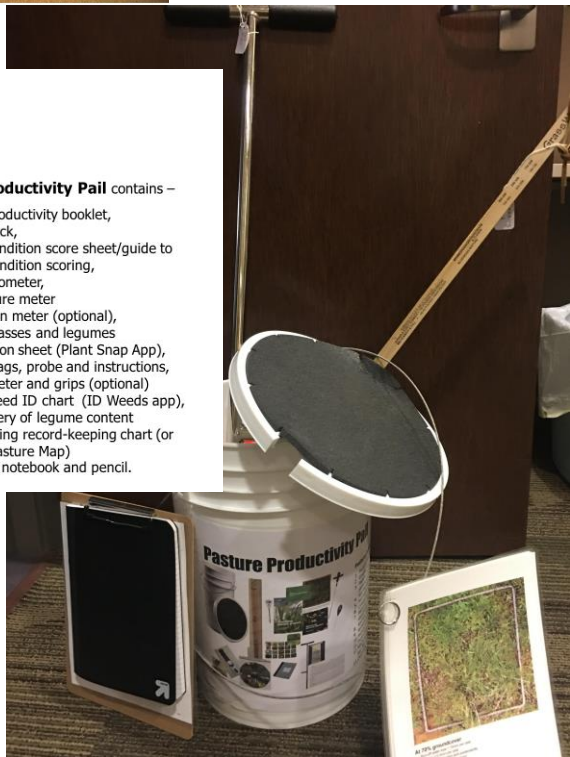

Mobile Unit to facilitate rotational grazing

12 - What are you providing for cattle and calves in each paddock, check all that apply. .

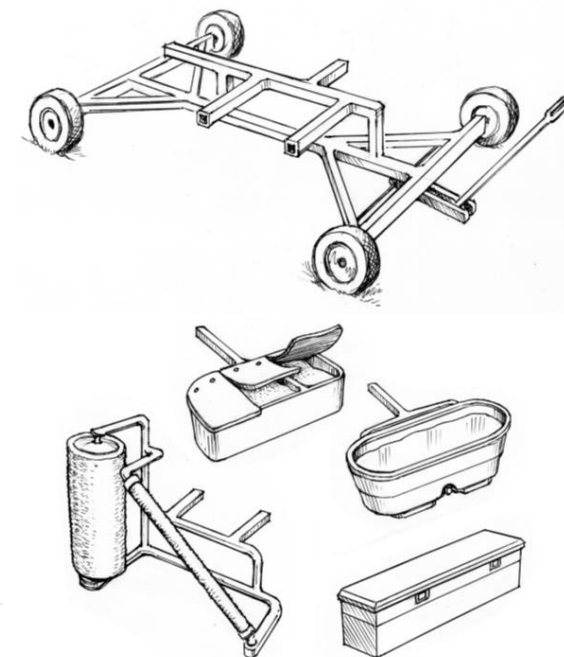
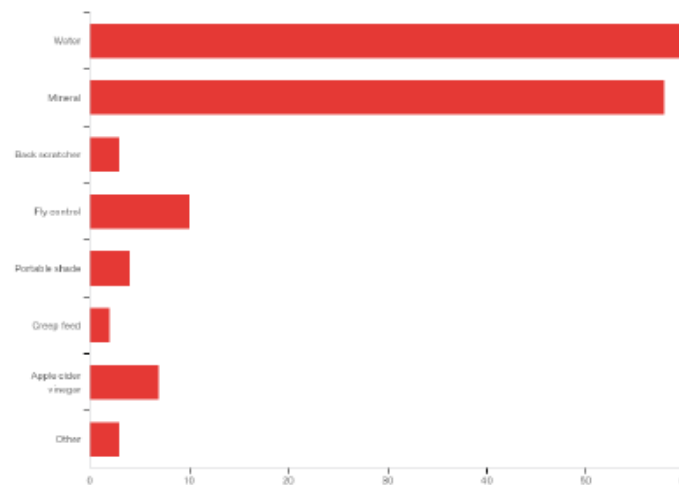

Soil Health and Pasture Productivity Tools

Pine County Ag Development Proposal

Agriculture Economic Development Plan 2021-2023 (DRAFT)

Objective – Increase number and success of new agribusinesses

- Small Farm Start-up School
- Brochure to promote Pine County Ag
- Partner with other stakeholders – Mille Lacs Band
- Targeted marketing campaign
- Package of meaningful incentives

Objective: Promote Pine County as a viable destination for establishment of small farms, market gardens, agritourism and other food-based on-farm businesses.

Working assumptions: For reasons that include: a number of socio-economic factors (desire to buy small and local, know your farmer); cultural shifts (remote work); geographical location (75 minutes from 3 metro areas); land conformation and use (smaller mixed use farmland), and nearby recreational and natural resources, it might be a good time to actively promote economic development of alternative agriculture production systems in Pine County.

- People looking to move out of metro for various reasons or relocating because they can work remotely in the new environment
- Homegrown PC folks looking to be a small farm entrepreneur
- People looking at career transition due to job changes during Covid-19
- Increasing trends in growing, promoting, processing local sustainable food
- Our affordable and diverse land base that lends itself to new farmers who have diverse interests and limited funds (Many in my Start-up class have as much interest in the environment, conservation, wildlife and the outdoors in general as they do in farming) They are not mutually exclusive.

Benefits of Pine County: Pine County can promote the reasons for why entrepreneurs should 'Produce it in Pine' or 'Plant it in Pine' or 'Plant yourself and your plants in Pine County'

- **Location** - Pine City is ~75 minutes from Twin Cities, St Cloud and Duluth. Parts of the county are much closer to these individual concentrated markets.
- **Specialized Start-up School:** There has been lots of interest in the Small Farm Start-up School but limited enrollment from Pine County (One current family and one family looking to relocate here.) We could discount the cost of the class for those planning to farm in Pine and offer modules specifically on farming in Pine County.
- **Land Use Diversity:** Land composition meets needs for livestock, row crops, specialty crops including forestry-based businesses.
- **Recreational Access:** Local access to lakes, forests, rivers, casino etc.
- **Affordable cost of living:** Land, housing and living expenses are lower.

Promotion Plan:

Funding: We could use funds from the class to support promotion and outreach. (We have ~\$2000 from this year's class revenues.) I intend to raise the price for the class starting in March 2021 and we could expand the size to 20 from 15. We could offer a \$50 credit for the class to those located in Pine County or actively considering locating in Pine County.

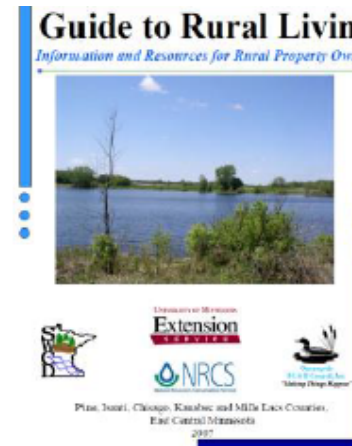

Guide to Rural Living Update (2007-2020)

Great resource that provides 99% of information needed by rural land owners in East Central MN. We will be updating the links, contact info and regs/statutes etc. and reformatting. This will be regional effort.



Beginning Farmer??

Thank you!

Questions?



Agriculture Economic Development Plan 2021-2023 (DRAFT)

Objective: Promote Pine County as a viable destination for establishment of small farms, market gardens, agritourism and other food-based on-farm businesses.

Working assumptions: For reasons that include: a number of socio-economic factors (desire to buy small and local, know your farmer); cultural shifts (remote work); geographical location (75 minutes from 3 metro areas); land conformation and use (smaller mixed use farmland), and nearby recreational and natural resources, it might be a good time to actively promote economic development of agriculture production systems in Pine County.

- People looking to move out of metro for various reasons or relocating because they can work remotely in the new environment
- Homegrown PC folks looking to be a small farm entrepreneur
- People looking at career transition due to job changes during Covid-19
- Increasing trends in growing, promoting, processing local sustainable food
- Our affordable and diverse land base that lends itself to new farmers who have diverse interests and limited funds (Many in my Start-up class have as much interest in the environment, conservation, wildlife and the outdoors in general as they do in farming) They are not mutually exclusive.

Benefits of Pine County: Pine County can promote the reasons for why entrepreneurs should 'Produce it in Pine' or 'Plant it in Pine' or 'Plant yourself and your plants in Pine County'

- **Location** - Pine City is ~75 minutes from Twin Cities, St Cloud and Duluth. Parts of the county are much closer to these individual concentrated markets.
- **Specialized Start-up School:** There has been lots of interest in the Small Farm Start-up School but limited enrollment from Pine County (One current family and one family looking to relocate here.) We could discount the cost of the class for those planning to farm in Pine and offer modules specifically on farming in Pine County.
- **Land Use Diversity:** Land composition meets needs for livestock, row crops, specialty crops including forestry-based businesses.
- **Recreational Access:** Local access to lakes, forests, rivers, casino etc.
- **Affordable cost of living:** Land, housing and living expenses are lower.

Promotion Plan:

Funding: We could use funds from the class to support promotion and outreach. (We have ~\$2000 from this year's class revenues.) I intend to raise the price for the class starting in March 2021 and we could expand the size to 20 from 15. We could offer a \$50 credit for the class to those located in Pine County or actively considering locating in Pine County.

Financial Assistance: Pine County 'could' offer a package of \$1000 plus 5 hours of Ext coaching ++ for establishment of a 'new' farm in the county (payable after Year 2)

Land clearinghouse: We could put together a clearinghouse for available land. We could match retiring farmers with new entrants. We could use lots of existing MDA and Extensions tools and programs to do this.

I just matched up a person with hayland to a person wanting to rent hay ground last week. I sold my farm to a Hmong family who wants to produce food for local markets.

Establish Pine County for a county-based pilot for UM Rural entrepreneurship initiative.

Operating Plan:

- We have the existing Small Farm Start-up School base we can build on for promotion.
- We have the Guide to Rural Living Resource Document that we can focus on Pine County etc.
- We can be a clearinghouse for financial assistance programs through USDA, MDA, non-profits
- ??
- Pine Extension can promote we are an access point to ALL of Extension's capabilities for agricultural production and marketing. While others can make some of these claims – Being first and loudest is a proven competitive advantage.
- Maybe develop a Small Food Incubator space on 5 acres? ~community garden on steroids....

Obstacles/Hurdles:

- What about funding for promotion and participant grants?
- What about infrastructure? meat processing plants, farmers markets, food hub, cool storage
- What about location? close but not close enough to major markets.
- What about sustainability of the trends? Remote work?
- What about quality of life etc.?
- And others.

Branding:

Middle of Everywhere!

Pining to Farm?

Plant it in Pine!

Plant yourself and your farm in Pine County.

A Pine Place to Farm

Footnotes:

- Have a regional focus ECMN but have Pine be the point of the spear
- Extension Priorities - Rural Entrepreneurship
- Mille Lacs Corporate Ventures – Small Business
- Katie Draper, Mille Lacs – Sustainable, Traditional Agriculture
- Initiative Foundation
- Thom Petersen, MDA
- Mike Sundeen MN Rep, Esko – House Ag Policy Chair, Pine, Carlton, St Louis
- Community Vitality-John Bennett, Bridget Tuck (Pine County data)
- NRCS/SWCD/FSA involvement
- MDA, emerging farmers programs
- MDA Grants <https://www.mda.state.mn.us/grants/agri>



- Pine County Page: https://www.co.pine.mn.us/departments/economic_development/index.php
- Pine County Economic Development
- https://www.co.pine.mn.us/departments/economic_development/clearinghouse_for_economic_development.php
- There's an old saying in marketing - 'It is better to be first than it is to be better.' While Pine might not match up to Stearns, Jackson or Pipestone or Meeker in land quality. We could succeed by being first and using the above resources and capitalizing on the above trends and points of differentiation..
- Another rule of marketing - "Difference creates competitive advantage." By having a unique message and positioning we can get attention and make others compare to us as the standard. Think of the 'Ely mock campaign' from several years ago.

Are any counties focused on actively recruiting on-farm businesses or operating farms?

DRAFT

Locations:

Pine County Courthouse, 635 Northridge Dr NW,
Pine City, MN 55063 and Isanti County
Government Center, 555 18th Ave SW, Cambridge
55008

Wednesday evenings-Oct 21-December 16.
6:30-8:30pm

(Many sessions will be delivered online)

WHAT PAST PARTICIPANTS ARE SAYING

“The panels and tours were great. I liked learning from the experts but hearing the farmer’s real-life experiences was eye-opening.”

“Well worth the time invested. Good people that have a passion for the material.”

“Invaluable. We’re inspired!”

“This class will help me avoid some expensive mistakes in the future.”

ABOUT SMALL FARMS PROGRAM

We understand the everyday heroics required to run a small farm. We can’t add more hours to the day, but we can make your day easier with practical, researched-based education.

Our programming efforts are aimed toward Minnesotans new to land ownership. Find more of our events and sign up for our email list at extension.umn.edu/smallfarms.

© 2020 Regents of the University of Minnesota. All rights reserved. University of Minnesota Extension is an equal opportunity educator and employer. In accordance with the Americans with Disabilities Act, this publication/material is available in alternative formats upon request. Direct requests to 612-624-0772 or afnr@umn.edu. ♻️ Printed on recycled and recyclable paper with at least 10 percent postconsumer waste material.

UNIVERSITY OF MINNESOTA | EXTENSION

University of Minnesota Extension
635 Northridge Drive NW
Pine City, MN 55063

Small Farm Education 2020 Workshop Series



**A COMPLETE INTRODUCTION TO
MANAGING YOUR SMALL ACREAGE
OR FARM**

Eight-week course runs:
October 21 – Dec 16

SMALL FARMS

UNIVERSITY OF MINNESOTA
EXTENSION



This workshop series will provide you with a solid background in all aspects of small farm operation and management. The basic agricultural information will help you be a good steward of your land and prepare you for more advanced learning opportunities.

The eight-week course, offered by University of Minnesota Extension, begins with goal setting and individual property inventory, then addresses soil, plant, livestock, equipment and water basics. You'll also have plenty of time for networking and questions.

For more information, please contact:

Rod Greder
Pine and Isanti County Extension
(320) 591-1662
gred0014@umn.edu

Pine City Pine County Extension Office
(320) 591-1650

Cambridge Isanti County Extension Office
(763) 689-8252

For more info online go to:
<https://z.umn.edu/SmallFarmInfo>

To register online please go to:
<https://z.umn.edu/SmallFarmRegistration>

Call (320) 591-1662 for details

THE FOLLOWING TOPICS WILL BE COVERED IN THIS EIGHT-WEEK PROGRAM (Subject to changes)

Taking Stock: What do I have and what do I want to do?? Develop short and long term goals, complete an inventory and property map. Introduction to Extension & our resources and programs.

What can I do with my property? Local & state regulations, and your goals. Production systems, marketing and economics for agricultural/rural enterprises. Farm transitions and land access.

Soil, Water, Air, Climate: Learn about soil structure, health, and fertility. Learn how to use integrated sustainable systems to be good stewards of all your natural resources. Regenerative and practical practices.

Buildings, Equipment, Crops, and Livestock: What do you want to produce? Learn about the buildings, equipment, power and supplies you'll need.

Woodlands and Wildlife: Information to best care for your trees and woodlots. Invasive weeds, pollinators and wildlife habitats. Agroforestry. Silvopasture.

Home-Gown Fruits, Nuts & Vegetables: Successful vegetable and fruit production for home use or sale. Managing fruit trees and vines. Explore options for selling produce. Alternative production systems. Food safety planning

Animal Care and Management: Animal husbandry; manure management; pasture management; zoning and permitting; Labor required and costs of livestock; Emphasis on poultry, sheep & goats, and cattle.

Tours and Panels: Visit small farm businesses to get ideas and inspiration. Q&A with farmer panel. Potential networking with suppliers, vendors, buyers, information providers.

NOTE: Topics are subject to change based on the needs of the participants. Some topics will be presented online.

**Small Farm Education
2020 REGISTRATION FORM**

REGISTRATION FEE:
\$159 for the course (covers two people from one farm) due Oct 10.

LATE FEE:
An additional \$20 will be charged for registrations after Oct 10.

Price includes the following:

- Registration for up to two people per farm
- Web access to all resources and course material
- Soil sample kits and instructions
- Farm tours/Farmer panels
- Networking with peers and experts
- Lots of great handouts & links
- Access to many experts
- All Information is evidence-based, unbiased

SCHEDULE OF EVENTS

All in-person and online synchronous classes are from 6:30 to 8:30 p.m. **Many sessions will be online.**

Pine County Courthouse, 635 Northridge Dr. NW, Pine City MN 55063 or Isanti County Government Center, 555 18th Ave SW, Cambridge 55008

ONLINE REGISTRATION:
<https://z.umn.edu/SmallFarmRegistration>

For registration assistance, please contact Pine County Extension Office, 320-591-1662.

NOTE: This course requires a minimum of eight registrants to proceed and may be cancelled due to low enrollment.

Visit the UMN Small Farms website for additional resources for beginning farmers:
www.extension.umn.edu/smallfarms

EXTENSION EDUCATOR UPDATE

Agriculture in Pine County

ROD GREDER

EXTENSION COMMITTEE REPORT NOVEMBER 19TH 2020

(Rod is in the Pine County Extension office on Tuesdays, 8am-3pm through December 31ST)

2020 Programs

- September 22nd - Pasture Management Field Day - 14 attendees
- October 21 - Small Farm Start-up School 15 families
- December 11 - Land Rent Workshop, Virtual and in-person



Social media/Website/Radio/Print:

Created Pine County Ag Extension FB page on March 24. **Currently have 160 followers.** Please like/follow/share!
<https://www.facebook.com/pine.county.extension>.

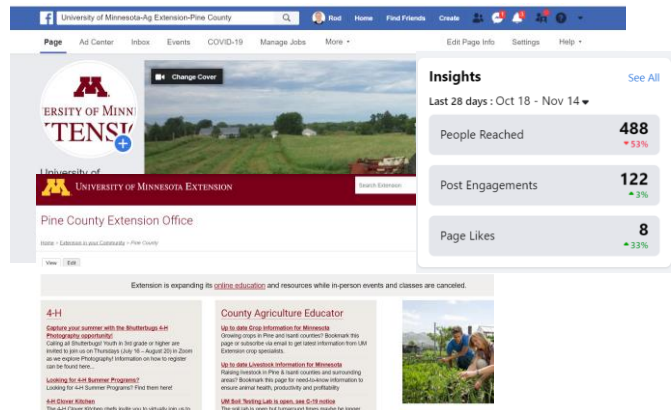

Created Pine County Ag page on local extension site with updates on crops and livestock.
<https://local.extension.umn.edu/local/pine-county/county-agriculture-educator>



Listen to the Pine County Extension Ag report on WCMP 100.9 at 5:30 on Friday, November 27th. We will discuss “winter feeding plans and harvest update” and other timely topics. <https://www.wcmpradio.com/> I am on **every other Friday.**

Guide to Rural Living Update (2007-2020)

Great resource that provides 99% of information needed by rural land owners in East Central MN. We will be updating the links, contact info and regs/statutes etc. and reformatting. This will be regional effort.

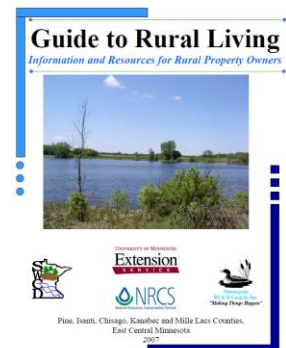

Small Farm Start-up School, Oct 21-Dec 16

Pine Ag Extension is offering a Small Farm Education series in Fall/Winter 2020. We have 15 farm families in the 5th week of the 8 week series. All content is delivered online via a Canvas self-paced course room and weekly live Zoom discussions. Farm tours and farmer Q&A panels are also included. All participants are required to write a business plan.

Class will be offered again in March, 2021. Five families are waitlisted.

For more information:

<https://local.extension.umn.edu/local/pine/county-agriculture-educator/article/small-farm-education-workshop-series>

UNIVERSITY OF MINNESOTA EXTENSION

2020 Small Farm Start-up School

Modules

- 🔗 ? Course Information and Help
- 🕒 (Online) Week 1 - Taking Stock-Planning & Setting Goals - Oct 21
- 🗓️ Farm Tours - October 24
- 🏠 (Online) Week 2 - What Can I Do with My Property?-Oct 28
- 💧 (Online) Week 3 - Soil, Water, Air, Climate-Nov 4
- 🏡 (Online) Week 4 - Buildings/Equipment/Crops-Nov 11
- 🌲 (Online) Week 5 - Woods, Wetlands and Wildlife-November 18
- 📰 Breaking News Archive



AG TECHNICAL ASSISTANCE (20 calls since August)

Example Topics: Covid-19 assistance (3), Land use, Soil-testing, Hayfield renovation, Fly control, Liver flukes, winter feeding plans, start-up school (10), pasture management

COLLABORATION WITH OTHER AGENCIES-GRANTS ETC.

- Working with SFA, NRCS to develop and test a mobile cart to support rotational grazing moves through SARE Research grant (~\$23,000).
- Working with NRCS/SWCD on promoting use of food plot equipment and no-till drill. Answering technical Q's.



AG EXTENSION GUIDING PRINCIPLES-2020

- Offer technical assistance and educational programming to Pine County farmers, ranchers and others to meet information needs to improve productivity, profitability, and sustainability of Agriculture.
- Assist with awareness and understanding of policies and regulations that affect producers. Hold meetings periodically on environmental, legal, financial topics.
- Support small farms: initiation, financing and growth by providing technical assistance, farm management software





training, technical programming, marketing strategies etc.

- Expose producers to alternative crops and livestock and new markets and help identify diversification opportunities.
- Support economic development and quality of life by assisting producers and local communities by developing, assessing and helping implement innovative value-added products and services.

QUESTIONS/CONTACT INFORMATION - Rod Greder, Ag Extension Educator gred0014@umn.edu, 320-591-1662(Office), 763-443-1531(Cell/Text), <https://local.extension.umn.edu/local/pine>, <https://www.facebook.com/pine.county.extension>

EXTENSION EDUCATOR UPDATE

Agriculture in Pine County

ROD GREDER

EXTENSION COMMITTEE REPORT JULY 16TH 2020

(Rod is in the Pine County Extension office on Tuesdays, 8am-3pm through August 31st)

See highlights below for UM Extension Agriculture Educator.

Working on updating and merging ag producer databases, introducing myself to stakeholders, creating online presence, answering technical enquiries, brainstorming training opportunities with collaborators, contacting local papers and radio to schedule columns and radio spots.

2020 Workshop Planning (tentative due to C-19)

- August/September – Pasture Management Field Days/Webinars
- October – Beginning Farmer series (see below)
- December – Land Rental Rates Update Meeting-Rock Creek

Social media/Website/Radio/Print:

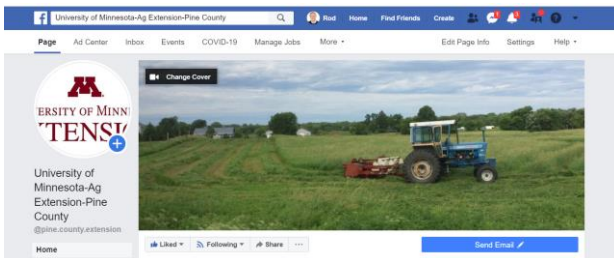

Created Pine County Ag Extension FB page on March 24. **Currently have 104 followers.** Please like/follow/share!

<https://www.facebook.com/pine.county.extension>

Created Pine County Ag page on local extension site with updates on crops and livestock.

<https://local.extension.umn.edu/local/pine-county/county-agriculture-educator>

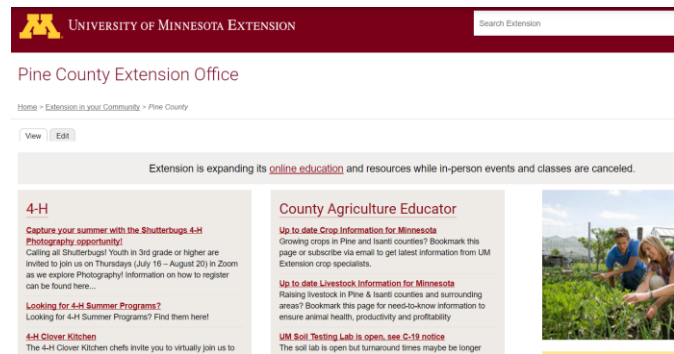

Listen to the Pine County Extension Ag report on WCMP 100.9 at 5:45 this Friday, July 17th. We discuss our dry conditions, weed control, pasture management and other timely topics. <https://www.wcmpradio.com/> I am on **every other Friday.**

Series for Beginning Farmers

Pine County Ag Extension is offering a Farmer Education series in Fall/Winter 2020/21. We've created an online learning component for the course that should expand the reach and demand for the training. (3-4 sessions will be online so no travel is required.) Curriculum is being revised and updated this summer. We will hold an information day on August 11th 6:30pm Location TBD. **Press release will be in local papers next week.**

See the DRAFT tri-fold brochure for more details.

AG TECHNICAL ASSISTANCE (13 ENQUIRIES HANDLED BY LEE since April 24th)

Example Topics: Soil-testing, Blackberry control, Sandhill Crane control in Corn Field, Green flies in Norway Pies, Buying land near Sturgeon Lake, Treating young calves for flies, Blackhead in turkeys/chickens, Spread of buttercup in horse pasture, ID Click Beetles, Insect damage on basswood trees, Reseeding hayfield

COLLABORATION WITH OTHER AGENCIES-GRANTS ETC.

- Working with SFA, NRCS to develop and test a mobile cart to support rotational grazing moves through SARE Research grant (~\$23,000).
- Working with SWCD on promoting use of food plot equipment and no-till drill. Answering technical Q's.



AG EXTENSION GUIDING PRINCIPLES-2020

- Offer technical assistance and educational programming to Pine County farmers, ranchers and others to meet information needs to improve productivity, profitability, and sustainability of Agriculture.
- Assist with awareness and understanding of policies and regulations that affect producers. Hold meetings periodically on environmental, legal, financial topics.
- Support small farms: initiation, financing and growth by providing technical assistance, farm management software training, technical programming, marketing strategies etc.
- Expose producers to alternative crops and livestock and new markets and help identify diversification opportunities.
- Support economic development and quality of life by assisting producers and local communities by developing, assessing and helping implement innovative value-added products and services.

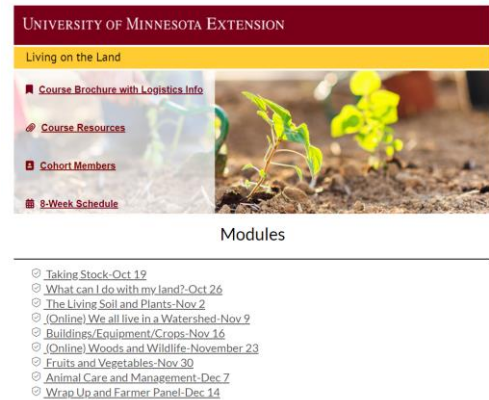

QUESTIONS/CONTACT INFORMATION - Rod Greder, Ag Extension Educator gred0014@umn.edu, 320-591-1662(Office), 763-443-1531(Cell/Text), <https://local.extension.umn.edu/local/pine>, <https://www.facebook.com/pine.county.extension>



AGENDA REQUEST FORM

Date of Meeting: January 5, 2021

- County Board**
 - Consent Agenda
 - Regular Agenda 5 mins. ___ 10 mins. ___ 15 mins. ___ Other ___
- Personnel Committee**
- Other** _____

Agenda Item: Property Clean-up Special Assessment

Department: Auditor-Treasurer

Kelly M. Shea
Department Head signature

Background information on Item:

The Pine County Planning and Zoning office was contacted by the new owner of a property in Pokegama Township off Brook Park Rd which was in a severe blighted condition (see attached photos). The property owner wanted to clean-up the property; however, the cost was difficult to front (\$28,500).

Given the homeowner's willingness to clean-up the property without any legal action, the property owner and the Zoning office devised a clean-up plan which was executed in November by Jones Construction. The property is now free from all junk materials, debris, vehicles, dilapidated, and unlivable buildings.

Action Requested:

Consider authorizing the County Board Chair and County Administrator to sign Resolution 2021-02 extending a special assessment on Pine County Parcel Number 28.0520.005 for \$28,500 for a term of 20 years at 0% interest.

Financial Impact:

The cost of the clean-up was paid from the 2020 Zoning Budget and will be reimbursed through the special assessment.

Property Clean-Up – 23550 Brook Park Rd, Brook Park

2018 Assessor Photos of the Property



2018 Aerial Photo of the Property - .9 acres needed to be cleaned up



**PINE COUNTY RESOLUTION EXTENDING
PROPERTY CLEAN-UP SPECIAL ASSESSMENT
RESOLUTION No. 2021-02**

WHEREAS, the Pine County Board of Commissioners recognizes the public health and environmental benefits of cleaning up severely blighted properties in the county;

WHEREAS, Pine County Planning & Zoning was contacted by the new owner, Marcus Ammerman, of the property legally described as:

That part of the Northwest Quarter of the Northwest Quarter lying south of the North 822 feet thereof in Section 2, Township 39, Range 22, Pine County Minnesota. Subject to County Highway 13 on the west side thereof.

WHEREAS, Pine County Planning & Zoning worked with the property owner to secure a contractor to clean-up the property and the property owner agreed to the terms of the special assessment for their already cleaned up property; and,

NOW THEREFORE BE IT RESOLVED, that the County of Pine extends a special assessment for a term of 20 years, beginning in 2022, against Pine County Parcel 28.0520.005 in the amount of \$28,500 with equal principal payments and 0% interest.

Dated this 5th day in January, 2021.

Chair
Pine County Board of Commissioners

ATTEST:

David J. Minke
County Administrator

Arrowhead Counties Association
Proposed 2021 Legislative Priorities
11/18/2020 DRAFT

- Protect CPA and PILT from reduced funding
- Promote a sustainable approach to Payment in Lieu of Taxes (PILT) that includes proposals to address instability in PILT payments for acquired lands
- Remove the county share of mistakenly billed federal IMD payments
- Address expenses counties incur for the clean-up and maintenance of blighted or environmentally contaminated tax forfeiture properties
- Increase funding for Community Corrections Act
- Protect county funding received as a result of the Moose Lake Regional Treatment Center closure in 1993
- Legislative authorization for the creation of carbon & wetland credits on Tax Forfeited Land
- Bonding funding – discuss/identify in January 2021



AGENDA REQUEST FORM

Date of Meeting: January 5, 2021

- County Board**
 - Consent Agenda
 - Regular Agenda 5 mins. ___ 10 mins. ___ 15 mins. ___ Other ___
- Personnel Committee**
- Other** _____

Agenda Item: Legal Publication

Department: Administration

Department Head signature

Background information on Item:

On December 29, 2020 a sealed bid for the cost of publication of the financial statement (first and second publication), County Board proceedings and other published notices as required by law was opened. The results were as follows:

The county received one bid for each the first publication and (if required) for the second publication as follows.

- A. **Pine City Pioneer:** \$8.75 per column inch for the first publication.
- B. **Pine County Courier:** \$8.75 per column inch to publish the second publication of the county financial statement.

These publication rates are the same as 2020.

Action Requested:

Award the 2021 bid for publication as shown above.

RECEIVED
DEC 14 2020

NorthStar

Printers • Publishers

NorthStar Media, Inc. • 930 S. Cleveland • 763-689-1181 • FAX 763-689-1185

December 8, 2020

David J. Minke, Pine County Administrator
Pine County Administrator's Office
635 Northridge Driver NW, Suite 200
Pine City, MN 55063

Dear Mr Minke,

Pursuant to the 1936 Supreme Court ruling involving the Brainerd Daily Dispatch, and based on an arrangement of all the newspapers of Pine County to provide an efficient, low-cost way to provide countywide circulation of County Board proceedings, the *Pine City Pioneer* submits the following bid for 2021:

To publish the proceedings of the County Board, the delinquent tax listings, the first publication of the financial statement, and such notices as are required by law, the rate will be \$8.75 an inch with a 7 point type and 9 lines per inch, the same rate as 2020. The second publication of the financial statement will be in the *Pine County Courier*. As in past years, all notices will go in all four Pine County newspapers. The first run of delinquent taxes will go in the *Pine City Pioneer* but the second run goes in all papers. The financial statements will run in the *Pioneer* and *Courier* papers only.

We would prefer legal notices emailed to publicnotices@pinecitymn.com. Our deadline is 3 p.m. on Mondays for Thursday publication.

Sincerely,



Jeff Andres
Group Publisher
Pine City Pioneer
Northstar Media, Inc.



AGENDA REQUEST FORM

Date of Meeting: 1/5/2021

- County Board**
 - Consent Agenda
 - Regular Agenda 5 mins. ___ 10 mins. ___ 15 mins. ___ Other ___
- Personnel Committee**
- Other** _____

Agenda Item: Labor Negotiations Update

Department: Administration

Department Head signature

Background information on Item:

The county has reached a tentative agreement with the remaining two bargaining units—Social Services Supervisors and Deputy Sheriffs.

The Social Services Supervisors have voted to approve the final proposal and the Deputies are scheduled to complete their voting on Monday, January 4th.

Both agreements are in line with the direction/parameters previously outlined by the county board.

1. Duration—3 years
2. Wages—Both agreements provide a 1.45% increase on January 1, 2021 and a 1.25% increase on July 1, 2021 and a 2% increase on January 1, 2022 and 2023. The deputies agree to a performance maximum of up to 2% which can be achieved after 15 years. The deputy uniform allowance increases \$25 for 2021 and an additional \$25 for 2022.
3. Insurance: Insurance contribution amounts are the same as other groups. The deputies have their insurance through the Teamsters Health & Welfare Fund.

Action Requested:

Consider approval of the Labor agreements with the Social Services Supervisors and Deputy Sheriffs.



AGENDA REQUEST FORM

Date of Meeting: January 5, 2021

- County Board**
 - Consent Agenda
 - Regular Agenda 5 mins.____ 10 mins.____ 15 mins.____ Other ____
- Personnel Committee**
- Other** _____

Agenda Item: Pandemic Business Relief Program

Department: Administration

Department Head signature

Background information on Item:

At the 7th Special Legislative Session on December 14, the state legislature passed a pandemic relief bill that was signed into law by Governor Walz. The legislation provides three buckets of funding.

1. \$88 million for businesses (bars, restaurants, bowling alleys, fitness centers) that have experienced a 30% or greater decline. This aid will be sent automatically by the state to the eligible businesses.
2. \$14 million for movie theaters and multipurpose convention centers. This aid will be managed by the state.
3. \$114.8 million for counties to make grants to eligible business and non-profits. The distribution is based on a per capita amount and Pine County will receive \$568,498.97.

The legislation directs that “Counties shall use the funds to make grants to individual businesses and nonprofits. . .”

At a minimum, recipients must be impacted by an Executive Order related to the COVID-19 pandemic and must use the funds for operations expenses incurred during the pandemic.

Counties have wide latitude to establish specific guidelines. Attached is a DRAFT program guideline.

The draft guideline establishes eligibility, provides a priority ranking system, and then determines the funding amount based on employees. The priority, grant amount, and tie to employee count is within the county’s discretion. In other words, the county could establish other criteria and grant amounts. We are planning to continue to work with the Initiative Foundation to administer the grants. The program provides 2.5% for administration expenses. This would provide the fee for the Initiative Foundation.

Grants must be award by March 15 and all funds expended by April 1. Unexpended funds must be returned to the state.

Action Requested:

Review the draft grant guidelines and provide direction.

DRAFT

Pine County Business and Non-Profit Assistance Grant Program

This program is funded by legislation approved in the 2020 7th Special Legislative Session. The program provides \$568,498.97 to Pine County to use to provide financial assistance to businesses and non-profits impacted by the pandemic.

Eligibility Requirements

- Applicants must be a business or non-profit with a physical establishment in Pine County. If there is a parent organization/company or a second location outside of Pine County, only the entity located in Pine County can apply to receive a grant.
- Eligible nonprofits include 501(c)(3) and 501(c)(19) veteran's organizations.
- Applicants must be able to document a financial hardship as a result of the COVID-19 pandemic.
- Applicants must be in good standing with the Minnesota Secretary of State with no outstanding tax liens filed against the applicant.
- Applicants must be in good standing with local ordinances.
- If applicable, hold a valid business license.
- Organizations must have generated at least \$10,000 in revenue in 2019 or 2020.
- Applicants must disclose all pandemic relief received including grants from federal, state or local sources and indicate any grant(s) applied for which are pending at the time of application.
- Applicants must certify in good faith that all documentation submitted is accurate and that any misrepresentations or fraudulent information will require repayment of grant funds.
- Home-based businesses are eligible and are defined as businesses where the primary office is registered and located at the owner's residence/property.
- Sole proprietorship and freelance workers such as musicians and artists, who reside or maintain a workplace in Pine County, are eligible to apply.
- Property management companies/landlords are eligible to apply. If a grant is used to compensate for unpaid rent, the landlord must agree to forego collection of unpaid rent to the extent it is covered by the grant.

Ineligible Businesses or Nonprofits

- Businesses/nonprofits that primarily derive income from gambling or adult entertainment.
- Agriculture, crop and livestock operations.
- Corporate chains and multi-state chains.
- Professional services firms such as insurance sales, law, bookkeeping/accounting services, financial advisors, etc.

Funding Priority

1st priority: Businesses/nonprofits which experienced a 25% or greater reduction in gross revenue as measured by any 3-month period March 1, 2020-present vs. any 3-month period during the 12 months prior to March 1, 2020.

2nd priority: Businesses which experienced a reduction in gross revenue less than 25% as measured by any 3-month period March 1, 2020-present vs. any 3-month period during the 12 months prior to March 1, 2020.

3rd priority: Businesses which have not received any pandemic relief previously including federal, state, or local sources.

4th priority: All remaining businesses.

Grant Amounts:

Grant amounts are based on the number of employees as of February 1, 2020. Any business not in existence on February 1 should use the number of employees at opening.

Maximum amounts:

- No W-2 employees up to \$10,000
- 1-10 FTE up to \$15,000
- 11-25 FTE up to \$20,000
- 26-100 FTE up to \$25,000
- 101 or more FTE up to \$30,000

The grant payments are considered taxable income.

Eligible Expenses Examples

- Mortgage or rental payments for business's place of operation.
- Expenses for communication or enforcement of public health orders such as signage and markings for social distancing measures.
- Utility Payments – electric, gas, sewer, water, trash removal – for the business's place of operation.
- Personal Protective Equipment (PPE) for employees or customer use, including sanitizing products, masks, face shields, gloves, etc.
- Vehicle and equipment lease or rental payments for items rented that were unable to be used due to business interruption or new leases that were incurred in order to facilitate change in business.
- Costs of perishable inventory disposal (those that have a limited shelf life) due to impacts from Emergency Orders.
- Property/casualty and liability insurance.

Ineligible Expense Examples

- Property tax payments
- Expenses unrelated to the business operation or non-profit primary mission
- Personal expenses
- Durable or hard-goods inventory replacement
- Start-up costs

Grants received from all sources must not exceed the amount of eligible expenses.

The information outlined above is a general guide. Final grant decisions will be made by the application review panel in consultation with the County Administrator. The County reserves the right to amend any criteria for eligibility as needed to best address the impact of the current pandemic and meet the intent of the legislation.